

SAMSUNG

Technical Data Book

**System Air-conditioner Control
System Guide**



History

Version	Modify	Date	Etc.
Ver.1.0	Release "System Air-conditioner Control System Guide" TDB	16.11.04	
Ver. 1.1	Modify DMS 2.5 key function page (P:110)	17.03.23	
Ver.2.0	Release the first half of 2017 version.	17.08.31	
Ver.2.1	Released the SAC Control System Guide 2018 Version	18.02.28	
Ver.2.2	Released the second half of 2018 version	18.07.10	
Ver.2.3	Released the SAC Control System Guide 2019 Version	18.12.31	
Ver.2.4	Released the second half of 2019 Version	19.07.09	

Contents

Individual Control System

Wireless Remote Controller	10
AR-EH03U	
AR-KH03U	
Wired Remote Controller	21
MWR-WE13UN	
Simple Type	43
MWR-SH00UN	
Touch Simple Type	53
MWR-SH11UN	
ReceiverKIT	65
MRK-A10N	

Centralized Control System

OnOff controller	67
MCM-A202DUN	
Touch centralized controller	74
MCM-A300UN	
Wi-Fi kit	87
MIM-H03UN	
Module Controller	101
MCM-A00UN	

Integrated management System

DMS2.5	118
MIM-D01AUN	
S-NET3	170
MST-P3P	

Gateway

BACnet Gateway	187
MIM-B17BUN	
LonWorks Gateway	214
MIM-B18BUN	
External Contact Interface Module	233
MIM-B14	
PIM (Pulse Interface Module)	238
MIM-B16UN	
Interface module	250
MIM-N01	
FCU interface module	259
MIM-F10N	













Installation /Test run Solution

S-Converter	265
MIM-C02N	











Others

External Room Sensor	270
MRW-TA	
Operation mode selection switch	272
MCM-C200U	
MTFC (Multi Tenant Function Controller)	274
MCM-C210N	

Controller Line up & Compatibility Table

Classification	Product	Model Name	Product Image	Compatibility Table							
				DVM	CAC	DVM Chiller	Water FCU	FCU Kit	ERV Kit	UCK Kit	AHU Kit
Individual Control System	Wireless Remote Controller	AR-EH03U		O	O	X	O	O	X	O	O
	Wireless Remote Controller (360 Only)	AR-KH03U		O	O	X	O	X	X	X	X
	Wired Remote Controller	MWR-WE13UN		O	O	X	O	O	X	O	O
	Wired Remote Controller - Simple Type	MWR-SH00UN		O	O	X	O	O	X	X	X
	Wired Remote Controller - Touch Simple Type	MWR-SH11UN		O	O	X	O	O	X	X	X
	Receiver Kit (Duct Only)	MRK-A10N		O	O	X	X	X	X	X	X
Centralized Control System	Touch Centralized Controller	MCM-A300UN		O	O	O	O	O	O	O	O
	Onoff Controller	MCM-A202DUN		O	O	O	O	O	X	O	O
	Wi-Fi Kit	MIM-H03UN		O	O	X	O	X	O	O	O
	Module Controller	MCM-A00UN		X	X	O	X	X	X	X	X
Integrated management System	DMS2.5	MIM-D01AUN		O	O	O	O	O	O	O	O
	S-NET3	MST-P3P		O	O	X	X	X	X	O	O

Controller Line up & Compatibility Table

Classification	Product	Model Name	Product Image	Compatibility Table							
				DVM	CAC	DVM Chiller	Water FCU	FCU Kit	ERV Kit	UCK Kit	AHU Kit
Interface & Gateway	BACnet Gateway	MIM-B17BUN		O	O	O	O	O	O	O	O
	Lonworks Gateway	MIM-B18BUN		O	O	O	O	O	O	O	O
	PIM (Pulse Interface Module)	MIM-B16UN		O	O	O	O	O	O	O	O
	External Contact Interface Module	MIM-B14		O	O	O	O	O	X	O	O
	Interface Module	MIM-N01		O	O	X	X	X	X	O	O
	FCU Interface Module	MIM-F10N		X	X	X	O	O	X	X	X
Installation /Test run Solution	S-Converter	MIM-C02N		O	O	O	O	O	O	O	O
Others	External Room Sensor	MRW-TA		O	O	X	O	O	X	X	X
	Operation Mode Selection Switch	MCM-C200U		O	X	X	X	X	X	X	X
	MTFC (Multi Tenant Function Controller)	MCM-C210N		O	X	X	X	X	X	X	X

Overview of DVM S New communication system diagram

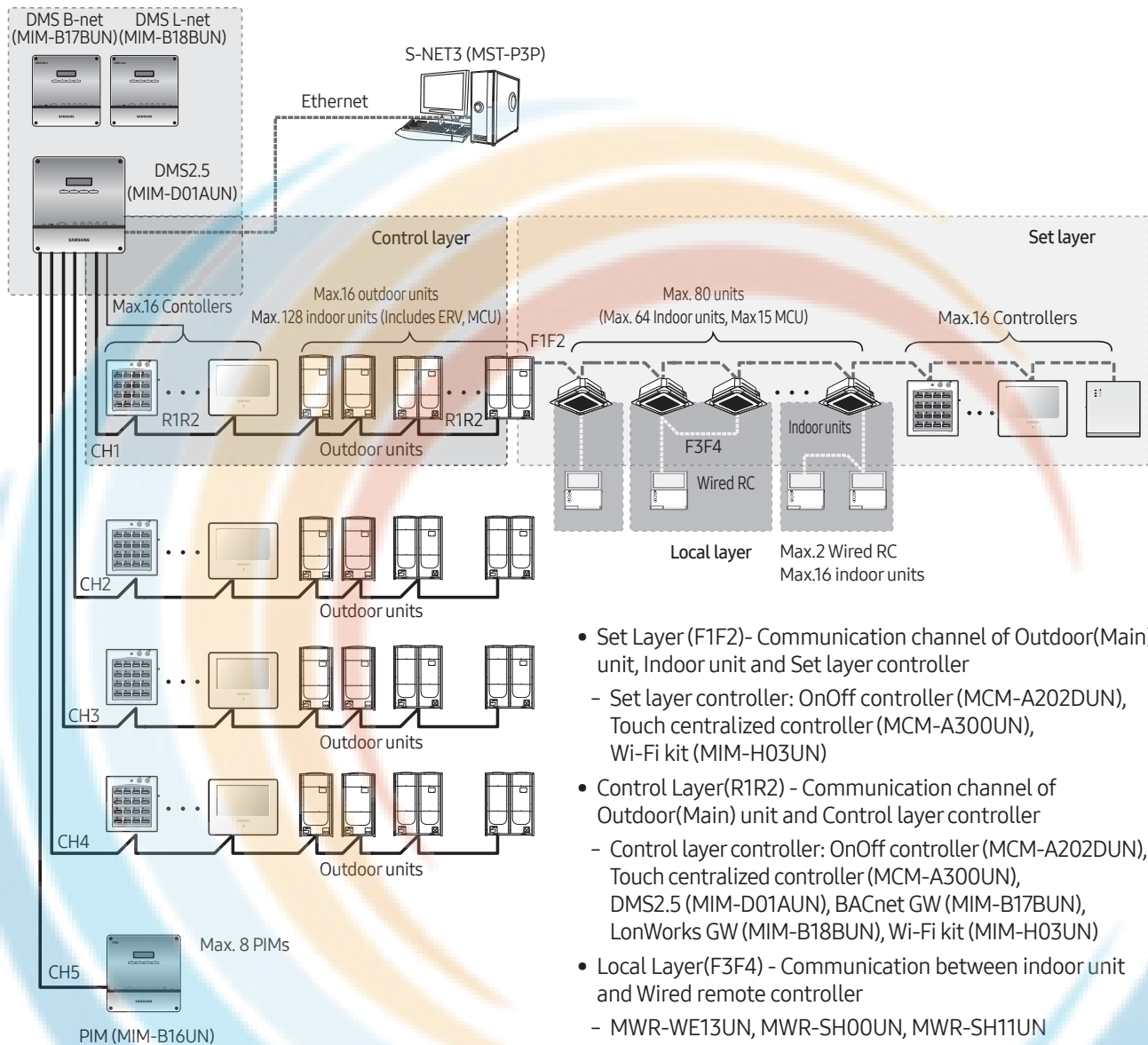

- Set Layer (F1F2)- Communication channel of Outdoor(Main) unit, Indoor unit and Set layer controller
 - Set layer controller: OnOff controller (MCM-A202DUN), Touch centralized controller (MCM-A300UN), Wi-Fi kit (MIM-H03UN)
- Control Layer(R1R2) - Communication channel of Outdoor(Main) unit and Control layer controller
 - Control layer controller: OnOff controller (MCM-A202DUN), Touch centralized controller (MCM-A300UN), DMS2.5 (MIM-D01AUN), BACnet GW (MIM-B17BUN), LonWorks GW (MIM-B18BUN), Wi-Fi kit (MIM-H03UN)
- Local Layer(F3F4) - Communication between indoor unit and Wired remote controller
 - MWR-WE13UN, MWR-SH00UN, MWR-SH11UN

• Case 1 > When DVM S is connected to conventional system

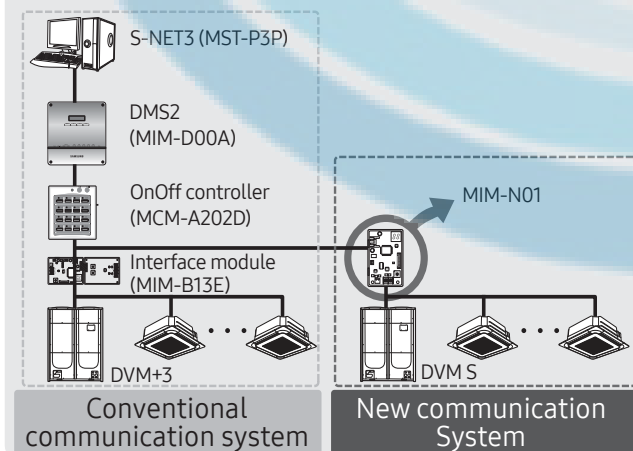

• Case 2 > When DVM+3 is connected to new system

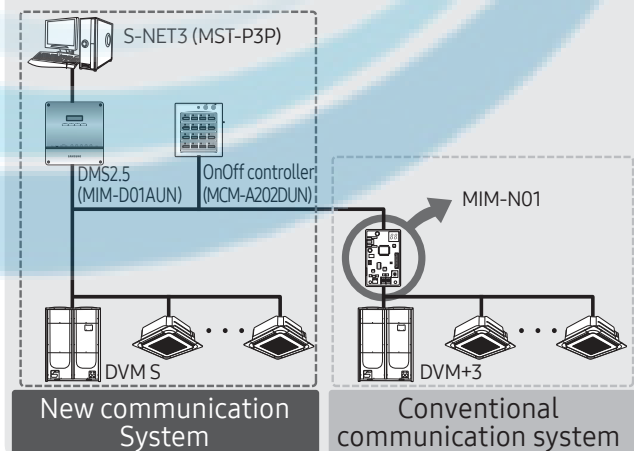

Chapter 01

Individual Control System

Wireless Remote Controller

AR-EH03U.....	10
AR-KH03U.....	16

Wired Remote Controller

MWR-WE13UN.....	21
-----------------	----

Simple Type

MWR-SH00UN.....	44
-----------------	----

Touch Simple Type

MWR-SH11UN.....	54
-----------------	----

Receiver KIT

MRK-A10N.....	65
---------------	----

Wireless Remote Controller

AR-EH03U

Features

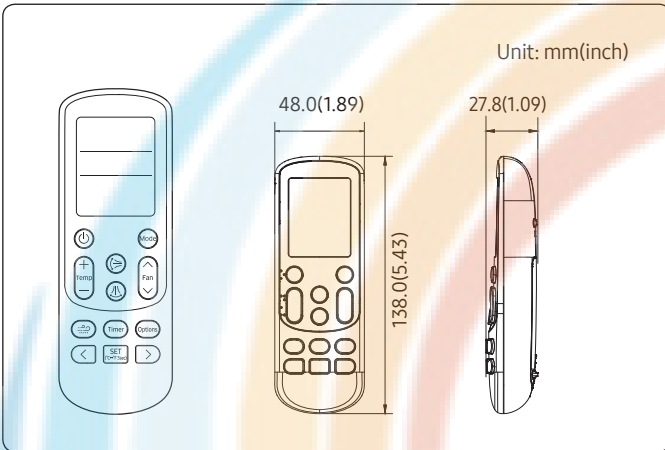

Easy and convenient operation control

- Operation ON/OFF control
- Fan speed control
- Operation temperature setting
- Filter replacement alarm reset
- Air swing control
- Simple ON/OFF timer
- Indoor unit option code setting
- Option/Setting selection

Mode	Auto/Cool/Dry	Heat
Operating Temperature Range	18°C(65°F)~30°C(86°F)	16°C(61°F)~30°C(86°F)

Description of parts

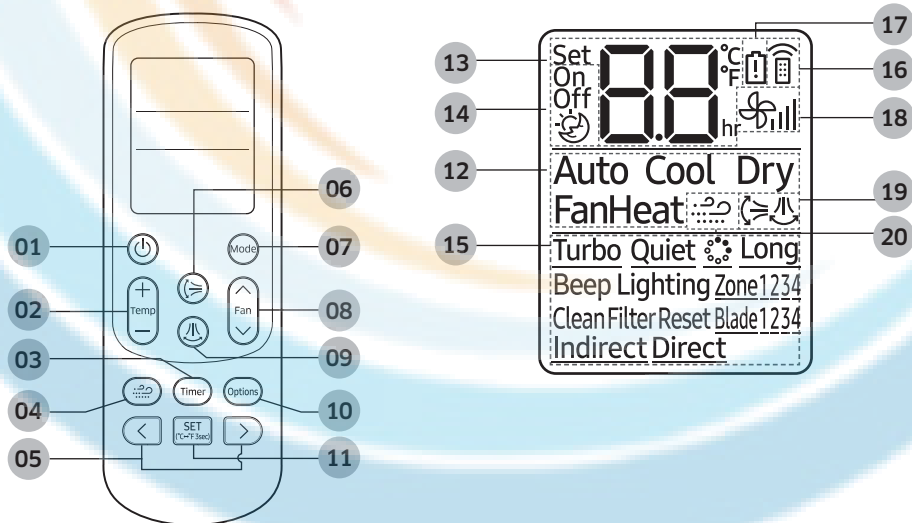

No	Name	Description
01	On/Off button	Press this button to turn On/Off the indoor unit.
02	Temperature button	Press this button to increase/decrease the set temperature by 1°C(1°F).

Wireless Remote Controller > AR-EH03U

No	Name	Description
03	Timer button	Sets timer option.
04	Wind-Free button	Sets Wind-Free mode.
05	Direction button	Moves to select and set an option.
06	Air flow direction (Up and down) button	Press this button to activate/deactivate vertical air flow movement. (Not applicable to Duct type model)
07	Operation mode button	Press this button to select one of the 5 operation modes. (Auto, Cool, Dry, Fan, Heat)
08	Fan speed button	Press this button to select one of the fan speeds. (Auto, Low, Medium and High.)
09	Air flow direction (Left and right) button	Press this button to activate/deactivate horizontal air flow movement.
10	Options button	Selects options during operation.
11	Set/Cancel button	Selects or cancels an option. And sets Temperature type (°C → °F)
12	Operation mode indicator	Indicates the operation mode.
13	Set temperature & On/Off set time indicator	<ul style="list-style-type: none"> • Basic – Indicates the set temperature. • Timer setting – Indicates the On/Off set time.
14	On/Off timer indicator	Indicates the On/Off timer setting.
15	Options indicator	Indicates the selected [Option] - Turbo, Quiet, SPI, Long, Filter reset, Beep, Blade selection
16	Transmission indicator	Indicates when wireless signal is received (by pressing any buttons).
17	Low battery indicator	Indicates the battery life.
18	Fan speed indicator	Indicates the fan speed settings.
19	Air swing indicator	Indicates when vertical or horizontal air flow movement.
20	Wind-Free indicator	Indicates the Wind-Free setting.

Wireless Remote Controller > AR-EH03U

Key operation function

Wind-Free Cooling function



Use the Wind-Free Cooling function to enjoy mild cool breeze exuding from fine holes on the Wind-Free panel with the air flow blade closed, instead of getting cool wind directly. The automated control of the temperature and fan speed according to the indoor temperatures keeps your room cool and pleasant.

In the Cool, Dry, or Fan mode ▶ 

Note

- To cancel this function, press the  button again.
- If the Wind-Free Cooling function is cancelled, the air conditioner returns to the original fan speed.
- You can adjust the set temperature during the Wind-Free Cooling function, and recommended set temperatures are 24 to 26 °C (75 to 79 °F). However, you cannot change the set temperature in the Fan mode.
- You can use the Wind-Free Cooling function when the Cool, Dry, or Fan mode is running.
- If the room temperature goes high because of rise of external temperature, heat from cooking, or other reason, operate the Wind-Free Cooling function after operating in the Cool mode.
- If you select the Wind-free Cooling function in the Fan mode, the compressor stops working so that cool air does not come out. However, mild breeze comes out and starts to clean the air in the room.
- During the Wind-Free Cooling operation, the cold air may be intermittently weakened depending on the temperature and humidity in the room. But the Wind-Free air currents are maintained and the weakened cold air is immediately recovered, consequently keeping the room comfortable. (During the Wind-Free Cooling operation, the air flow blades may open to control the indoor air currents smoothly, depending on the installation settings. In this case, as soon as the indoor temperature and humidity change, the air flow blades are closed and the Wind-Free Cooling operation restarts. For more information on the installation settings, see "Setting the indoor unit addresses and the installation options" in the installation manual of the indoor unit.)

Change of the air flow blade by temperature and humidity			
Indoor temperature and humidity	Low	High	
	Breeze is blown via the micro holes on the air flow blades	Breeze is blown via the micro holes on the air flow blades	Breeze comes from the air flow blade depending on the setting
Air flow blade	Closed	Closed (default)	Opened (according to setting)

- When the Wind-Free Cooling function runs while sleeping, you may feel cold air if the air conditioner is installed over the bed. In this case, set the desired temperature higher than the normal setting temperature.
- If you select the Wind-Free Cooling function while such functions as Turbo, Quiet, Long reach, an Air flow direction (, ) or good'sleep are running, these functions are cancelled.

Key operation function

Long reach function

Use the Long reach function to deliver strong air flow that quickly reaches a far distance.

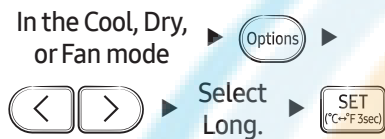

Note

- You cannot change the fan speed.
- If you select the Long reach function while such functions as Wind-Free Cooling, Turbo, Quiet or good'sleep are running, these functions are cancelled.

Clean function

Use the Clean function to remove moisture from the inside of the air conditioner for preventing propagation of fungi, bacteria, etc.



Note

- Depending on the condition of the indoor unit, the Clean operation stops after running for 30 seconds to 20 minutes.
- When the Clean function is set, the Timer LED on the indoor unit blinks 3 times for 3 seconds (OFF → ON → OFF → ON → OFF → ON → OFF → returns to the previous state). When the Clean function is cancelled, the Timer LED on the indoor unit blinks once for 1 second (OFF → ON → OFF → returns to the previous state).
- You cannot use the Clean function after starting the Timed Off or good'sleep function.
- If you turn on the air conditioner and then turn it off within 20 seconds, the Clean function does not operate.
- When the air conditioner is turned off, the Clean function operates immediately. When it is turned on, the Clean function operates after it is stopped.
- Once the Clean function is started, it automatically continues to operate until it is cancelled.

Wireless Remote Controller > AR-EH03U

Motion Detection Feature

Indirect function with Motion detection feature

Use the Indirect function to get an indirect wind so that you can feel comfortable. When this function is turned on, the air conditioner detects people and blows air indirectly around them.



Note

When the Indirect function is set simultaneously with the Auto, Dry, Fan, Wind-Free Cooling, Turbo, Quiet, Long reach, air flow direction (↘, ↙) or good'sleep function, **Indirect** is displayed on the remote control display but this function does not operate.

Direct function with the Motion detection feature

Use the Direct function to get a direct wind so that you can feel comfortable. When this function is turned on, the air conditioner detects people and blows air directly toward them.

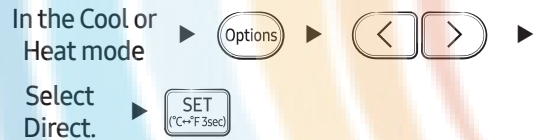

Note

- When the Direct function is set simultaneously with the Auto, Dry, Fan, Wind-Free Cooling, Turbo, Quiet, Long reach, air flow direction (↘, ↙) or good'sleep function, **Direct** is displayed on the remote control display but this function does not operate.
- The Direct function is not supported by MCR-SMA model.

To use the Motion detection feature, the air conditioner must be equipped with a Motion Detection Kit, which is sold separately. If the Motion Detection Kit is already installed, the motion detection feature must be enabled so that it can operate normally. (For more information, refer to the Motion Detection Kit manual.) When **Direct** or **Indirect** is displayed on the remote control display, the Motion detection feature changes the air conditioner to energy-saving mode if there are no people in the room.

Wireless Remote Controller > AR-EH03U

Additional function

Option code setting

- 1 Remove the batteries from the remote controller.
- 2 Press the Temp [+] and [-] button at the same time and insert the batteries.
- 3 Set the 2 digits of option code.
If you press the Fan [^] button, you can change the right digit.
If you press the Fan [v] button, you can change the left digit.
- 4 Press the [Mode] button to set the next 2 digits of option code.
Input 20 digits in total.
- 5 Press the [Power] button more than twice to set the indoor unit option code.
(When indoor unit option code is set, a beep will sound. When the setting is incorrect, all the LED on the indoor unit panel will flicker.)

Note

- Option code is composed with total of 24 digits including page number. From the wireless remote controller, enter the option code without page number.

Setting Ex.)

Option code: 012345 - 16789A - 212345 - 36789A

↑ ↑ ↑ ↑
 Page 0 Page 1 Page 2 Page 3

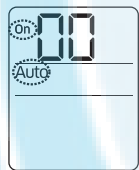

Option code input mode

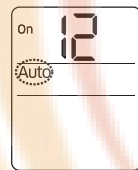

Fan [^]-Right digit
Fan [v]-Left digit

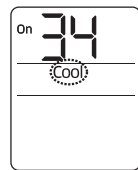

Press the [Mode] button to set the next 2 digits.

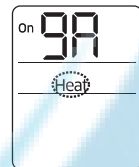
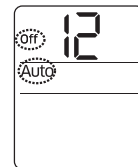
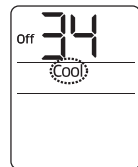
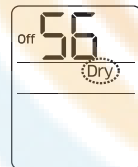
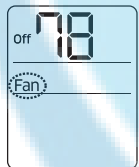
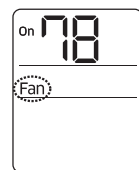
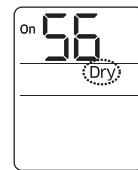

If you press the [Mode] button after entering first 10 digits, On timer indicator will change to Off.

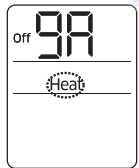

Press the [Power] button more than two times towards the indoor unit.

Wireless Remote Controller > AR-KH03U

AR-KH03U

Features

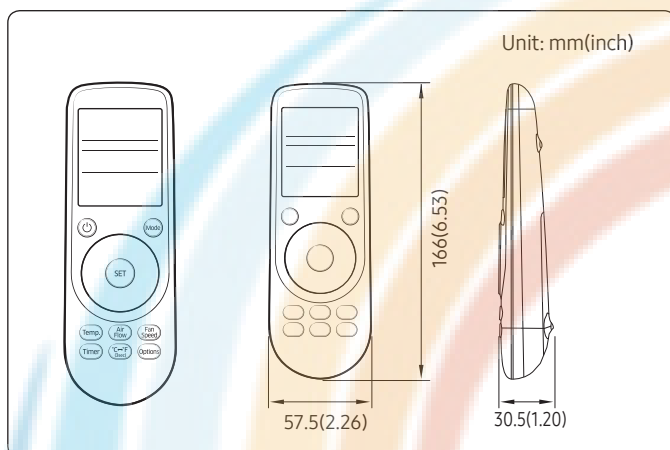

Easy controlling with the wheel

- 360 cassette air flow direction control
- Operation ON/OFF control
- Fan speed control
- Operation temperature setting
- Filter replacement alarm reset
- Simple ON/OFF timer
- Indoor unit option code setting

Description of parts

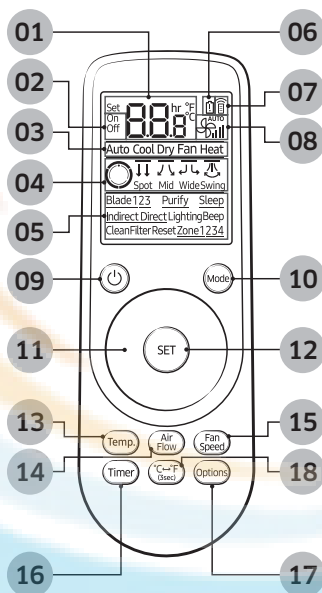

No	Name	Description
01	Set temperature/ Timer indicator	<ul style="list-style-type: none"> • Basic – Indicates the set temperature. • Timer setting – Indicates the ON/OFF set time.
02	Timer option indicator	Indicates the timer option
03	Operation mode indicator	Indicates the operation mode.
04	Air flow direction indicator	Indicates the air flow direction (Spot, mid, wide, swing)

Wireless Remote Controller > AR-KH03U

No	Name	Description
05	Options indicator	Indicates the option function setting. (Filter reset, Beep, Zone, etc)
06	Low battery indicator	Indicates the battery life.
07	Signal transmission indicator	Indicates when wireless signal is received. (by pressing any buttons)
08	Fan speed indicator	Indicates the fan speed setting.
09	Power button	Press the button to turn On/Off the indoor unit.
10	Mode button	Press the button to select operation mode. (Auto, Cool, Dry, Fan, Heat)
11	Wheel	You can control the set temperature, fan speed, and air flow direction by rotating the Wheel.
12	SET button	Press the button to confirm the selection.
13	Temperature button	If you press the button then the set temperature will be increased by 0.5°C(0.5°F)
14	Air flow direction button	Press the button to select air flow direction.
15	Fan speed button	Press the button to select fan speed.
16	Timer button	Press the button to set timer option.
17	Options button	Press the button to select option function.
18	Temperature type button (°C ↔ °F)	Press the button to change temperature type

Smart Features

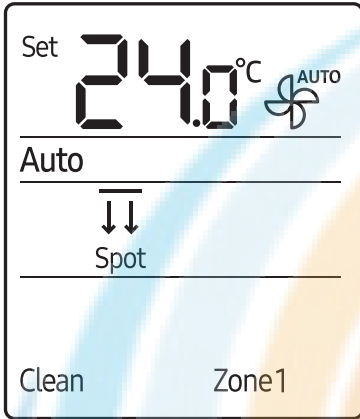

Clean function

Use the Clean function to remove moisture from the inside of the air conditioner for preventing propagation of fungi, bacteria, etc.

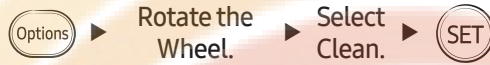

Note

- You can also select the function that you want to use by pressing the **Options** button repeatedly until it appears on the remote control display.
- Depending on the condition of the indoor unit, the Clean operation stops after running for 30 seconds to 20 minutes.

Air conditioner on/off status	When the Clean function is set	When the Clean function is cancelled.
When the air conditioner is on	<ul style="list-style-type: none"> • The Timer LED blinks 3 times. • The Clean function operates after the air conditioner is stopped. 	The Timer LED blinks once.
When the air conditioner is off	<ul style="list-style-type: none"> • The Timer LED blinks 3 times. • The Clean function operates immediately. 	

- You cannot use the Clean function after starting the Timed Off function.
- Each time you select the Clean button, the Clean function is alternately set and cancelled. (Be sure to check the Timer LED blinking status.)

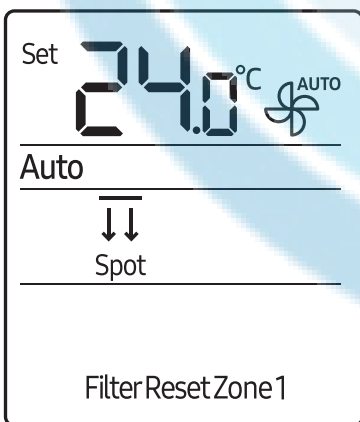

Clearing the filter-cleaning reminder

Use the Filter Reset function to reset the filter-cleaning reminder after cleaning or replacing the filter.

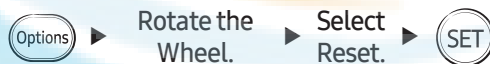

Note

- You can also select the function that you want to use by pressing the **Options** button repeatedly until it appears on the remote control display.
- When the Filter Reset function is run, **Filter Reset** appears on the remote control display for three seconds and then disappears.

Wireless Remote Controller > AR-KH03U

Motion Detection Feature

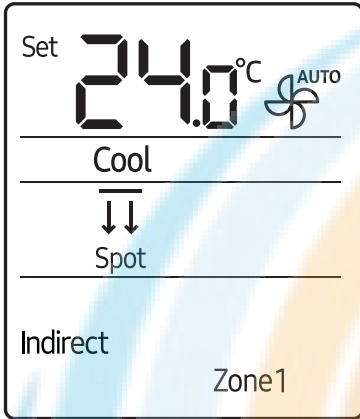

Indirect function with Motion detection feature

Use the Indirect function to get an indirect wind so that you can feel comfortable. When this function is turned on, the air conditioner detects people and blows air indirectly around them.

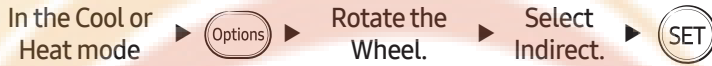

Note

- You can also select the function that you want to use by pressing the button repeatedly until it appears on the remote control display.
- When the Indirect function is set simultaneously with the Auto, Dry, or Fan mode, Indirect is displayed on the remote control display but this function does not operate.

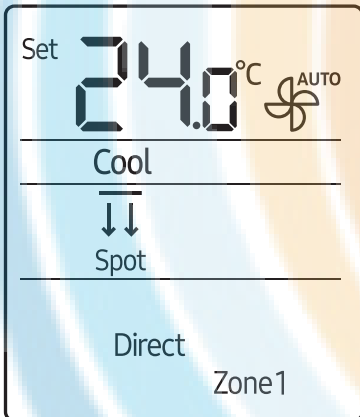

Direct function with the Motion detection feature

Use the Direct function to get a direct wind so that you can feel comfortable. When this function is turned on, the air conditioner detects people and blows air directly toward them.

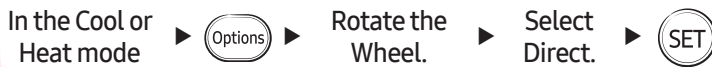

Note

- You can also select the function that you want to use by pressing the button repeatedly until it appears on the remote control display.
- When the Direct function is set simultaneously with the Auto, Dry, or Fan mode, Direct is displayed on the remote control display but this function does not operate.

Additional function

Option code setting

- 1 Remove the batteries from the remote control.
- 2 While holding down the and buttons simultaneously, insert the batteries into the remote control.
- 3 Set the 2 digits of option code
 - If you rotate the wheel counterclockwise, you can change the left digit.
 - If you rotate the wheel clockwise, you can change the right digit.
- 4 Press the button to set the next 2 digits of option code. Input 20 digits in total
- 5 Press the button more than twice to set the indoor unit option code.
(When indoor unit option code is set, a beep will sound. When the setting is incorrect, indoor unit will display error.)

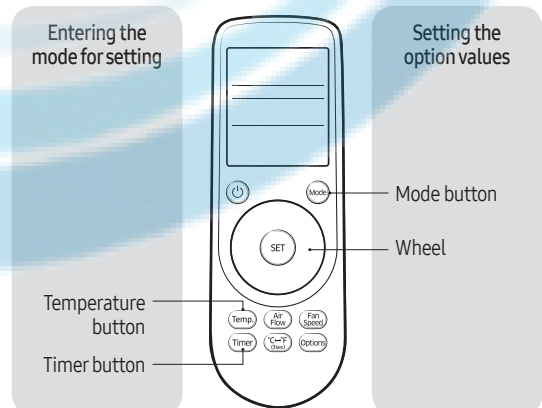

Wireless Remote Controller > AR-KH03U

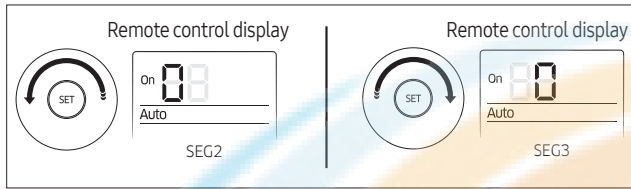

Note

- Option code is composed with total of 24 digits including page number. From the wireless remote controller, enter the option code without page number.

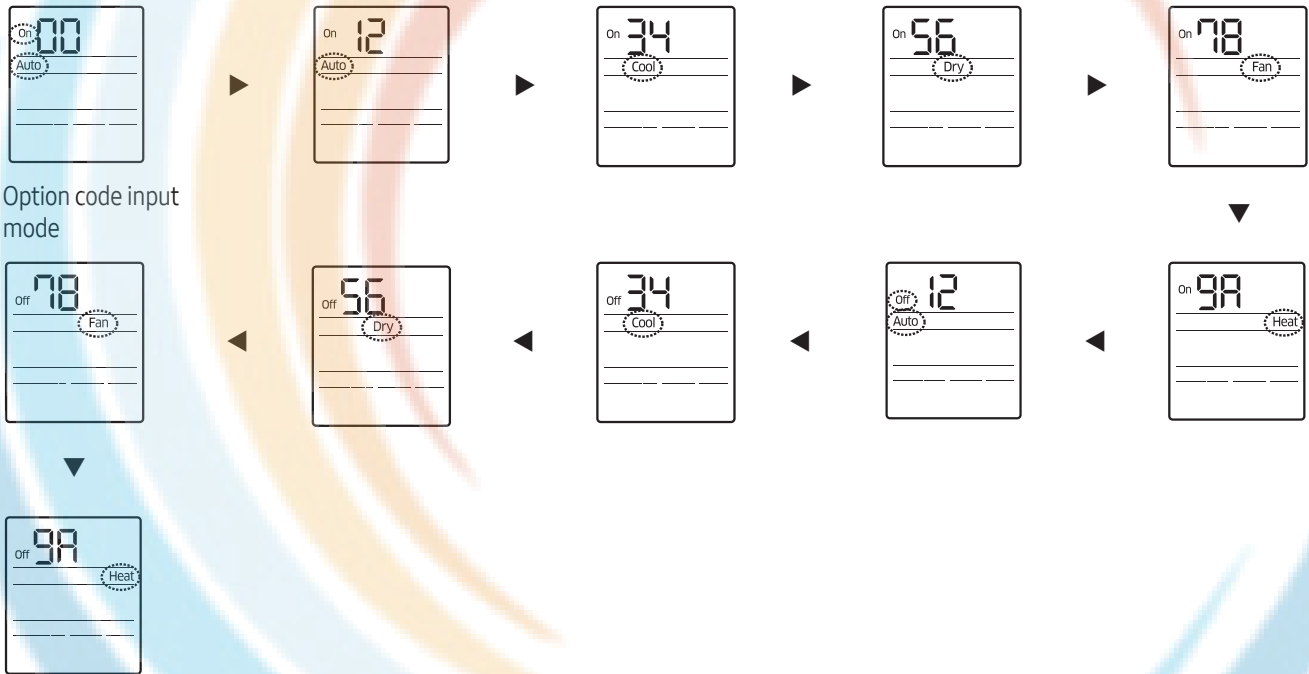

Wired Remote Controller

MWR-WE13UN

Features

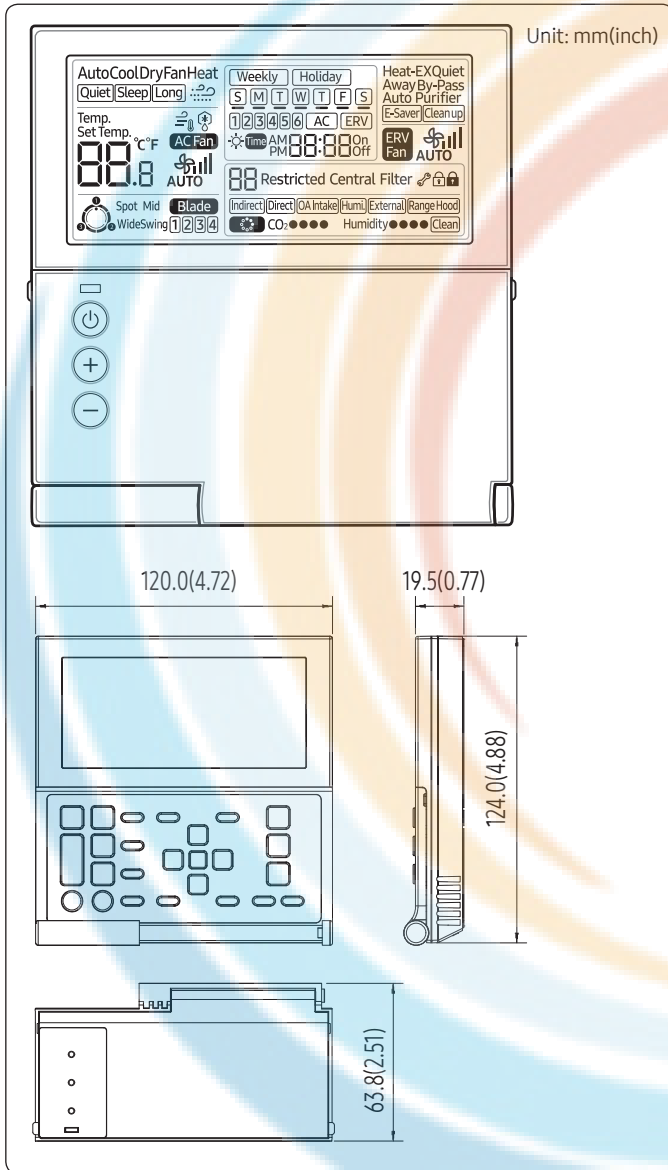

Air conditioner/ERV control

- AC operation ON/OFF control
- AC operation mode, setting temperature, fan speed, air flow direction setting
- AC individual blade control (Function is available when indoor units support any of above functions)
- ERV operation ON/OFF control
- ERV operation mode, fan speed setting
- AC/ERV error monitoring
- Filter cleaning alert and reset alert time
- Individual/group control, indoor unit/ERV interlocking control
- Energy saving control
- Control maximum 16 "Indoor unit + ERV" in group with single wired remote controller

Energy saving operation

- Upper/Lower temperature limit setting
- Automatic operation stop: Automatically stops the operation, when it is not used for certain period of time set by user

Weekly operation schedule setting

- Weekly operating schedule (A/C only, ERV only, A/C+ERV)
- Able to set desired AC operation mode, setting temperature and fan speed to operate based on weekly reservation
- Able to apply schedule exception day

User convenience function

- Child lock
- Different button permission levels (Operation mode, temperature setting, ON/OFF, fan speed)
- Real-time clock: Displays current time, day (Summer time support)
- Built-in room temperature sensor
- Service mode support
 - Indoor unit cycle data monitoring
 - Indoor unit option code setting and monitoring
 - Indoor unit address setting and monitoring

Wired Remote Controller > MWR-WE13UN

Product specification

Power Supply	Power Consumption	Operating Temperature range	Operating Humidity range	Communication
DC 12V	2W	0°C~40°C (32°F~104°F)	30%RH~90%RH	2-wire PLC

Compatible product







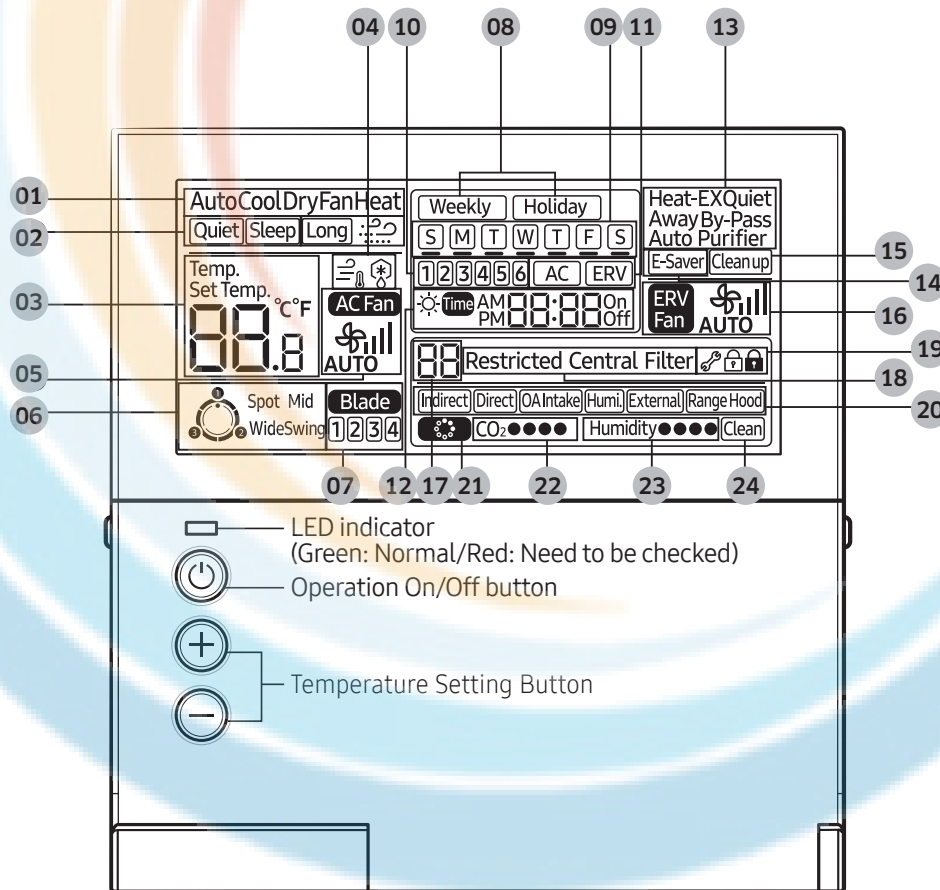











Indoor unit
AM****N*****Model

Description of parts

Display



Wired Remote Controller > MWR-WE13UN







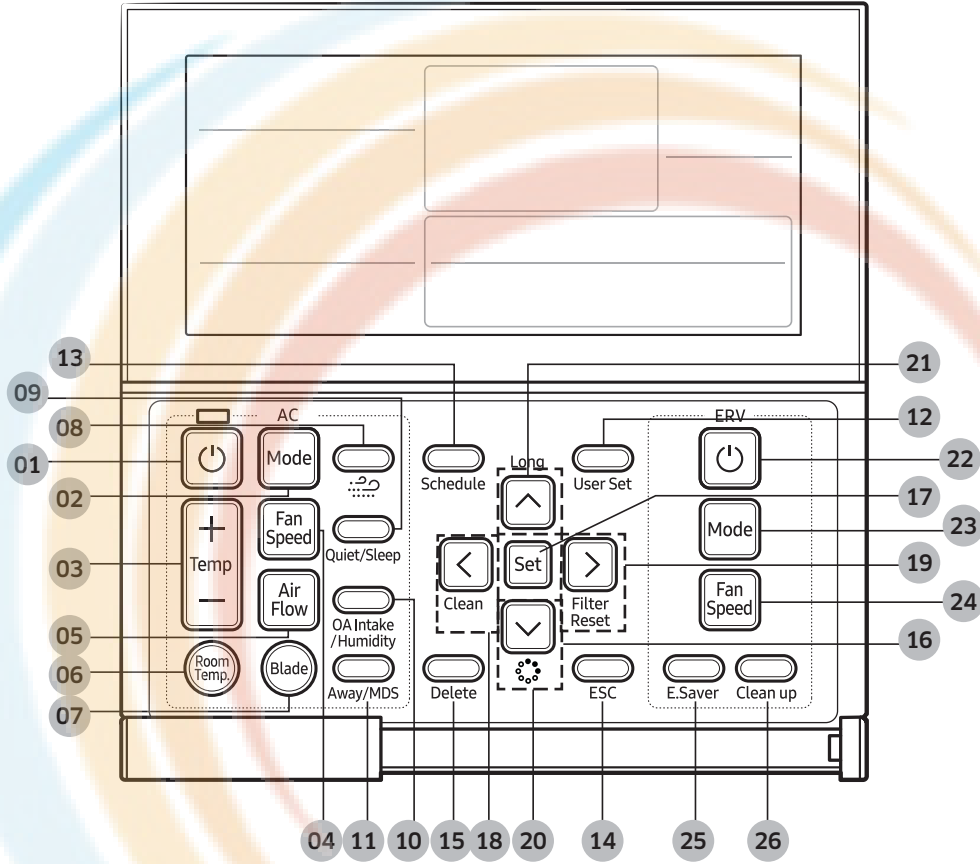





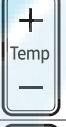







Classification	Indication	Function
Air Conditioner Related Information	01 AutoCoolDryFanHeat	Displays air conditioner operation
	02 	Displays Quiet/Sleep/Long/Wind-Free Cooling operation
	03 Temp. Set Temp. °C°F 	Displays indoor temperature/ set temperature
	04 	Displays discharge temperature control/defrosting operation
	05 AC Fan  AUTO	Displays AC fan speed
	06  Spot Mid WideSwing	Displays air flow directions
	07 Blade 	Displays blade selection
Schedule related information	08 Weekly Holiday	Weekly schedule/Holiday setting displays
	09 	Displays current day(□) or scheduled day(□)
	10 	Displays scheduled number
	11 AC ERV	Displays scheduled device selection
	12  time AM PM  On Off	Displays current time/summer time/scheduled time
	Ventilator (ERV) related information	13 Heat-EXQuiet Away By-Pass Auto Purifier
14 E-Saver		Displays Energy Saving Operation
15 Clean up		Displays Clean up
16 ERV Fan  AUTO		Displays ventilator (ERV) fan speed
Common function related information	17 	Displays remaining time of the auto stop time/ERV delay time – Solid: Hour unit, Blinking: Minute unit Displays Demand Response Mode during a Demand Response Event :  (It is applicable to some models for Australia only.)
	18 Restricted Central Filter	Displays invalid operation/central control/filter cleaning (filter cleaning period)
	19 	Displays check/partial locking/full locking
	20 	Displays Indirect/Direct/Outdoor air supply intake/Humidifying/External interconnection control/Range hood
	21 	Displays S-Plasma Ion operation/Air purity level
	22 CO ₂ 	Displays indoor CO ₂ density
	23 Humidity 	Displays indoor humidity
	24 Clean	Displays Clean operation

Wired Remote Controller > MWR-WE13UN





Buttons





Wired Remote Controller › MWR-WE13UN

Classification	Button	Function	
Air conditioner related information	01 	Operation On/Off button	Turns the air conditioner power On/Off
	02 	Mode button	Selects the desired air conditioner operation
	03 	Temperature setting button	Sets the desired temperature
	04 	Fan speed button	Changes the air conditioner's fan speed
	05 	Air Flow button	Changes the air flow direction
	06 	Room temperature button	Checks the indoor temperature
	07 	Blade button	Selects a blade for individual control
	08 	Wind-Free button	Selects Wind-Free Cooling operation
	09 	Quiet/Sleep button	Selects Quiet or Sleep operation for the air conditioner
	10 	Outdoor air intake/ Humidity button	Selects the MINI AHU indoor unit Outdoor intake function/ turns MINI AHU indoor unit humidifying function On/Off
	11 	Away / Motion detect sensor button	Selects when you want the Indirect/Direct function to operate by detecting people in the room, or the air conditioner to turn on or off automatically.
Common function related information	12 	User Set button	Selects the detailed setting function
	13 	Schedule Button	Selects the schedule setting function
	14 	ESC button	Returns to general mode from schedule and detailed setting screens
	15 	Delete button	Cancel the schedule setting
	16 	Directional buttons	Moves between items or change the item value
	17 	Set button	Saves your new settings
	18 	Clean button	Selects Clean operation
	19 	Filter Reset button	Turns off the filter cleaning displays (filter using time reset)
	Common function related information	20 	S-Plasma Ion button
21 		Long button	Selects Long reach function

Wired Remote Controller > MWR-WE13UN

Classification	Button	Function	
Ventilator (ERV) related buttons	22 	Operation On/Off button	Turns the Ventilator(ERV) On/Off
	23 	Mode button	Selects the desired operation for the Ventilator (ERV)
	24 	Fan Speed button	Changes the fan speed for your Ventilator (ERV)
	25 	E.Saver button	Starts Energy-Saving Operation
	26 	Clean up button	Selects air purification through the in/out load controls

 **Note**

- Some functions may not be available, depending on the indoor unit specifications.
- After cleaning the filter, please press the  button. The Filter indicator will turn off, and it will be turned on again upon the next cleaning period.
- If you press a functional button not supported by the indoor unit, then the Restricted indicator will turn on.
- If the temperature display setting is set to indoor temperature and you press the  button, the Restricted indicator appears. (When you install the wired remote controller, the setting is available.)
- If you press the  when your Ventilator(ERV) is connected to a wired remote controller, then the air conditioner and the Ventilator(ERV) might operate or stop at the same time or only the air conditioner might operate or stop. The factory setting is set to simultaneous operation/stop. (When you install the wired remote controller, the setting is available.)
- Although the air conditioner and the Ventilator (ERV) are set to simultaneous operation/stop, you can individually control the air conditioner and the Ventilator (ERV) by using another controller (e.g. wireless remote controller, centralized controller) except for a wired remote controller.

Wired Remote Controller > MWR-WE13UN

Description of parts (PCB)

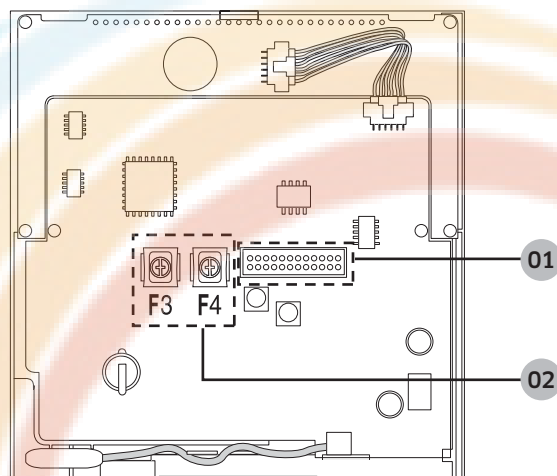

No.	Name	Description
01	Software upgrade connector	It is used to upgrade the software
02	Communication and power wiring terminal	Connection with indoor unit (F3/F4)

Note

- MWR-WE13UN uses 2-wire power line communication.

Option function

User setting mode

Main menu	Sub menu	Function	SEG Used	Default	Range	Unit
1		Auto stop time setting/ checking	1, 2	0	0~12 hours	1 hour
2	Temp limits [°C (°F)]	Lower Limit	1, 2	8 (47)	8~30°C (47~86°F)1)*	1°C (1°F)
		Upper Limit	3, 4	30 (86)	8~30°C (47~86°F)1)*	1°C (1°F)
3	Lock of partial button	All locking	1	0	0~Unlock, 1~Lock	-
		Lock of Operation On/Off button	2	0	0~Unlock, 1~Lock	-
		Lock of Mode button	3	0	0~Unlock, 1~Lock	-
		Lock of temperature setting button	4	0	0~Unlock, 1~Lock	-
		Lock of fan speed button	5	0	0~Unlock, 1~Lock	-
		Lock of schedule setting button	6	0	0~Unlock, 1~Lock	-
4	1	Current Time Setting (Year, Month, Date)	1, 2/ 3, 4/ 5, 6	13/ 01/ 01	00~99/ 1~12/ 1~31	YY, MM, DD
	2	Current Time Setting (Day, Hour, Minute)	Day/ AM, PM/ 1, 2/ 3, 4	Tuesday/ PM/12/00	Sun~Sat/ AM~PM/ 0~12/ 0~59	Day, hour, minute

Wired Remote Controller > MWR-WE13UN

Main menu	Sub menu	Function	SEG Used	Default	Range	Unit	
5	1	Summer Time Use and Setting Methods	Use of summer time (Y/N)	1	0	0-No use,1-Use	-
		Summer Time Application Method	2	0	0- Weekly,1- Daily	-	
	2	Summer time use (Weekly) Start (? Month, ? th Sunday)	1,2/4	03/F	1~12th month/ 1~4, F (last week)th week	-	
	3	Summer time use (Weekly) End (? Month, ? th Sunday)	1,2/4	10/F	1~12th month/ 1~4, F (last week)th week	-	
	4	Summer time use (Daily) Start (? Month, ? Date)	1,2/3,4	03/22	Jan~Dec/1~31st day	Month, date	
5	Summer time use (Daily) End (? Month, ? Date)	1,2/3,4	09/22	Jan~Dec/1~31st day	Month, date		
6	Backlight Time Setting/ Checking		1,2	5	0~30 sec	1 sec	
	Use of LED (Green) (Y/N)		3	1	0-No use,1-Use	-	
	Use of LED (Red) (Y/N)		4	1	0-No use,1-Use	-	
	Turning on or off the Air purity level lighting function of the indoor unit		5	1	0-Off,1-On	-	
7	Ventilator (ERV) delay time setting/checking [When using Ventilator (ERV) interlocking control]	Ventilator (ERV) Delay Application (Y/N)	1	0	0-No use,1-Use	-	
		Delay Time	3,4	30	30~60 minutes	1 minute	
8	Easy Tuning		1,2	0	-2~+2	1	
0	1	Reset to user mode defaults (except the current time)	1	0	0-No use,1-Reset	-	

Note

- ‘Summer Time’ means ‘Daylight Saving Time’.

How to set the user mode

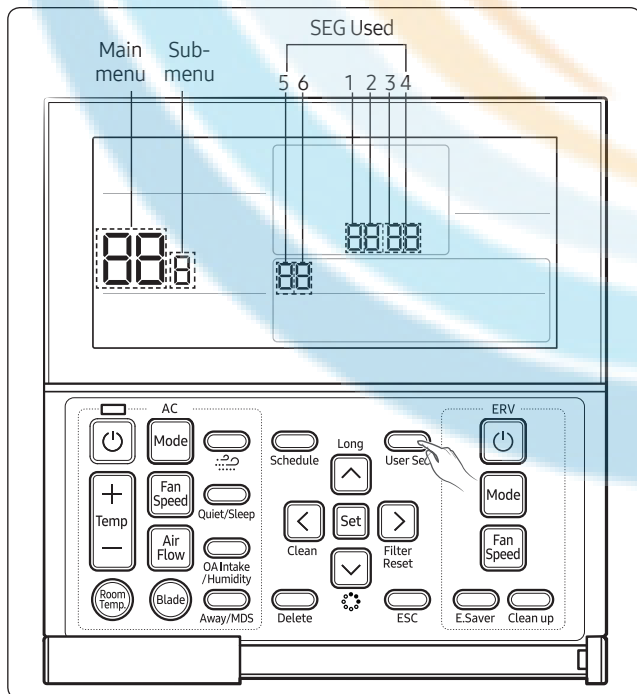

- 1 If you want to set the detailed settings, press the [User Set] button. You will enter the User Set mode, and the [Main Menu] will be displayed.
- 2 Refer to the Wired Remote Controller’s user setting mode table on the previous page to select the desired menu.
 - a Using the [^]/[v] buttons, select a main menu number and press the [>] button to enter the sub-menu setting screen.
 - b Using the [^]/[v] buttons, select a sub-menu number and press the [>] button to enter the data setting screen.
 - c Once you have entered the setting screen, the current setting will be displayed.
 - d Refer to the chart for data setting.
 - e Using the [^]/[v] buttons, change the settings and press the [>] button to move to the next setting.
 - f Press the Set button to save the setting and exit to the sub-menu setting screen.
 - g Press the Esc button to exit to general mode.

Wired Remote Controller > MWR-WE13UN

Note

- While setting the data, you can use the [^]/[v] buttons to set the range of SEG used.
- While configuring the setting, press the [Esc] button to exit to the sub-menu setting screen without saving the setting.

Current time setting (Example)

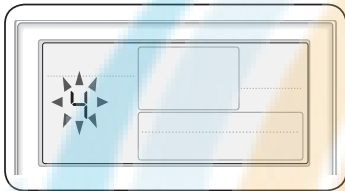

1 Press the [User Set] button.
(Main Menu) will be displayed, and you can press the [^]/[v] buttons to select No.4, which will set the current time.

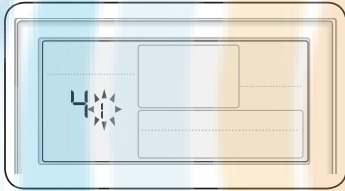

2 Press the [>] button to select 'Year, Month, Date' in the [Sub-menu].
Press the [^]/[v] buttons to select No.1. You can modify the year/month/date setting.



3 Press the [>] button to select the 'Year'.
Press the [^]/[v] buttons to select the year ('00~'99).



4 Press the [>] button to select the 'Month'.
Press the [^]/[v] buttons to select month(01~12).

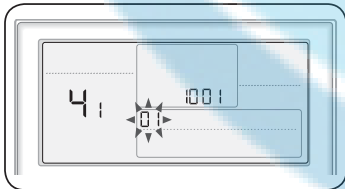

5 Press the [>] button to select the 'Day'.
Press the [^]/[v] buttons to select day(01~31).

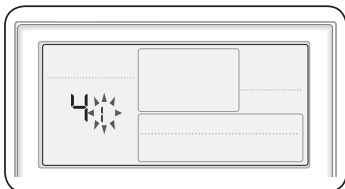

6 Press the [Set] button to complete your setting of 'Year, Month, Day'.
The setting changes will be applied and you can exit to the sub-menu.

Wired Remote Controller > MWR-WE13UN

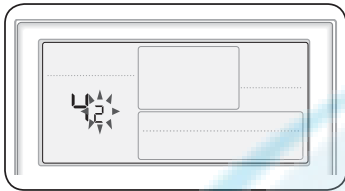

- 7** In the sub-menu, select 'day, AM/PM, hour, minute'.
Press the [^]/[v] buttons to select no.2. You can set the 'day, AM/PM, hour, minute'.

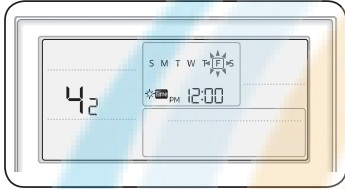

- 8** Press the [>] button to select the 'Day'.
Press the [^]/[v] buttons to select day (Sun~Sat).

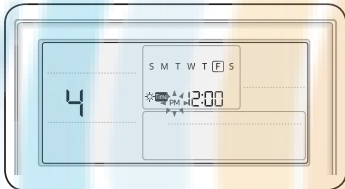

- 9** Press the [>] button to select 'AM or PM'.
Press the [^]/[v] buttons to toggle between AM and PM.

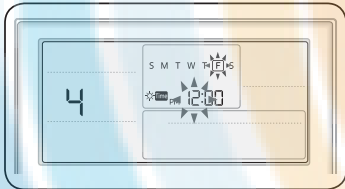

- 10** Press the [>] button to select the 'Hour'.
Press the [^]/[v] buttons to select the hour (01~12).

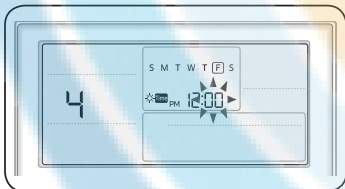

- 11** Press the [>] button to select the 'Minute'.
Press the [^]/[v] buttons to select minute (00~59).

- 12** Press the [Set] button to complete the current time setting.
The setting changes are applied and you can exit to general mode.

- 13** Press the [Esc] button to exit to general mode.

Wired Remote Controller > MWR-WE13UN

Service mode

Main menu	Sub menu	Function	Data bit	Factory setting	Description	Unit		
1	1	Wired remote controller Option setting/checking (1)	Cooling/Heating selection	1	0	0 – Cooling/Heating, 1 – Cooling only	-	
			Use of wireless remote controller	2	1	0 – No use, 1 - Use	-	
			MAIN/SUB wired remote controller	3	0	0 –MAIN, 1- SUB	-	
			Temperature unit	4	0	0 – Celcius(°C), 1 – Fahrenheit(°F)	-	
	2	Wired remote controller Option setting/checking (2)	Temperature sensor selection	1	0	0 – Indoor unit, 1 – Wired remote controller	-	
			Use of average temperature	2	0	0 – No use, 1 - Use	-	
			Use of Auto mode	3	1	0 – No use, 1 - Use	-	
			Temperature display	4	0	0 – Set temperature, 1 - Room temperature	-	
			AC On/Off button function	5	1	0 – Indoor unit + ERV, 1 – Indoor unit only, 2 – ERV only	-	
	3	Blade setting/checking	Lock of Blade1	1	0	0 – Unlock, 1 – lock	-	
			Lock of Blade2	2	0	0 – Unlock, 1 – lock	-	
			Lock of Blade3	3	0	0 – Unlock, 1 – lock	-	
			Lock of Blade4	4	0	0 – Unlock, 1 – lock	-	
	4	ERV option Setting/checking	Use of By-Pass mode	1	0	0 – No use, 1 - Use	-	
			Use of Auto mode	2	0	0 – No use, 1 - Use	-	
			Use of air purification mode	3	0	0 – No use, 1 - Use	-	
			Use of external control	4	0	0 – No use, 1 - Use	-	
	5	Room Temperature compensation	Temperature control reference	1,2,3	0	-9 ~ 40 °C(15~104 °F)	0.1 °C	
			Temperature compensation value	4,5,6	0	-9.9 ~ 9.9 °C	0.1 °C	
	6	Number of connected units	Number of indoor units	1,2	-	0 ~ 16	-	
			Number of ERVs	3,4	-	0 ~ 16	-	
	7	Desired temperature increment/decrement (°C only)		1	0	0-1 °C, 1-0.5 °C, 2-0.1 °C	-	
	8	Set/Check ERV Energy saving operation	Select individual Energy saving operation	1	0	0-ON/OFF alternating operation, 1-Outdoor air cooling operation for different temperature setting	-	
			Minimum temperature of outdoor air cooling	3,4	15	5 ~ 15 °C (41~59 °F)	°C	
	0	Factory option setting		1	0	0 – Unchanged 1 – Factory setting	-	
	2	1	Software code		1~6	-	Software code	-
		2	Software version		1~6	-	Software version	-

Wired Remote Controller > MWR-WE13UN

Main menu	Sub menu	Function	Data bit	Factory setting	Description	Unit	
3	1	Indoor unit room temperature	1,2,3	-	Room temperature	°C	
	2	Indoor unit EVA IN temperature	1,2,3	-	EVA IN temperature	°C	
	3	Indoor unit EVA OUT temperature	1,2,3	-	EVA OUT temperature	°C	
	4	Indoor unit EEV step	1,2,3	-	EEV step	-	
	5	Indoor unit option checking (1)	Use of central control	1	-	0 – No use, 1 - Use	-
			Use of drain pump	2	-	0 – No use, 1 - Use	-
			Use of electric heater	3	-	0 – No use, 1 - Use	-
			Use of hot water coil	4	-	0 – No use, 1 - Use	-
	6	Indoor unit option checking (2)	Use of external control	1	-	0 – No use, 1 - Use	-
			Use of RPM compensation	2	-	0 – No use, 1 - Use	-
Filter time			3	-	0 – 2000 hours, 1 – 1000 hours	-	
Heating temperature compensation			4	-	0-2 °C, 1-5 °C	-	
EEV stop step in heating			5	-	0 – 1/80 steps, 1 – 80	-	
4	1	Setting/Checking the address	12	-	MAIN address (00H~4FH)	-	
			34	-	MAIN address (00H~4FH)	-	
			56	-	Group address (00H~FEH)	-	
	2	Indoor unit/ Ventilator (ERV) option setting ^{2)*}	Setting/Checking the product option	1)*	-	Refer to the installation manual of the connected indoor unit/ventilator (ERV)	-
	3		Setting/Checking the installation option 1	1)*	-		-
	4		Setting/Checking the installation option 2	1)*	-		-
7	MCU/Port address setting		1,2,4	-	MCU address (00 to 15) Port address (A to F)		-
5	1	Mini AHU setting/ checking	RPM setting/checking	3,4	-	0~31 steps	1 step
			Humidity setting/checking	6	-	0 – 30, 1 - 40, 2 - 50	-
	2	Setting/Checking the discharge temperature of the indoor unit	Use of discharge temperature control	1	-	0 – No use, 1 - Use	-
			Cooling discharge temperature	3,4	-	8~25 °C (46~77 °F)	1 °C
			Heating discharge temperature	5,6	-	18~43 °C (64~109 °F)	1 °C
	3	Fresh Duct discharge temperature checking	Cooling discharge temperature	1,2	-	13~25 °C (55.4~77 °F)	1 °C
Heating discharge temperature			3,4	-	18~30 °C (64~86 °F)	1 °C	

Wired Remote Controller > MWR-WE13UN

Main menu	Sub menu	Function		Data bit	Factory setting	Description	Unit
6	1	ERV Plus setting/ checking	Use of cold air prevention	1	-	0 – No use, 1 - Use	-
			Use of humidification when Heating thermo off	2	-	0 – No use, 1 - Use	-
			Use of fan operation in Defrost	3	-	0 – No use, 1 - Use	-
			Use of humidification when Heating	4	-	0 – No use, 1 - Use	-
	2	ERV Plus temperature setting/checking	Cooling	1,2	-	15~30 °C (59~86 °F)	1 °C
			Heating	3,4	-	15~30 °C (59~86 °F)	1 °C
	3	ERV Plus Auto mode temperature setting/checking	Set temperature	1,2	-	15~30 °C (59~86 °F)	1 °C
			Set temperature difference	3,4	-	5~15 °C (41~59 °F)	1 °C
	4	Setting/checking the compensating temperature A under the Heating EEV control for ERV Plus		1,2	-	0~10 °C	1 °C
		Checking the compensating temperature B under the Heating EEV control for ERV Plus		3	-	0 – Non use of humidifier (0 °C/32 °F) 1 – Use humidifier(10 °C/50 °F)	-
5	ERV Plus fan RPM setting/checking	Air supply RPM	1,2	-	10~27 steps	1 step	
		Air exhaustion RPM	3,4	-	10~27 steps	1 step	
7	1	View master setting/ checking	Indoor unit View master setting/checking	123456	-	address	-
	2	(F3F4 line Indoor unit master)	ERV unit View master setting/ checking	123456	-	address	-
	3	Mode master indoor unit setting/checking	Mode master indoor unit checking	123456	-	address	-
	4	(F1F2 line Indoor unit master) ^{3)*}	Mode master indoor unit setting	1	-	0-No use, 1-Use, 2-Release	-
8	1	Status of Automatic Air-Volume setting		1	0	0 – OFF (Disabled or Cancelled) 1 – Completion 2 – Running Automatic Air-Volume	-
	2	Automatic Air-Volume Operation		1	0	0 – Disable, 1 – Enable	-
	3	Automatic Air-Volume Voltage Setting		1	2	1~3 steps (2 - Default) For the specific voltage of model, please refer to the installation manual of each product.	-
0	1	Reset	Factory setting	1	0	0-No use, 1-Reset	-
	2		Power Master Reset ^{4)*}	1	0	0-No use, 1-Reset	-
	3		Addressing Reset	1	0	0-No use, 1-Reset	-

 Note

- 'NONE' will be displayed if the indoor unit does not support the function. In some cases, the setting may not be possible or it may not be applied though it is set on the unit.
- If communication initialization is needed after the setting, the system will reset automatically and communication will be initialized.

Wired Remote Controller > MWR-WE13UN

1)* The total option codes are 24 digits. You can set six digits at a time and it is distinguished by page number. Press [>] button to go to the next page.

- To set 24 digit option

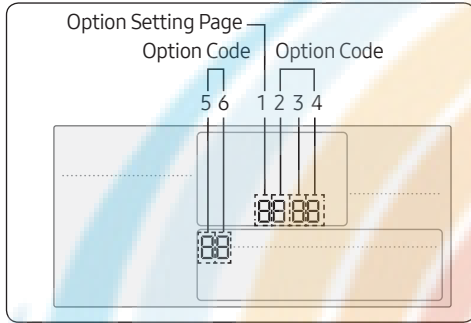

SEG1	SEG2	SEG3	SEG4	SEG5	SEG6
0	*	*	*	*	*

Page number

SEG7	SEG8	SEG9	SEG10	SEG11	SEG12
1	*	*	*	*	*

Page number

SEG13	SEG14	SEG15	SEG16	SEG17	SEG18
2	*	*	*	*	*

Page number

SEG19	SEG20	SEG21	SEG22	SEG23	SEG24
3	*	*	*	*	*

Page number

※ Regardless of Celsius and Fahrenheit setting, service mode setting is available only with Celsius.

- 2)* If you enter Main menu #4, you must select the targeted indoor unit/ventilator (ERV) address and then select the sub menu.
- 3)* Setting is available when there is only 1 indoor unit connection and while the indoor unit operation is not operating.
- 4)* Power Master Reset is a setting needed to supply optimized power to wired remote controller when multiple indoor units are connected to wired remote controller in a group.

Note

- Address is displayed in hexadecimal. Please refer to the following table.

Hexadecimal	Decimal	Hexadecimal	Decimal	Hexadecimal	Decimal	Hexadecimal	Decimal	Hexadecimal	Decimal
00	0	10	16	20	32	30	48	40	64
01	1	11	17	21	33	31	49	41	65
02	2	12	18	22	34	32	50	42	66
03	3	13	19	23	35	33	51	43	67
04	4	14	20	24	36	34	52	44	68
05	5	15	21	25	37	35	53	45	69
06	6	16	22	26	38	36	54	46	70
07	7	17	23	27	39	37	55	47	71
08	8	18	24	28	40	38	56	48	72
09	9	19	25	29	41	39	57	49	73
0A	10	1A	26	2A	42	3A	58	4A	74
0B	11	1B	27	2B	43	3B	59	4B	75
0C	12	1C	28	2C	44	3C	60	4C	76
0D	13	1D	29	2D	45	3D	61	4D	77
0E	14	1E	30	2E	46	3E	62	4E	78
0F	15	1F	31	2F	47	3F	63	4F	79

Wired Remote Controller > MWR-WE13UN

How to set the service mode

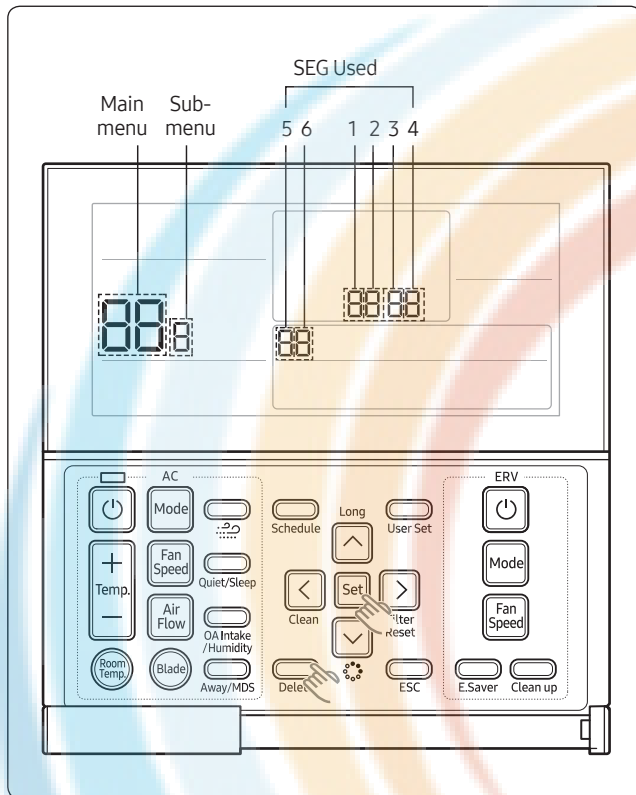

- 1** If you want to use the various additional functions for your Wired Remote Controller, press the [Set] and [Esc] buttons at the same time for more than three seconds. You will enter the additional function settings, and the [main menu] will be displayed.
- 2** Refer to the list of additional functions for your Wired Remote Controller on the next page, and select the desired menu.
 - a** Using the [^]/[v] buttons, select a main menu number and press the [>] button to enter the sub-menu setting screen.
 - b** Using the [^]/[v] buttons, select a sub-menu number and press the [>] button to enter the data setting screen.
 - c** When you enter the setting stage, the current setting will be displayed.
 - d** Refer to the chart for data setting.
 - e** Using the [^]/[v] buttons, select the settings. Press the [>] button to move to the next setting.
 - f** Press the [Set] button to save the settings and exit to the sub-menu setting screen.
 - g** Press the [Esc] button to exit to normal mode.

Note

- While setting the data, you can use the [<]/[>] buttons to set the range of SEG.
- While configuring the setting, press the [Esc] button to exit to the setting sub-menu without saving your changes.

Wired Remote Controller › MWR-WE13UN

Example method of setting wired remote controller option

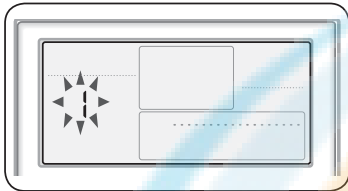

1 Press the [Set] and [ESC] buttons at the same time for more than 3 seconds. When(Main menu) is displayed press the [^]/[v] button to select no.1.

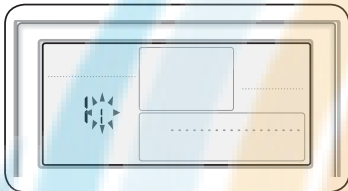

2 Press the [>] button to select the number you will set. Press the [^]/[v] button and select no.1

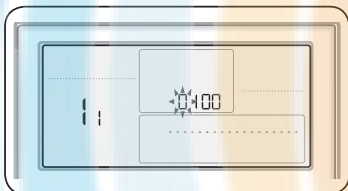

3 Press the [>] button to enter the data setting stage. When you enter the setting stage, the current setting value will be displayed.

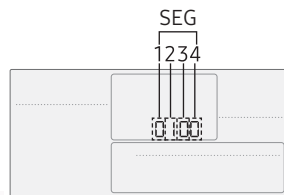

SEG1: Heat pump indoor unit
 SEG2: Use wireless remote controller
 SEG3: Master wired remote controller
 SEG4: Temperature display – Celsius (°C)

◁Example of data setting stage display▷



4 Press the [<]/[>] button to select the desired Data1.

- Press the [^]/[v] button to select no.1.
- The wired remote controller option is set from both cooling and heating to cooling only.

5 Press [Set] button to complete the option setting. Save the setting value and exit to sub menu.

6 Press [Esc] button to exit to normal mode.

Wired Remote Controller > MWR-WE13UN

Built-in temperature sensor of wired remote controller

Temperature control with built-in temperature sensor

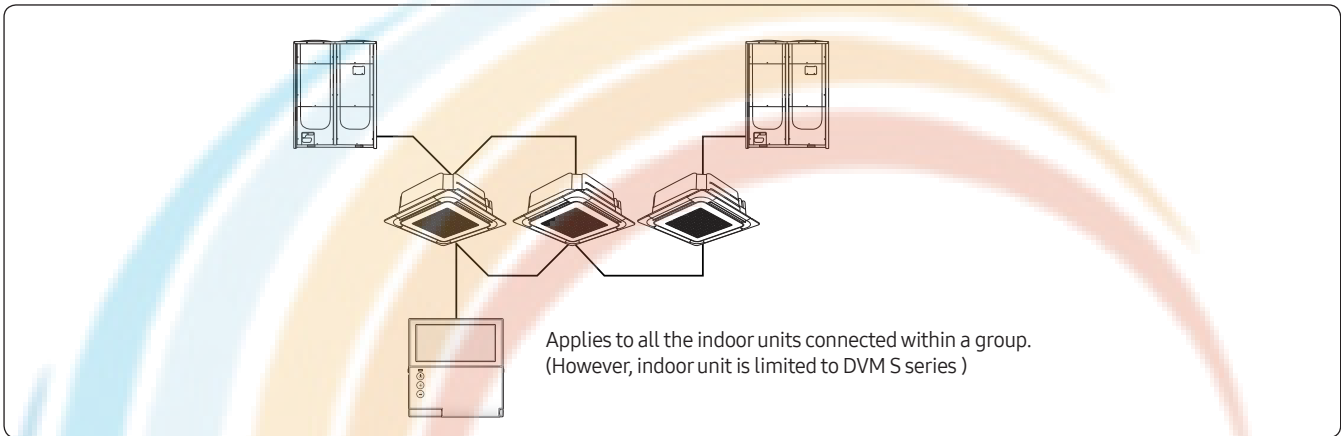

Note

- Check the setting of the wired remote controller built-in sensor from the service menu.

Main menu	Sub menu	Function	Used SEG	Factory setting	Description	Unit	
1	1	Wireless remote controller Option setting/checking (1)	Cooling/Heating selection	1	0	0-Cooling/Heating, 1-Cooling only	-
			Use of wireless remote controller	2	1	0-No use, 1-Use	-
			MAIN/SUB wired remote controller	3	0	0-MAIN, 1-SUB	-
			Temperature unit	4	0	0-Celsius(°C), 1-Fahrenheit(°F)	-
	2	Wireless remote controller Option setting/checking (2)	Temperature sensor selection	1	0	0-Indoor unit, 1-Wired remote controller	-
			Use of average temperature	2	0	0-No use, 1-Use	-
			Use of Auto mode	3	1	0-No use, 1-Use	-
			Temperature display	4	0	0-Set temperature, 1-Room temperature	-
			AC On/Off button function	5	0	0-Indoor unit+ERV, 1-Indoor unit only, 2-ERV only	-

Wired Remote Controller > MWR-WE13UN

Heating mode temperature compensation

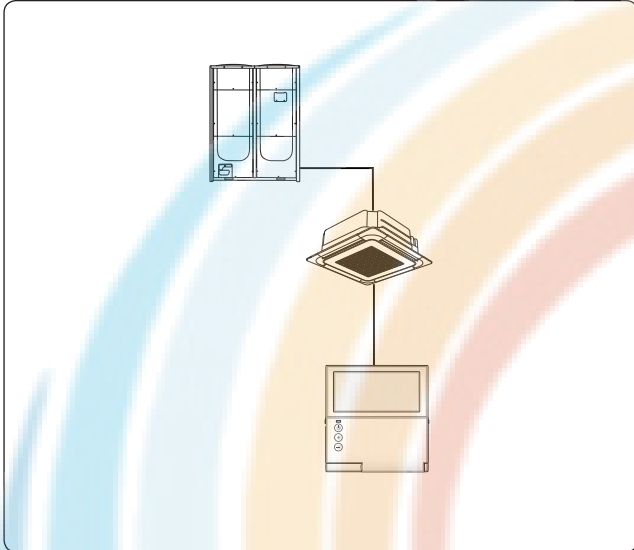

Indoor unit INSTALL option setting
(Refer to indoor unit intallation manual)

SEG	Function	Value
21	Heating setting temperature compensation	1 – 2°C(°F) 2 – 5°C(°F)

Note

- When built-in sensor of the wired remote controller is used, heating mode temperature compensation (+2°C or +5°C) will be reset to 0°C.

Note

- If there is no option switch on the indoor unit PCB, check the setting of the heating temperature compensation from the service menu.

Main menu	Sub menu	Function	Used SEG	Factory setting	Description	Unit	
3	6	Indoor unit option checking(2)	Use of external control	1	-	0-No use,1-Use	-
			Use RPM compensation	2	-	0-No use,1-Use	-
			Filter time	3	-	0-2000 hours,1-1000 hours	-
			Heating temperature compensation	4	-	0-2°C(°F),1-5°C(°F)	-
			EEV stop step in heating	5	-	0-0/80 step,1-80 step	-

Wired Remote Controller > MWR-WE13UN

When communication error or power failure occurs while using built-in temperature sensor

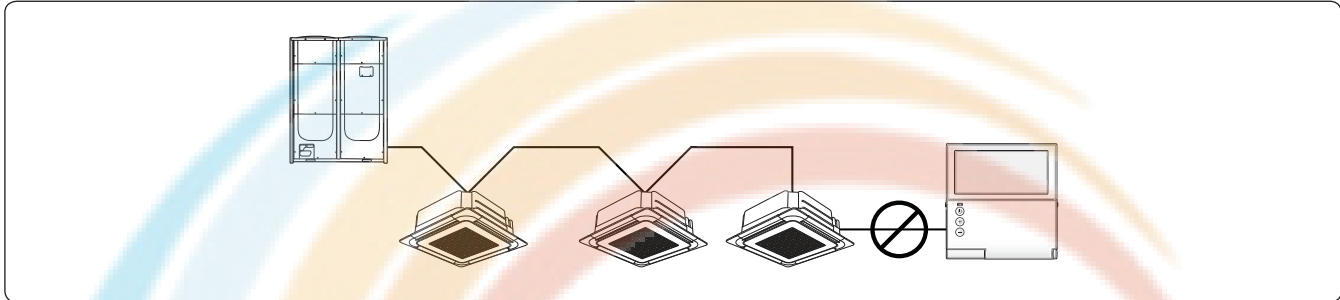

When communication error occurs over 3 minutes,

- Indoor unit ignores the built-in temperature sensor and use indoor unit temperature sensor.
- Indoor unit applies the heating setting temperature compensation.(+2°C,+5°C)

When communication resumes,

- Built-in temperature use is recovered.
- Setting must be done again to use the temperature compensation.

Wired Remote Controller > MWR-WE13UN

Display

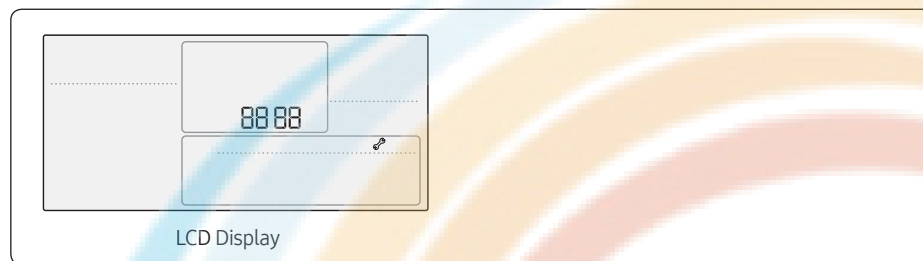

Error display

Error codes for the Wired Remote Controller and the product connected to your Wired Remote Controller will be displayed in the LCD display.

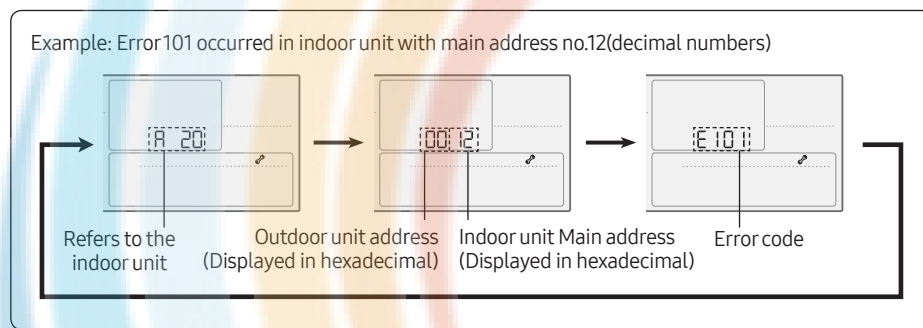

- When an Error Occurs in Your Indoor/Outdoor Units (Product Group Display: A)
The product address for the error will be displayed, followed by the error code.
Example : Error101 occurs for Indoor Unit No. 200012.

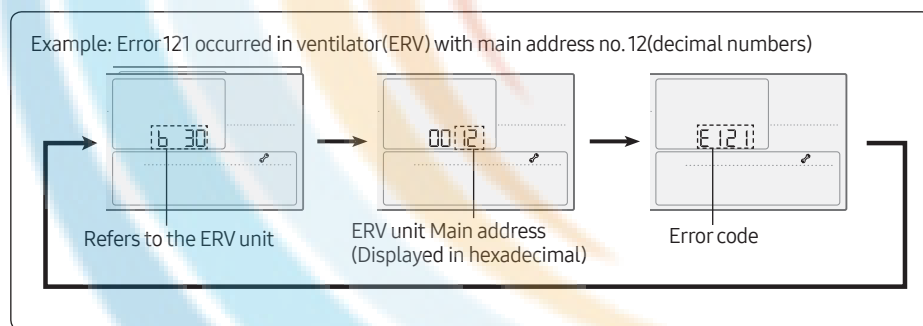

- When an Error Occurs in Your Ventilator(ERV) (Product Group Display: B)
The product address for the error will be displayed, followed by the error code.
Example : Error121 has occurred at ventilator(ERV) No. 300012.

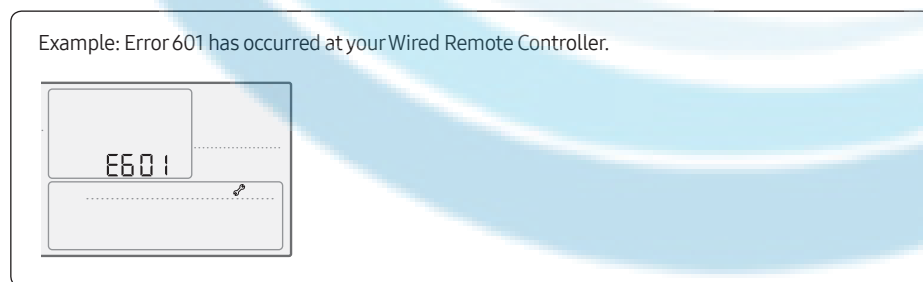

- When an Error Occurs in Your Wired Remote Controller
Only an error code will be displayed. (No address will be displayed.)
Example : Error 601 has occurred at your Wired Remote Controller.

Wired Remote Controller > MWR-WE13UN

Wired remote controller error codes

Display	Description
601	Communication error between wired remote controller and indoor/ERV units after successful communication.
602	No communication between Master(Main) and Slave(Sub) wired remote controllers.
604	When tracking between wired remote controller and indoor unit/ventilator (ERV) is not complete for more than 3 minutes (Including communication error between indoor units and outdoor units)
618	Over16 indoor/ERV indoor units installed.
627	Two or more wired remote controllers set as Slave(SUB).
653	Temperature sensor Open/Short error.
654	EEPROM error

⚠ Caution

- For the error codes for your indoor/outdoor units and ventilator(ERV), refer to the installation manual of each device.

📄 Note

Setting/Cancelling the Mode master indoor unit

- Mode master indoor unit setting is simply selecting an indoor unit that will become standard among many indoor units to prevent mixed operation (which one or more indoor units operating in different operation mode).
 - Setting: Connect just 1 indoor unit and stop the operation. Then press and hold the **Mode** button for 5 seconds to set the indoor unit as 'Mode master indoor unit'
 - Cancelling: Connect just 1 indoor unit and stop the operation. Then press and hold the **Fan speed** button for 5 seconds to cancel the 'Mode master indoor unit' setting.

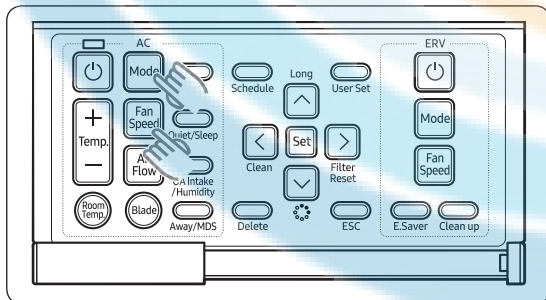

Wired Remote Controller > MWR-WE13UN

Communication diagram

Individual control (1)

Control 1 indoor unit with 1 wired remote controller

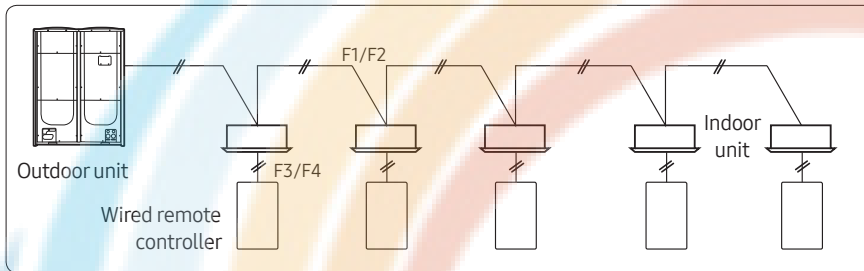

Control

- All connected indoor units

Display

- Operation status of the connected indoor unit

Group control (1)

Control multiple indoor units with 1 wired remote controller

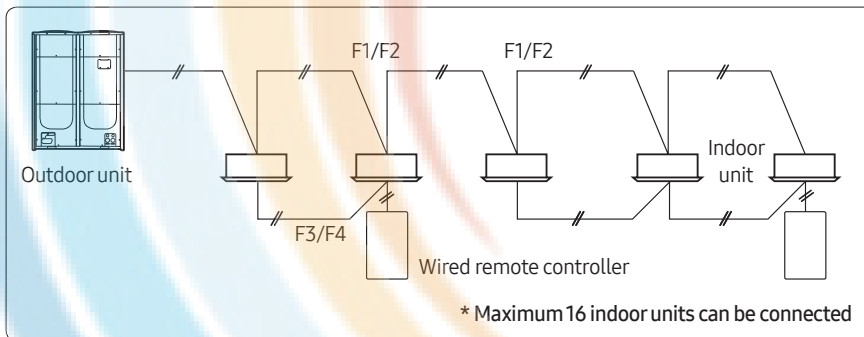

Control

- All connected indoor units

Display

- Priority 1. Display the status of View Master indoor unit
- Priority 2. Display the status of indoor unit which has the earliest Main address

Group control (2)

Control multiple indoor units connected to different outdoor units with 1 wired remote controller

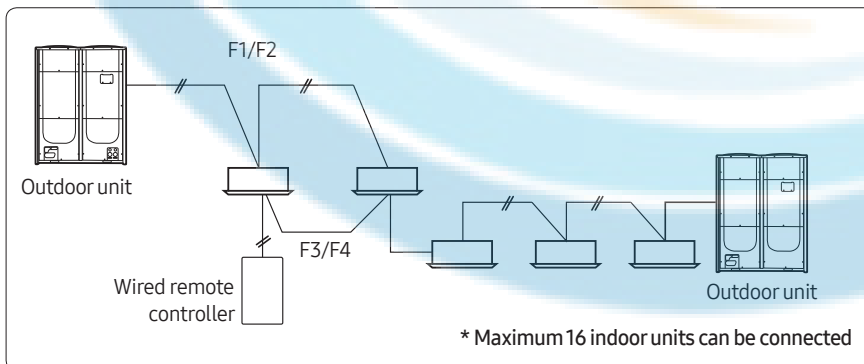

Control

- All connected indoor units

Display

- Priority 1. Display the status of View Master indoor unit
- Priority 2. Display the status of indoor unit which has the earliest Main address

⚠ Caution

- When controlling group of indoor units connected to different outdoor unit, address of the each outdoor unit must be set differently.

Wired Remote Controller > MWR-WE13UN

Group control (3)

Control 1 or multiple indoor units with 2 wired remote controllers

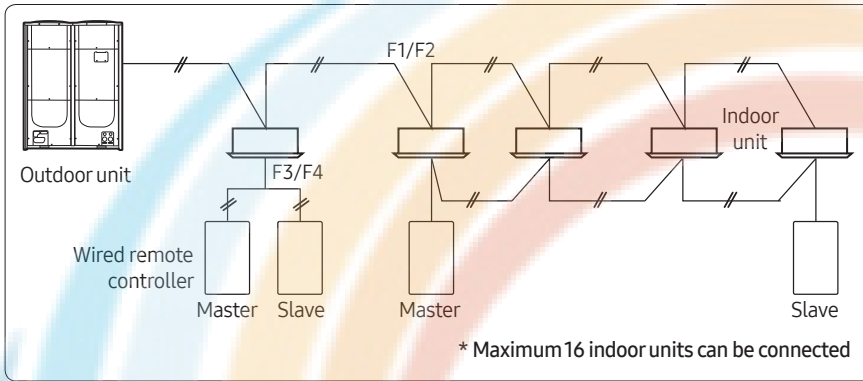

Control

- All connected indoor units

Display

- Priority 1. Display the status of View Master indoor unit
 - Priority 2. Display the status of indoor unit which has the earliest Main address
- Two wired remote controllers identically display the operation status of the indoor unit according to above priority.

Group control (4)

Control multiple indoor units connected to different outdoor units with 2 wired remote controller

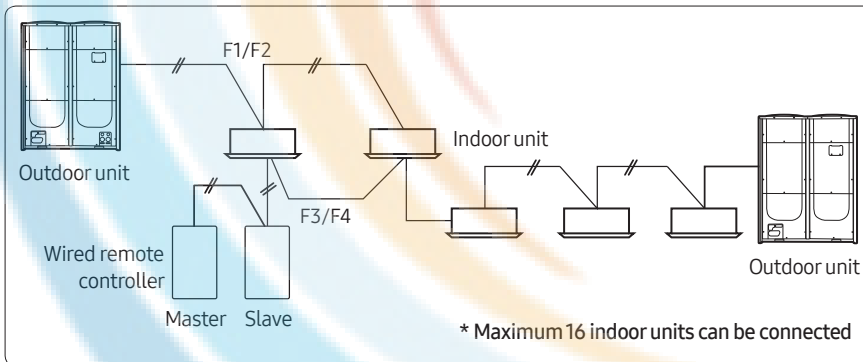

Control

- All connected indoor units

Display

- Priority 1. Display the status of View Master indoor unit
 - Priority 2. Display the status of indoor unit which has the earliest Main address
- Two wired remote controllers identically display the operation status of the indoor unit according to above priority.

⚠ Caution

- When controlling group of indoor units connected to different outdoor unit, address of the each outdoor unit must be set differently.

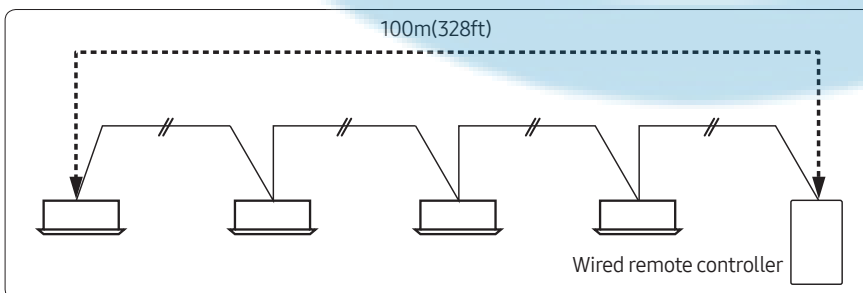

- Max. distance between the farthest indoor unit and wired remote controller: 100m(328ft)

Wired Remote Controller > MWR-SH00UN

MWR-SH00UN

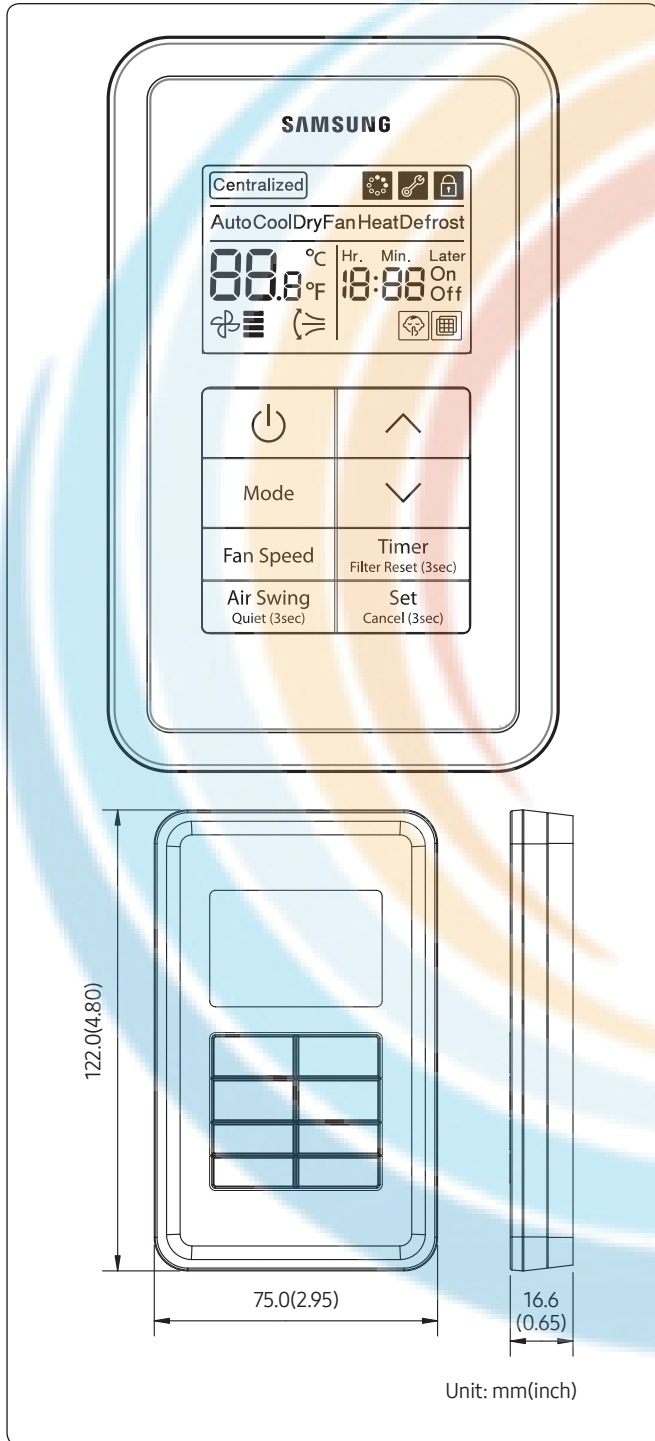

Features

- Simplified wired remote controller
- AC operation ON/OFF control
- Fan speed control
- Setting operation mode and temperature
- Reset filter cleaning alert indicator
- Adjust air flow direction
- Operation on/off timer function

Product specification

Power supply	DC12V
Power consumption	1.5 W
Operating temperature range	0°C~40°C (32°F~104°F)
Operating humidity range	30 % RH~90 % RH
Communication	2-wire PLC
Maximum length of connection	100 m (328ft)
Maximum number of controllable devices	16 indoor units

Compatible product

Indoor unit	AM****N****Model
	AC****N****Model





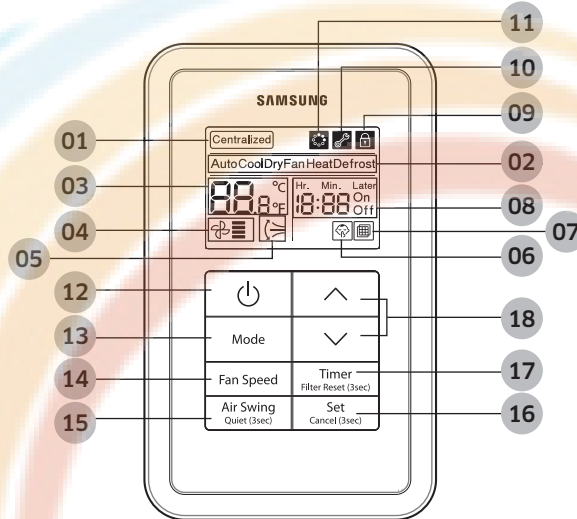



Wired Remote Controller > MWR-SH00UN

Description of parts



No.	Name	Description
01	Centralized control indicator	Indicator will be on when remote controller usage restriction is set. (Devices that support centralized control: OnOff controller, DMS2.5, Touch centralized controller etc.)
02	Operation mode indicator	Indicates current operation mode when the indoor unit is operating (Cool/Auto/Dry/Fan/Heat)
03	Set temperature indicator	Indicates the set temperature when the indoor unit turns on.
04	Fan speed indicator	Indicates the fan speed settings.
05	Air swing indicator	Indicates when vertical air swing is on.
06	Quiet mode indicator	Indicates when quiet mode is on.
07	Filter cleaning indicator	Indicates when preset filter cleaning period is passed.
08	Timer indicator	On: Indicates when On timer is set Off: Indicates when Off timer is set Hr. Min. Later: <ul style="list-style-type: none"> • Timer mode: Displays the set time for On/Off timer (Min. 30 minutes ~ Max. 18 hours) • General mode: Displays remaining time before Timer function will execute
09	Lock/Restricted indicator	This icon will be displayed when button is locked or when unavailable function (function which indoor unit does not support) is selected <ul style="list-style-type: none"> • Icon On: All buttons are locked • Icon blinks for 3 seconds: When partially locked button is pressed or unavailable function (function which indoor unit does not support) is selected
10	Inspection indicator	Indicates that inspection is required.

Wired Remote Controller > MWR-SH00UN

No.	Name	Description
11	SPI indicator	Indicates that SPI or other cleaning function of the indoor unit is on.
12	On/Off button	Press this button to turn on/off the indoor unit.
13	Mode button	Press this button to select the desired operation mode. (Auto → Cool → Dry → Fan → Heat)
14	Fan speed button	Press this button to select one of the fan speeds from Auto, Low, Medium, High, Turbo. Available Fan Speed may differ depending on the operation mode of the indoor unit. • Low  → Medium  → High  → Turbo  → Auto  →  →  → 
15	Air swing button	Press this button to turn on/off the vertical air swing when the indoor unit supports vertical air swing movement.
16	Set/Cancel button	This button can be used only for Timer, User mode, Service mode. • Short press: Set (Save) • Press and hold for 3 seconds: Cancel
17	Timer button/ Filter reset button	• Short press: You can set the On/Off timer. • Press and hold for 3 seconds: Resets the filter cleaning alert indicator.
18	Temperature adjustment/ Time adjustment button	• General mode: Press this button to increase/decrease the set temperature by preset unit. – Short press: adjust the temperature by 1°C(°F) or 0.5°C(°F) or 0.1°C(°F) depending on the setting. – Press and hold: adjust the temperature by 1°C(°F) every 0.5 second • Timer mode: Press this button to increase/decrease the set time. – Up to 3 hours: Increase/decrease by 30 minute unit – Over 3 hours: Increase/decrease by 1 hour unit

PCB

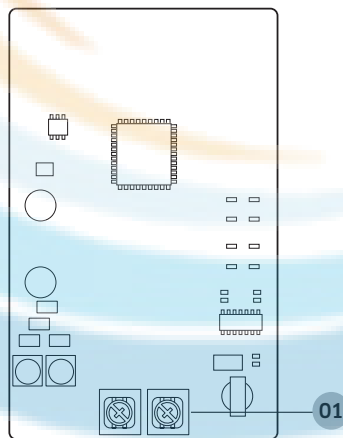

No.	Name	Description
01	Power/communication connection terminal	Connect to indoor unit (F3/F4)

Wired Remote Controller > MWR-SH00UN

Option function

User setting mode

How to set

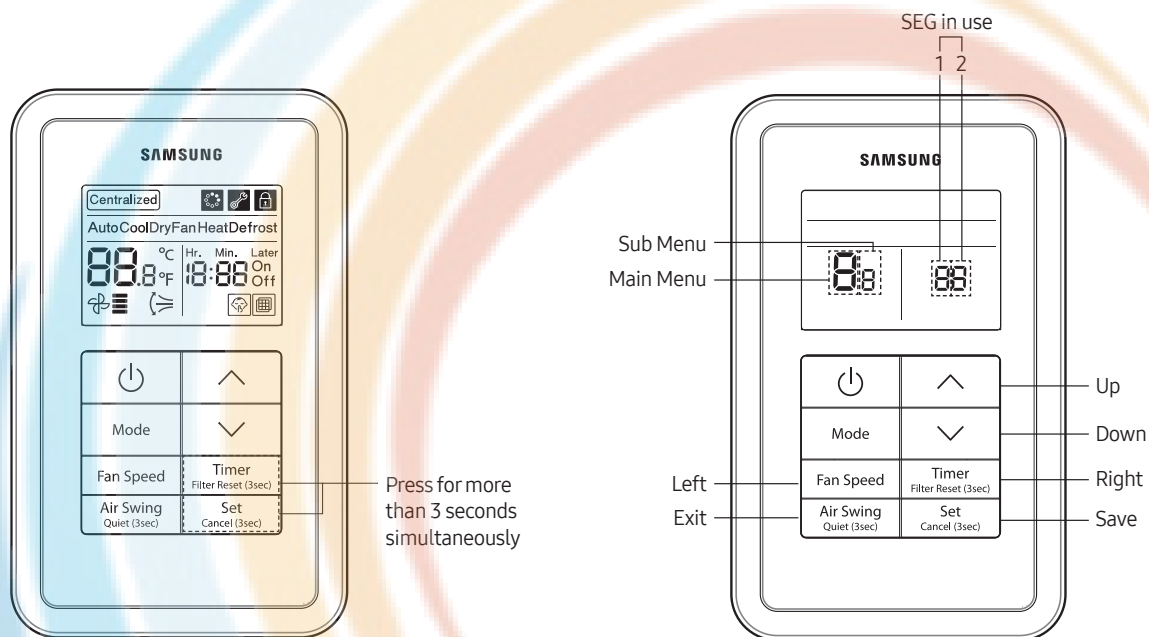

Main menu	Sub menu	Function	Default	Page in use	Range	Save	
0	1	Reset User mode to default value	0	1	0 - Disabled, 1 - Reset	none	
1	1	Lock all	0	1	0 - Unlock, 1 - Lock	o	
	2	Partially lock buttons	Lock On/Off button	0	1	0 - Unlock, 1 - Lock	o
	3		Lock Mode button	0	1	0 - Unlock, 1 - Lock	o
	4		Lock Temperature adjustment button	0	1	0 - Unlock, 1 - Lock	o
	5		Lock Fan speed button	0	1	0 - Unlock, 1 - Lock	o
	6		Lock Timer button	0	1	0 - Unlock, 1 - Lock	o
2	1	Temperature restriction	Lower temperature	16	1	16~30	o
	2		Upper temperature	30	1	16~30	o

Wired Remote Controller > MWR-SH00UN

Service mode

How to set

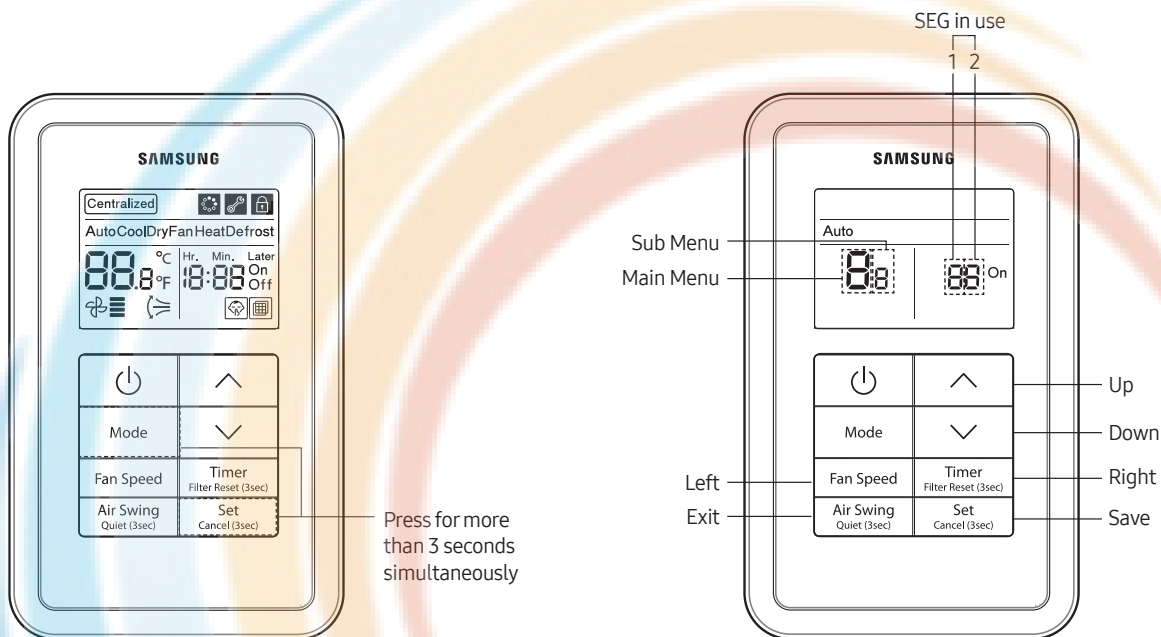

Page display

On	Page1	Page2	Page3	Page4	Page5	Off	Page6	Page7	Page8	Page9	Page10
	Auto	Cool	Dry	Fan	Heat		Auto	Cool	Dry	Fan	Heat

Main menu	Sub menu	Function	Default	Page in use	Range	
0	1	Reset	Reset the option setting of the wired remote controller to default value	0	1	0 - Disabled, 1 - Reset
	2		Reset wired remote controller to factory default	0	1	0 - Disabled, 1 - Reset
	3		Power Master Reset	0	1	0 - Disabled, 1 - Reset
	4		Addressing Reset	0	1	0 - Disabled, 1 - Reset
1	1	Wired remote controller information	Check the number of connected indoor units	0	1	0~16
	2		Check the number of connected ERV	0	1	0~16
	3		Check the MICOM code of wired remote controller	none	1~3	MICOM code
	4		Check the software version of the wired remote controller	none	1~3	Updated date

Wired Remote Controller > MWR-SH00UN

Main menu	Sub menu	Function		Default	Page in use	Range
2	1	Address/ option setting	Target indoor unit address setting	View Master indoor unit	1~3	Select address from one of the connected indoor unit Display example) Page 1: 20 (Refers to indoor unit) Page 2: 00 (Outdoor unit address) Page 3: 04 (Main address)
	2		Check/Set main address	Main address of Target indoor unit	1	Main address (00H~4FH, Hexadecimal digits)
	3		Check/Set RMC address	Main address of Target indoor unit	1	RMC(1): 0~F/ RMC(2): 0~F (Hexadecimal number) ^{1)*}
	4		Check/set the product option	Product option of target indoor unit	1~10	Option code
	5		Check/Set installation option (1)	Installation option of target indoor unit	1~10	Option code
	6		Check/Set installation option (2)	Installation option of target indoor unit (2)	1~10	Option code
3	1	Check/Set view master	Check/Set indoor unit view master	View Master indoor unit	1~3	Select address from one of the connected indoor unit (hexadecimal number)
	2		No function	-	1~3	-
4	1	Check/Set Mode master indoor unit	Check the address of the mode Master indoor unit	none	1~3	Address of the mode Master indoor units
	2		Setting the mode Master indoor unit ^{2)*}	none	1	0- Not set, 1-Set, 2-Cancel
5	1	Check/Set option function of the wired remote controller	Set indoor unit for 'cooling and heating'/'cooling only'	0	1	0- Cooling and heating, 1-Cooling only
	2		Setting wireless remote controller usage restriction	1	1	0 - Disable, 1 - Enable
	3		Setting Master/Slave wired remote controller	0	1	0-Master, 1-Slave
	4		Setting auto operation usage	1	1	0 - Disable, 1 - Enable
	5		Temperature display Celsius(°C)/ Fahrenheit(°F)	0	1	0- Celsius (°C), 1-Fahrenheit (°F)
	6		Set unit for desired temperature (0,1,2) (Only available when temperature is displayed in Celsius (°C)	0	1	0-1°C, 1-0.5°C, 2-0.1°C

1)* When RMC(1) is set as F, RCM(2) can be set up to E only.

2)* Mode master indoor unit: The indoor unit which can decide the operation mode. Other indoor unit will follow mode master indoor unit's operation mode.

Wired Remote Controller > MWR-SH00UN

Setting mode master indoor unit

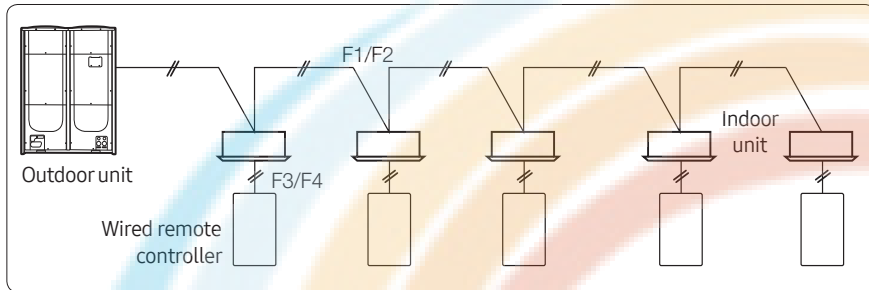

- Only when the wired remote controller is connected to an indoor unit directly (1:1 connection), you can set the mode master indoor unit that sets the operation mode of the outdoor unit.

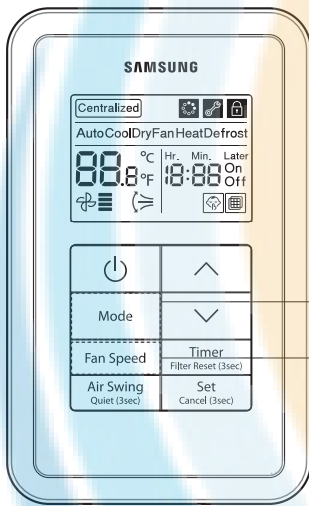

Press and hold for over 5 seconds the connected indoor unit will be set as Mode master indoor unit

Press and hold for over 5 seconds Mode master indoor unit setting will be canceled

System reset

Reset the power of the simplified wired remote controller

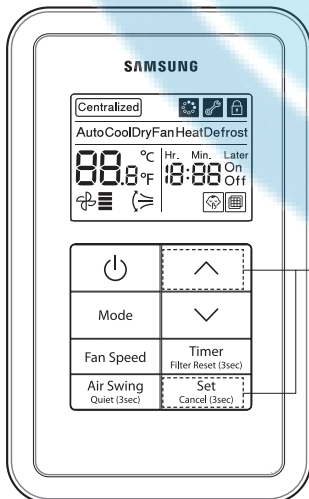

Press and hold for over 5 seconds Power reset

Wired Remote Controller > MWR-SH00UN

Display

Error display

Error codes of for the simplified wired remote controller and the product connected to it will be displayed on the LCD display.

Example: Error 121 occurs for indoor unit No. 10 (Decimal digits)

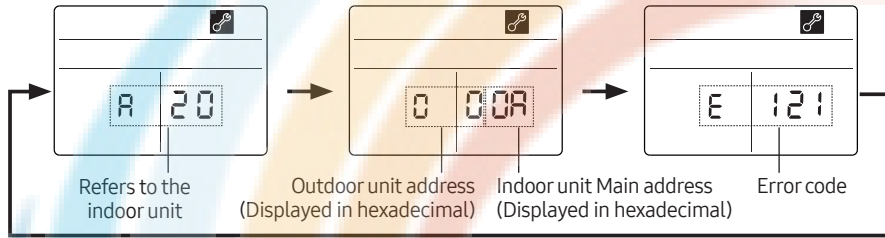

- When an error occurs in your indoor/outdoor units (Product group display: A20)
Address of the product with error code and address will be displayed alternately.

Example: Error 601 has occurred on simplified remote controller

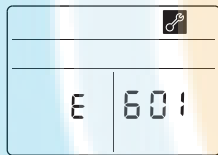

- When an error occurs in your simplified wired remote controller
Only an error code will be displayed. (No address will be displayed)

No.	Error code	Description of the error	Remarks
1	601	Communication error between wired remote controller ↔ Indoor unit	-
2	602	Communication error between Master ↔ Slave wired remote controller • Error is only detected on slave wired remote controller	-
3	604	Communication tracking error between wired remote controller ↔ Indoor unit	-
4	618	Exceeded maximum number of units (16 units)	-
5	627	Two or more wired remote controllers are set as Slave	-
6	654	Memory (external ROM) read/write error • This error is detected only during power reset. If error occurs on memory after power has turned on, it will not effect on operation of the wire remote controller display and therefore error code will not be displayed.	-

Wired Remote Controller > MWR-SH00UN

Communication diagram

Individual control (1)

Control 1 indoor unit with 1 wired remote controller

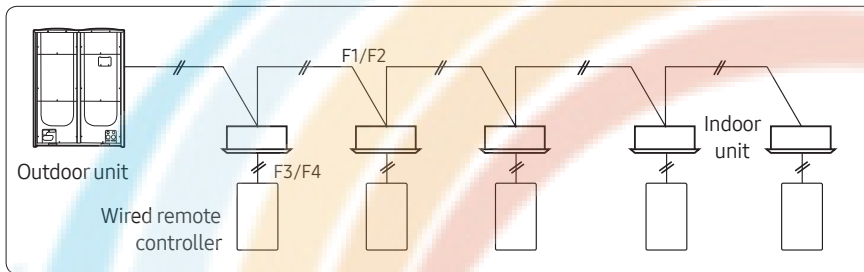

Control

- All connected indoor units

Display

- Operation status of the connected indoor unit

Group control (1)

Control multiple indoor units with 1 wired remote controller

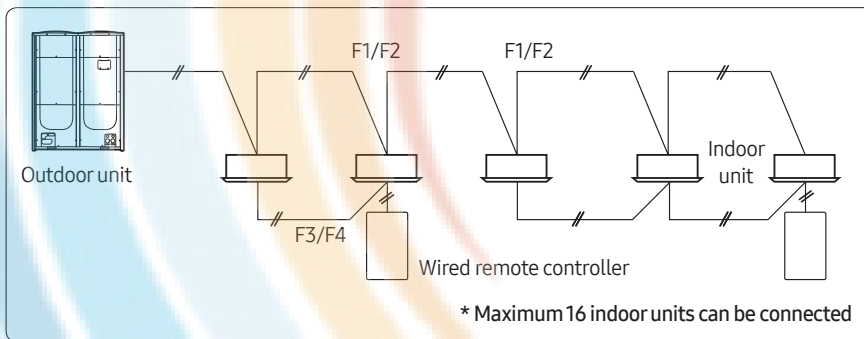

Control

- All connected indoor units

Display

- Priority 1. Display the status of view master indoor unit
- Priority 2. Display the status of indoor unit which has the earliest Main address

Group control (2)

Control multiple indoor units connected to different outdoor units with 1 wired remote controller

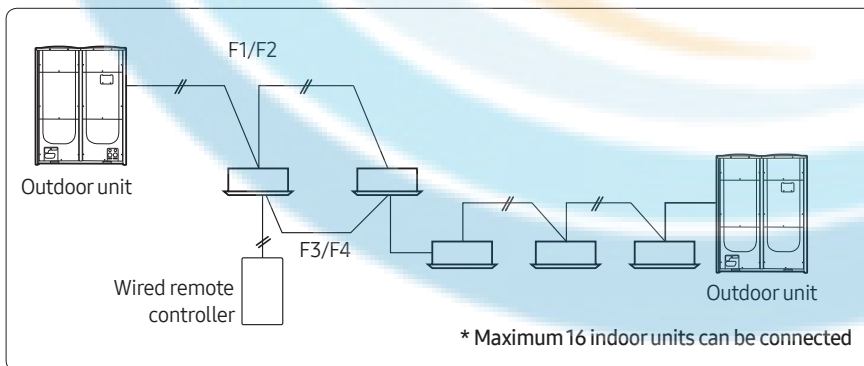

Control

- All connected indoor units

Display

- Priority 1. Display the status of view master indoor unit
- Priority 2. Display the status of indoor unit which has the earliest Main address

⚠ Caution

- When controlling group of indoor units connected to different outdoor unit, address of the each outdoor unit must be set differently.

Wired Remote Controller > MWR-SH00UN

Group control (3)

Control 1 or multiple indoor units with 2 wired remote controllers

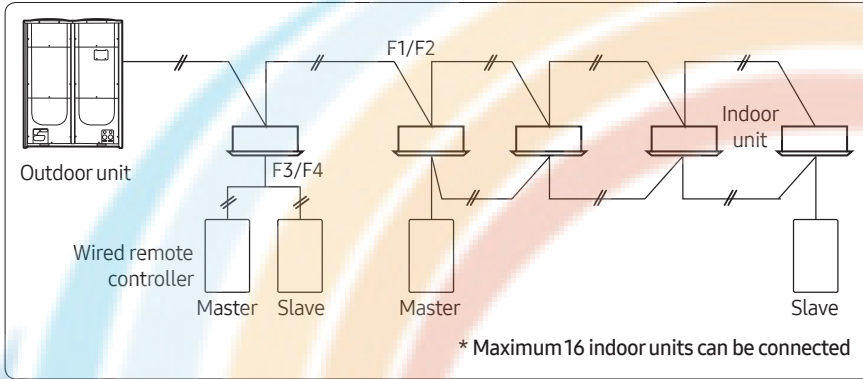

Control

- All connected indoor units

Display

- Priority 1. Display the status of View Master indoor unit
- Priority 2. Display the status of indoor unit which has the earliest Main address
 - Two wired remote controllers identically display the operation status of the indoor unit according to above priority.

Group control (4)

Control multiple indoor units connected to different outdoor units with 2 wired remote controller

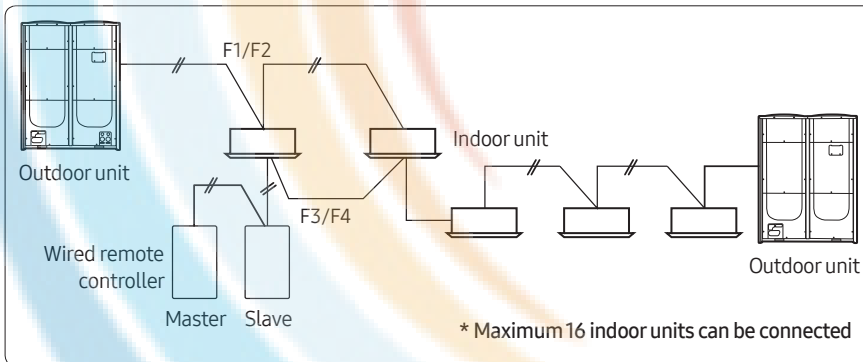

Control

- All connected indoor units

Display

- Priority 1. Display the status of View Master indoor unit
- Priority 2. Display the status of indoor unit which has the earliest Main address
 - Two wired remote controllers identically display the operation status of the indoor unit according to above priority.

⚠ Caution

- When controlling group of indoor units connected to different outdoor unit, address of the each outdoor unit must be set differently.

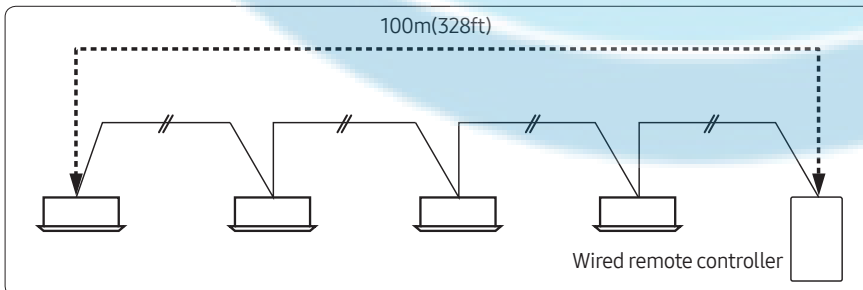

- Max. distance between the farthest indoor unit and wired remote controller: 100m(328ft)

Wired Remote Controller > MWR-SH11UN

MWR-SH11UN

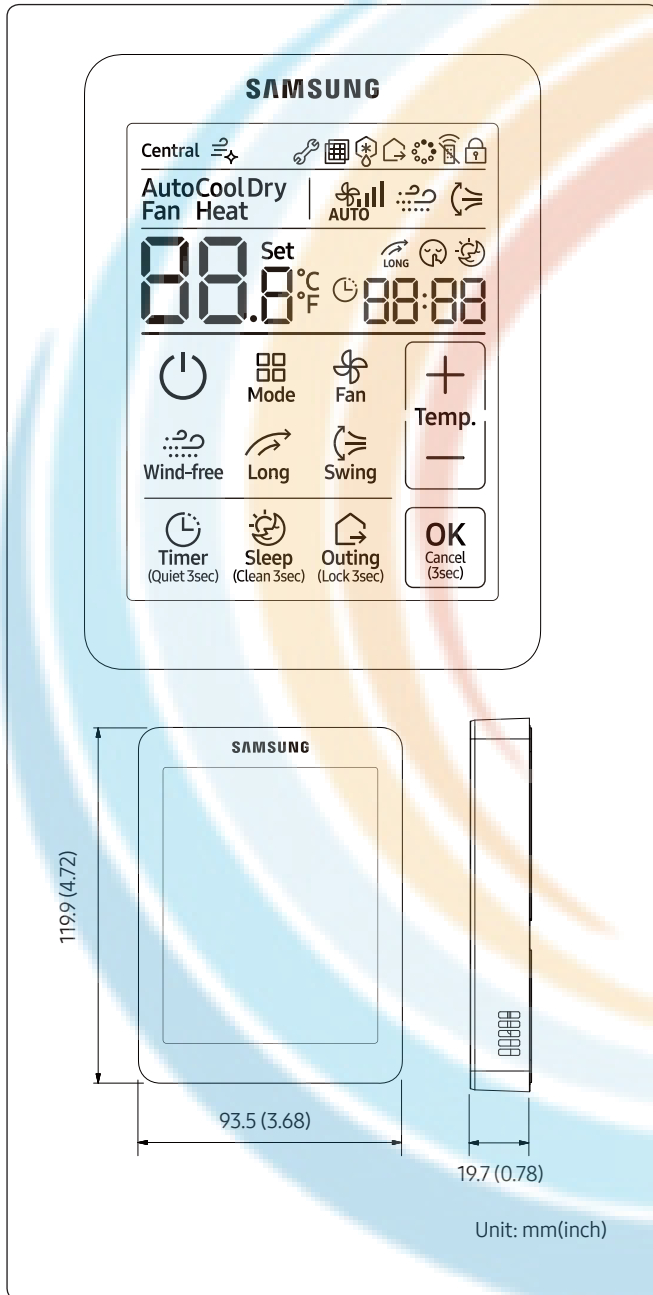

Features

- Touch screen wired remote controller
 - IR wireless signal receiver is included
 - Quiet, Sleep, Outing mode
 - AC operation ON/OFF control
 - Fan speed control
 - Setting operation mode and temperature
 - Reset filter cleaning alert indicator
 - Operation on/off timer function
- * Clean/Wind-Free/Long reach operation

Product specification

Power supply	DC12V
Power consumption	1.5 W
Operating temperature range	0°C~40°C (32°F~104°F)
Operating humidity range	30 % RH~90 % RH
Communication	2-wire PLC
Maximum length of connection	100 m (328ft)
Maximum number of controllable devices	16 indoor units

Compatible product

Indoor unit	AM****N*****Model
	AC****N*****Model

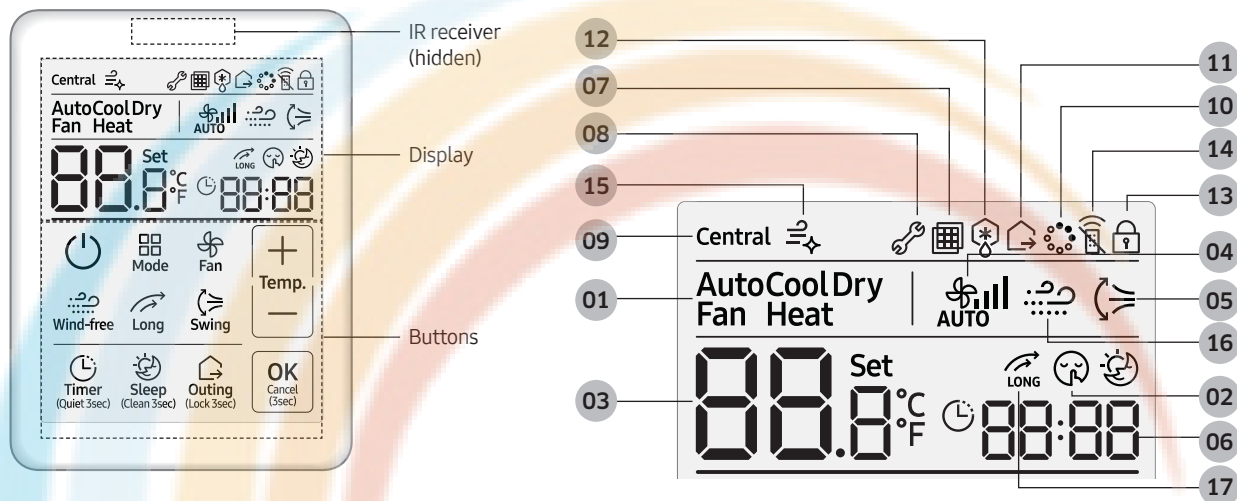

Wired Remote Controller > MWR-SH11UN

Description of parts









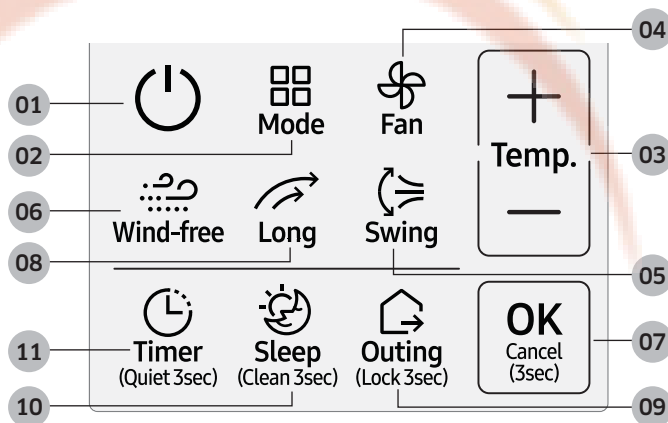
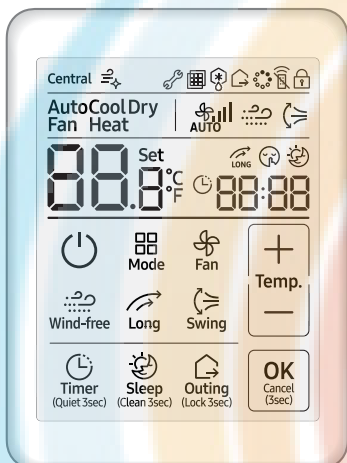



No.	Indication	Description
01	Auto Cool Dry Fan Heat	Displays air conditioner operation.
02		Displays quiet operation.
03		Displays Indoor temperature/Set temperature.
04		Displays AC fan speed.
05		Displays air swing (Up/Down).
06		Displays ON/OFF time (scheduled time).
07		Displays filter cleaning (filter cleaning period).
08		Displays check.
09	Central	Displays centralized control.
10		Displays S-Plasma Ion operation.
11		Displays outing mode.
12		Displays defrost operation.
13		Displays partial locking/all locking/invalid operation.
14		Displays IR receiver for wireless remote controller. (Default : disuse, indication on)
15		Displays Clean operation.

Wired Remote Controller > MWR-SH11UN

No.	Indication	Description
16		Displays Wind-Free Cooling operation.
17		Displays Long reach operation.



No.	Button	Description	
01		Operation on/off button	Turn the air conditioner power on/off
02		Mode button	Select a desired air conditioner operation
03		Temperature setting button	Set a desired temperature and adjust the time
04		Fan speed button	Change the air conditioner's fan speed
05		Air swing button	Select the air flow direction of the air conditioner
06		Wind-Free button	Select Wind-Free Cooling operation
07		OK/Cancel button	Confirm or cancel (by pressing and holding the button for 3 seconds)
08		Long button	Select Long reach function
09		Outing/Lock button	Select outing operation for the air conditioner/Lock the wired remote controller
10		Sleep/Clean button	Select sleep/Clean operation for the air conditioner
11		Timer/Quiet button	Select the timer function/quiet operation for the air conditioner

Wired Remote Controller > MWR-SH11UN

Option function

User setting mode

How to set

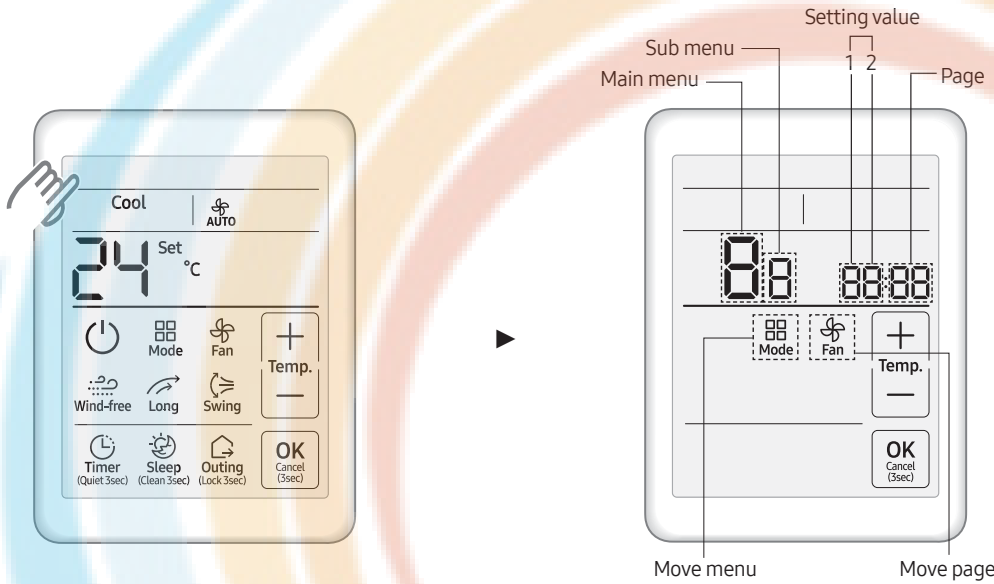

- 1 If you want to use the various additional user functions for your wired remote controller, press the top left corner (hidden button) of the display for more than 3 seconds.
 - You will enter the additional function settings, and the main menu will be displayed.
- 2 Refer to the list of additional user functions for your wired remote controller on the next page, and select the desired menu.
 - Using the [+]/[-] buttons, select a main menu number and press the [Mode] button to enter the sub menu setting screen.
 - Using the [+]/[-] buttons, select a sub menu number and press the [Mode] button to enter data setting screen.
 - Using the [+]/[-] buttons, select the settings.
 - Press the [Fan] button to select page.
 - Press the [OK] button to save the current settings. The [OK] button is invalid on the main menu or sub manu setting screen.
 - Press the [Cancel] button for more than 3 seconds to exit to normal mode without saving settings.

Main menu	Sub menu	Function description	Setting value		Page	Save location	
			Value	Factory default			
2	1	Temperature Limit	Lower limit	8 ~ 30 °C (47 ~ 86 °F)	8 (47)	1	Wired remote controller
	2		Upper limit	8 ~ 30 °C (47 ~ 86 °F)	30 (86)	1	Wired remote controller
	3	Set Outing Temperature	Cooling desire temperature on outing function	25 ~ 30 °C (77 ~ 86 °F)	27 (81)	1	Wired remote controller
	4		Heating desire temperature on outing function	16 ~ 22 °C (61 ~ 72 °F)	16 (61)	1	Wired remote controller

Wired Remote Controller > MWR-SH11UN

Main menu	Sub menu	Function description		Setting value		Page	Save location	
				Value	Factory default			
3	1	Lock of all buttons		0-Unlock, 1-Lock	0	1	Wired remote controller	
	2	Partial Button Lock 1	Lock of operation ON/OFF button	0-Unlock, 1-Lock	0	1	Wired remote controller	
			Lock of temperature setting buttons	0-Unlock, 1-Lock	0	2	Wired remote controller	
			Lock of fan speed button	0-Unlock, 1-Lock	0	3	Wired remote controller	
	3	Partial Button Lock 2	Lock of ON/OFF timer function button	0-Unlock, 1-Lock	0	1	Wired remote controller	
			Lock of Swing function button	0-Unlock, 1-Lock	0	2	Wired remote controller	
			Lock of Sleep function button	0-Unlock, 1-Lock	0	3	Wired remote controller	
			Lock of Quiet function button	0-Unlock, 1-Lock	0	4	Wired remote controller	
			Lock of Outing function button	0-Unlock, 1-Lock	0	5	Wired remote controller	
			Lock of Lock function button	0-Unlock, 1-Lock	0	6	Wired remote controller	
			Lock of Wind-Free Cooling function	0-Unlock, 1-Lock	0	7	Wired remote controller	
			Lock of Long reach function	0-Unlock, 1-Lock	0	8	Wired remote controller	
	4	Operation Mode Partial Button Lock	Lock of Clean function	0-Unlock, 1-Lock	0	9	Wired remote controller	
			Lock of operation mode button	0-Unlock, 1-Lock	0	1	Wired remote controller	
			Hide of auto mode	0-Unlock, 1-Lock	0	2	Wired remote controller	
			Hide of cool mode	0-Unlock, 1-Lock	0	3	Wired remote controller	
			Hide of dry mode	0-Unlock, 1-Lock	0	4	Wired remote controller	
			Hide of fan mode	0-Unlock, 1-Lock	0	5	Wired remote controller	
	6	1	Checking/setting of backlight time out		0~30 (0-Disuse)	5	1	Wired remote controller (1 time use)
			Resetting filter cleaning alarm		0-No reset, 1-Reset	0	1	Wired remote controller
7	User Setting Function	Use of S-Plasma Ion		0-Disuse, 1-Use	0	1	Wired remote controller	
		Use display of current temperature		0-Disuse, 1-Use	1	1	Wired remote controller	
		Use of button melody		0-Disuse, 1-Use	1	1	Wired remote controller	
		Use of IR receiver for wireless remote controller1)*		0-Disuse, 1-Use	0	1	Wired remote controller	
		Use of Standby Mode		0-Disuse, 1-Use	1	1	Wired remote controller	
		Use of Indoor Unit Lighting ON/OFF		0-Unlock, 1-Lock	1	1	Wired remote controller	
		Use of IR receiver for wireless remote controller1)*		0-Disuse, 1-Use	0	1	Wired remote controller	
8	1	Setting/Checking Easy Tuning		-2 ~ +2	0	1	Wired remote controller (1 time use)	
0	1	Reset to default value of user setting mode (except current time)		0-No reset, 1-Reset	0	1	Wired remote controller (1 time use)	

 Note

-  will blink if you select a function that is not supported by the indoor unit.

1)* In case of duct type indoor unit, you can use wireless remote controller using IR receiver of this wired remote controller without "Display and receiver kit". Some functions may not be activated by the wireless remote controller.

Wired Remote Controller > MWR-SH11UN

Example of locking Power button and unlocking Mode button



- 1** Press the top left corner (hidden button) of display for more than 3 seconds to enter to User Setting Mode.
- 2** Main menu segment will display as number 2 and blink in 1 second period when accessed to User Setting Mode.
- 3** Set the Main menu as number 3 by pressing [+]/[-] button.
- 4** Select Sub menu by pressing [Mode] button.
 - Sub menu will be displayed.
- 5** Set the Sub menu as number 2 by pressing [+]/[-] button.
- 6** Select Data by pressing [Mode] button.
 - Page of current menu and data applied to the page will be displayed.
- 7** Set data as number 1 by pressing [+]/[-] button.
- 8** Select Page as number 2 by pressing [Fan] button.
- 9** Set data of page 2 as number 0 by pressing [+]/[-] button.
- 10** Save the current setting by pressing [OK] button.
 - Mode will be changed to normal status without saving current settings by pressing and holding [Cancel] button for more than 3 seconds.

Wired Remote Controller > MWR-SH11UN

Initializing your wired remote controller communication

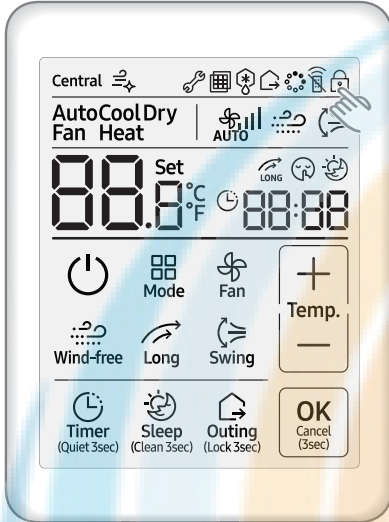

If the number of indoor unit is decreased while you are using your remote control to control one indoor unit or a group of indoor units, then you need to initialize your remote controller communication.

Press the top right corner (hidden button) of the display for more than 7 seconds.

- Your wired remote controller will be initialized, and the device will search for the indoor units connected to your wired remote controller again.

Errors displayed on your wired remote controller



LCD Display

Error codes for the wired remote controller and the indoor units connected to your wired remote controller will be displayed in the LCD display.

When an error occurs in your indoor/outdoor units (product group display : A)

- The product address for the error will be displayed, followed by the error code.
Example : Error101 occurs for Indoor Unit no.10 (decimal digits)

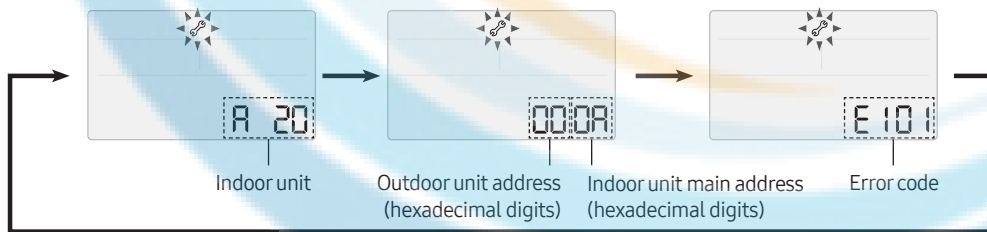

When an error occurs in your wired remote controller

- Only an error code will be displayed. (No address will be displayed.)
Example : Error 601 has occurred at your wired remote controller.



Wired Remote Controller › MWR-SH11UN

Wired remote controller error codes

Display	Description
601	Communication error between wired remote controller and indoor units (When communication is lost for over 3 minutes after detecting the indoor unit and the wired remote controller)
602	No communication between Master(Main) and Slave(Sub) wired remote controllers
604	No communication between wired remote controller and indoor units (Including communication error between indoor units and outdoor units)
618	<ul style="list-style-type: none"> Exceeded maximum number of indoor unit connection (16 indoor units) Reset is required after checking the number of indoor units
627	Two or more wired remote controllers set as slave(sub)
653	Temperature sensor open/short error
654	EEPROM error

Caution

- For the error codes for your indoor/outdoor units, refer to the installation manual of each device.

Wired Remote Controller > MWR-SH11UN

Communication diagram

Individual control with your wired remote controller

Individual control means that you are using one remote controller to control one indoor unit.

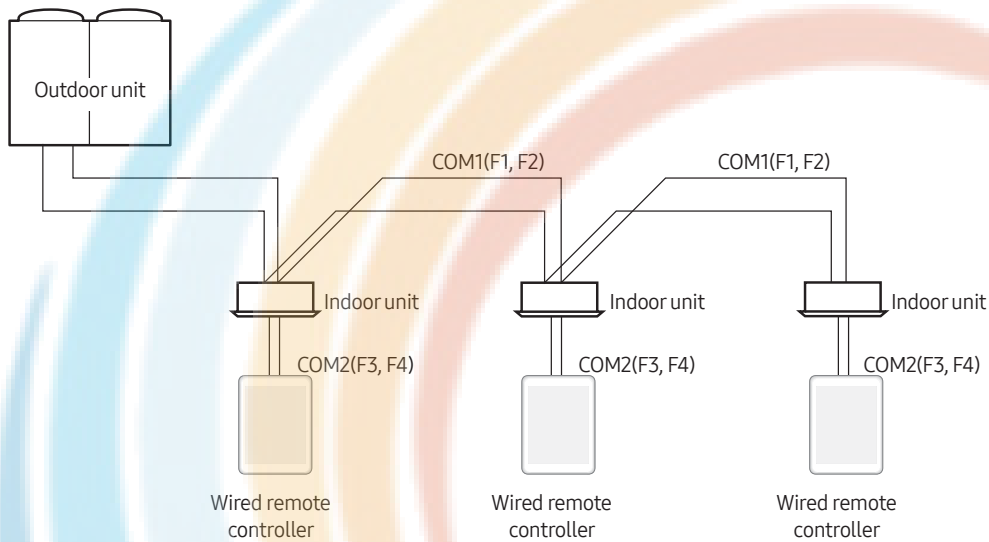

⚠ Caution

- Regardless of the indoor group address (RMC address) only the indoor unit connected to COM2 is individually controlled.

Wired Remote Controller > MWR-SH11UN

Group control with your wired remote controller

Group control means that you are using one wired remote controller to control two or more indoor units at the same time.

1 Using one wired remote controller to control three indoor Units

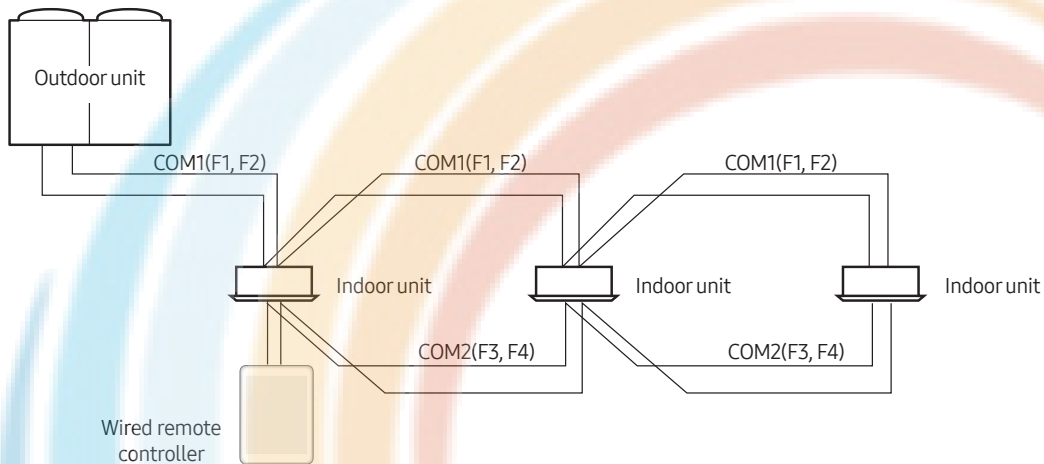

2 Using one wired remote controller to control indoor units connected to different outdoor unit

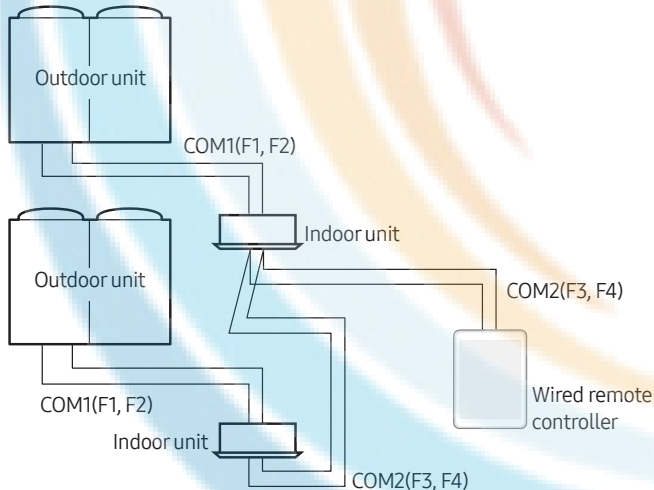

⚠ Caution

- Regardless of the indoor unit's group address (RMC address), only the indoor units connected to COM2 are controlled in group.
- Regardless of your outdoor units, you can control a maximum of 16 indoor units as a group.
- When controlling group of indoor units connected to different outdoor unit, address of the each outdoor unit must be set differently.

Wired Remote Controller > MWR-SH11UN

Controlling 2-Remote controller

2-Remote controller is controlling one indoor unit or a group of indoor units with two remote controllers.

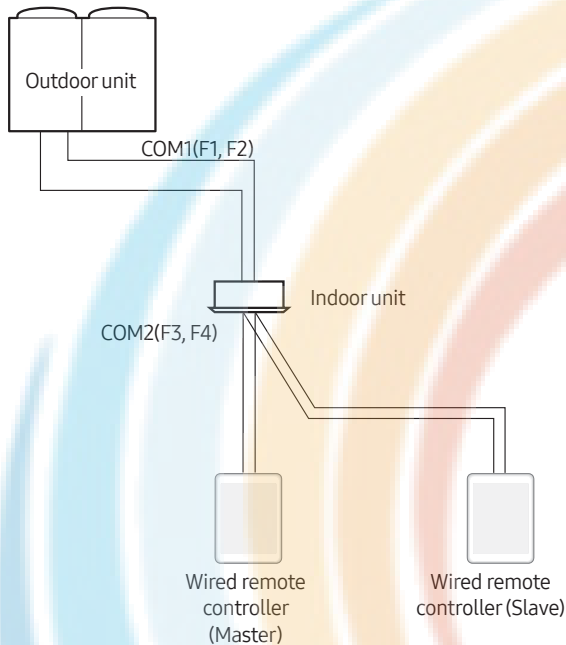

⚠ Caution

- For the slave wired remote controller settings, please refer to the sections about the additional functions of the wired remote controller. (Refer to 'Additional Functions of your wired remote controller' main menu 1 → sub menu 1, master/slave setting)
- You can only use several functions on the master setting.
 - On-off timer
 - Outing
 - Easy tuning
 - Displays the total number of indoor units
- Adjust temperature and select mode when relative temperature is displayed

📄 Note

- Wired remote controller without a master/slave setting is properly connected, but if you need to set a specific wired remote controller as a master, you have to set master/slave in the service mode 1-1.

Receiver KIT

MRK-A10N

Features

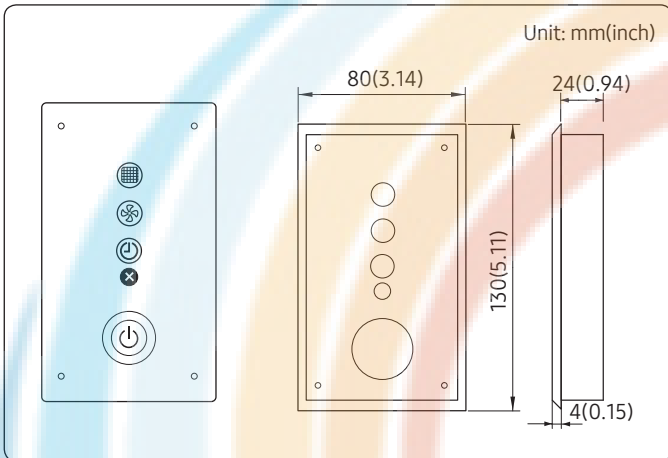

Receiver & Display Unit

- Wireless signal receiver
- Filter replacement sign
- Fan operation display
- Operation Timer setting display
- Operation On/Off button
- Operation On display LED (blue)
- Defrost operation display LED (red)

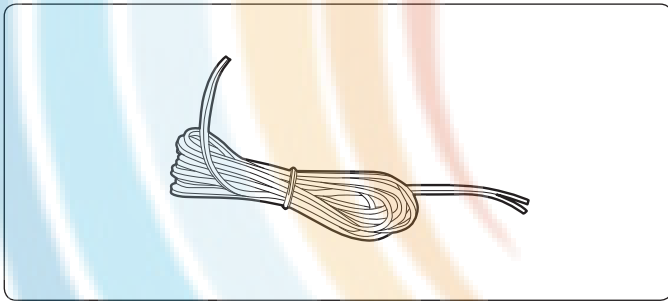

- Receiver wire

Wiring

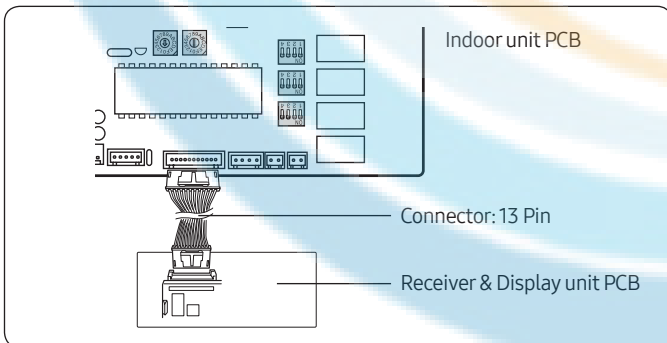

- Connect one end of the receiver wire with the Receiver & Display unit PCB.
- Connect the other end of the receiver wire with the duct type indoor unit PCB.

Note

- Wire length: 10m (32.80ft)
- Receiver & Display unit is only available for a duct type indoor unit.

Chapter
02

Centralized Control System

OnOff controller

MCM-A202DUN.....67

Touch centralized controller

MCM-A300UN.....74

Wi-Fi kit

MIM-H03UN.....87

Module Controller

MCM-A00UN101

OnOff controller

MCM-A202DUN

Features

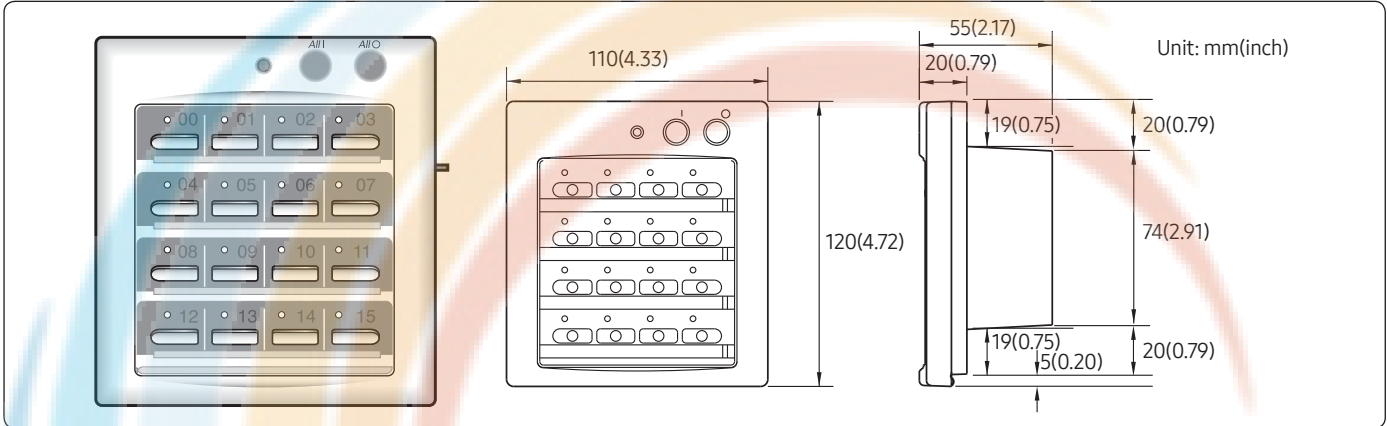

- Maximum 16-group controller (Max. 128 units)
- Whole/Group/Individual indoor unit control (On/Off)
- Restriction on the use of wireless/wired remote controllers and external contact control
- Cooling and heating mode control
- Indoor unit error display

Product specification

Power supply	AC100~240V, 50/60Hz											
Power consumption	8W											
Operating Temperature range	0°C~40°C (32°F~104°F)											
Operating Humidity range	30%RH~90%RH											
Communication	RS485 x 1 (R1/R2, F1/F2)											
Max. Communication length	1000M (3280ft)											
Max. connectable number of device	Set layer	<table border="1"> <thead> <tr> <th>Device</th> <th>Number</th> </tr> </thead> <tbody> <tr> <td>Indoor units (including ERV, MCU)</td> <td>80 (Maximum 64 indoor units, 16 ERVs and 15 MCUs)</td> </tr> <tr> <td>Outdoor unit</td> <td>1</td> </tr> <tr> <td>OnOff controller/Touch centralized controller/Wi-Fi kit</td> <td>Total 16</td> </tr> </tbody> </table>	Device	Number	Indoor units (including ERV, MCU)	80 (Maximum 64 indoor units, 16 ERVs and 15 MCUs)	Outdoor unit	1	OnOff controller/Touch centralized controller/Wi-Fi kit	Total 16		
		Device	Number									
		Indoor units (including ERV, MCU)	80 (Maximum 64 indoor units, 16 ERVs and 15 MCUs)									
		Outdoor unit	1									
	OnOff controller/Touch centralized controller/Wi-Fi kit	Total 16										
	Control layer	<table border="1"> <thead> <tr> <th>Device</th> <th>Number</th> </tr> </thead> <tbody> <tr> <td>Indoor units (including ERV, MCU)</td> <td>128</td> </tr> <tr> <td>Outdoor unit (including compatible interface module MIM-N01)</td> <td>16</td> </tr> <tr> <td>OnOff controller/Touch centralized controller</td> <td>16 (15 when DMS2.5, BACnet gateway, LonWorks gateway is connected)</td> </tr> <tr> <td>DMS2.5/BACnet GW/LonWorks GW</td> <td>Total 1</td> </tr> </tbody> </table>	Device	Number	Indoor units (including ERV, MCU)	128	Outdoor unit (including compatible interface module MIM-N01)	16	OnOff controller/Touch centralized controller	16 (15 when DMS2.5, BACnet gateway, LonWorks gateway is connected)	DMS2.5/BACnet GW/LonWorks GW	Total 1
		Device	Number									
		Indoor units (including ERV, MCU)	128									
Outdoor unit (including compatible interface module MIM-N01)		16										
OnOff controller/Touch centralized controller	16 (15 when DMS2.5, BACnet gateway, LonWorks gateway is connected)											
DMS2.5/BACnet GW/LonWorks GW	Total 1											

OnOff controller > MCM-A202DUN

Compatible product

Outdoor unit	AM*****X*****
Controller	OnOff controller (MCM-A202DUN)
	Touch centralized controller (MCM-A300UN)
	DMS2.5 (MIM-D01AUN)
	BACnet GW (MIM-B17BUN)
	LonWorks GW (MIM-B18BUN)

- Conventional communication outdoor unit requires interface module (MIM-N01) to establish connection
- MIM-B13D, MIM-B13E, MIM-B04A Interface modules cannot be connected.
- To connect ERV, MIM-N10 interface module is required.

Description of parts

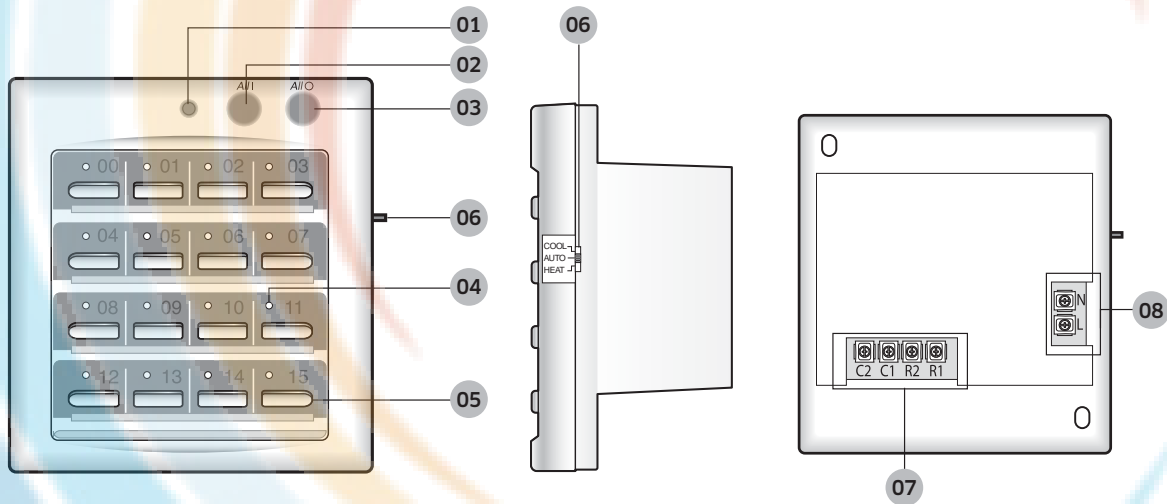

No.	Name	Description
01	Indoor unit operation LED	<ul style="list-style-type: none"> • It lights on when more than one indoor unit operates. • It flickers during indoor unit tracking process after power reset.
02	All ON button	Press All ON button to turn on all the indoor units.
03	All OFF button	Press All OFF button to turn off all the indoor units.
04	Group indoor unit operation LED	<ul style="list-style-type: none"> • It lights on when one indoor unit of the group is operating. • It also flickers when indoor unit has an error. • During tracking indoor units, LED whose number is equivalent to indoor unit RMC(2) address flickers.
05	Indoor unit control button	Press indoor unit of the group button to control the equivalent unit operation.

OnOff controller > MCM-A202DUN

No.	Name	Description
06	Operation mode selection switch	Set operation mode selection switch to a certain mode and press indoor unit control button to control operation mode. Whenever pressing any button on the controller, set operation mode is delivered to the indoor unit.
07	Communication terminal	<ul style="list-style-type: none"> C1 C2: No function R1 R2: Connect to Outdoor unit, DMS2.5, OnOff controller
08	Power terminal	AC100V~240V connection

Note

- Press button 11 and button 15 together for 5 seconds to reset the OnOff controller.

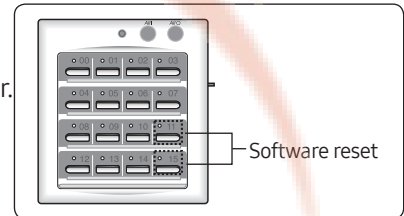

Different Levels of the OnOff Controller

- Adjust the DIP switch in the OnOff controller PCB and set a level. This will enable the user to control the indoor units connected to the OnOff controller according to the set level.

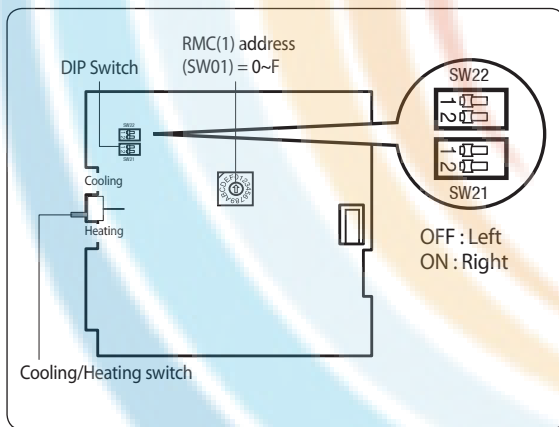

Switch No.	SW22		Meaning
	1	2	
LEVEL 0	OFF	OFF	Among the various controllers, such as the OnOff controller, wired/wireless controller and the indoor unit button, the air conditioner will only be able to operate with the most recently used controller
LEVEL 1	ON	OFF	The wired/wireless controller can only be used when the OnOff controller is powered on.
LEVEL 2	OFF	ON	The air conditioner can only be operated with the OnOff controller.

Note

- The LEVEL of the OnOff controller is '0' when all the switches are in the 'OFF' position.
 - Changed LEVEL will be applied immediately when you turn on or off the operation with an OnOff controller.
 - Level application and authorization for controlling from OnOff controller can be restricted depending on the Level setting from the upper controller with priority.
- Ex) OnOff controller cannot control the indoor units if the control level set from the DMS is higher than the level of OnOff controller.

OnOff controller > MCM-A202DUN

Setting the option for OnOff controller

1 You can adjust the DIP switch (SW21) on PCB of the OnOff controller to set the option and control the OnOff controller according to the selected option.

SW21		Contents
1	2	
ON	-	Disable OnOff controller usage
OFF	-	Enable OnOff controller usage

- All the DIP switches of the OnOff controller is set to OFF as factory default setting.
- SW21 setting of the DIP switch will be applied instantly.
- Option setting for communication can be executed regardless of the Level setting.

Connection diagram

Set layer connection (F1/F2)

- When OnOff controller only controls indoor units of 1 outdoor unit, then it can be connected to F1/F2 line of outdoor unit or indoor unit.
- Max. 16 Controllers can be connected to same communication line.

⚠ Caution

- Connectable controller: OnOff controller (MCM-A202DUN), Touch centralized controller (MCM-A300UN), Wi-Fi kit (MIM-H03UN)

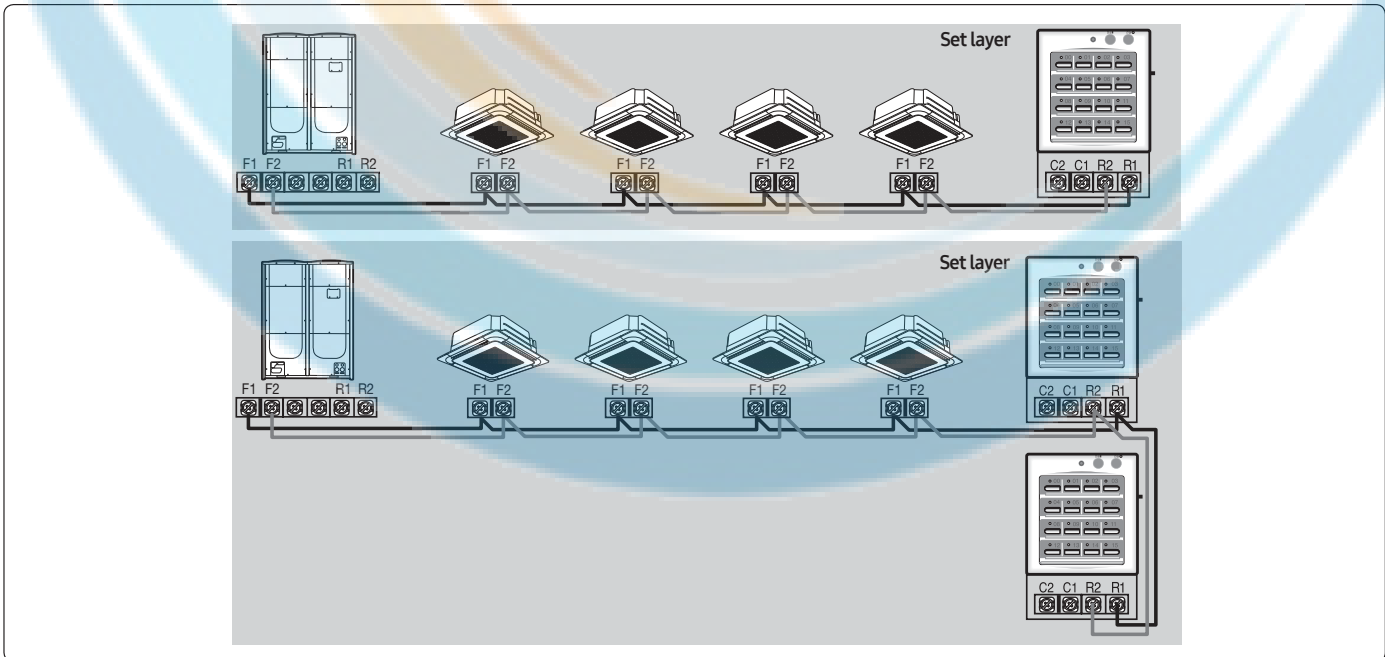

OnOff controller > MCM-A202DUN

Control layer connection (R1/R2)

- New communication upper level controller
- Max. 16 Controllers can be connected to same communication line (In case of DMS2.5/BACnet gateway/LonWorks gateway connection, Max.15)
- Max. 16 outdoor units can be connected to same communication line (Includes interface module MIM-N01).

⚠ Caution

- Connectable controller
 - Touch centralized controller (MCM-A300UN).
 - OnOff controller (MCM-A202DUN).
 - DMS2.5(MIM-D01AUN), BACnet gateway (MIM-B17BUN), LonWorks gateway (MIM-B18BUN): Only one of the three models.

Connection with outdoor unit

When OnOff controller controls indoor units of multiple outdoor units, then it should be connected to R1/R2 line of outdoor units.

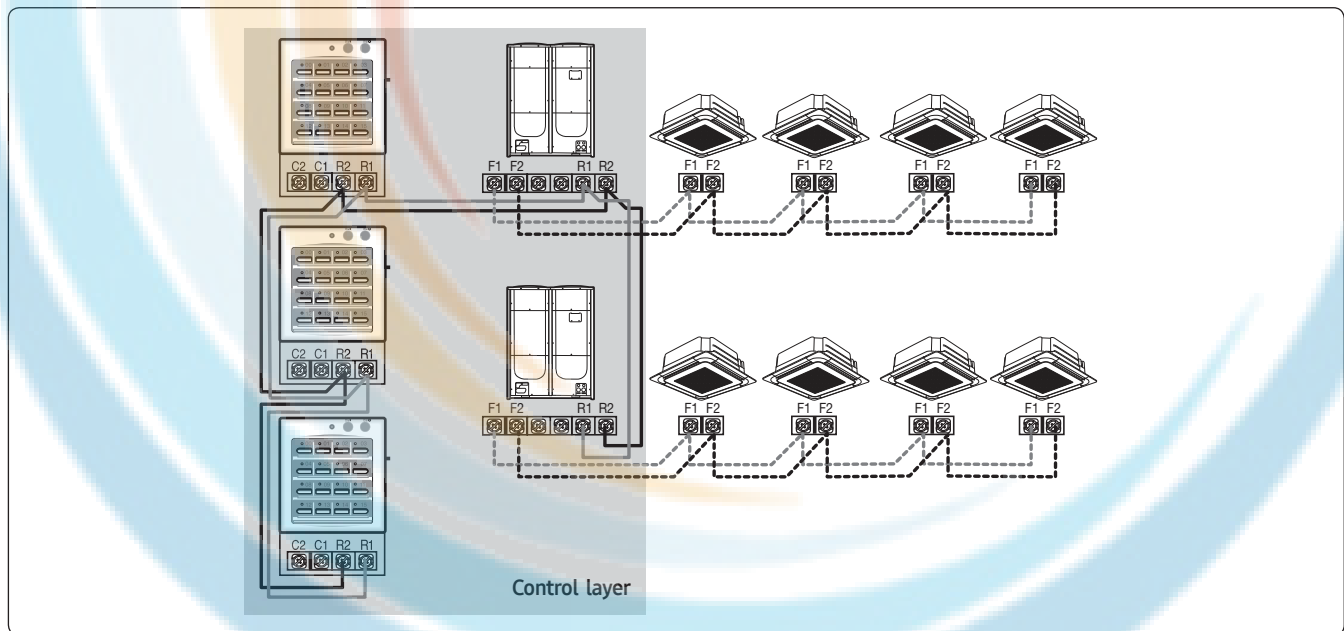

OnOff controller > MCM-A202DUN

Connection with DMS2.5/BACnet GW/LonWorks GW

- Case1

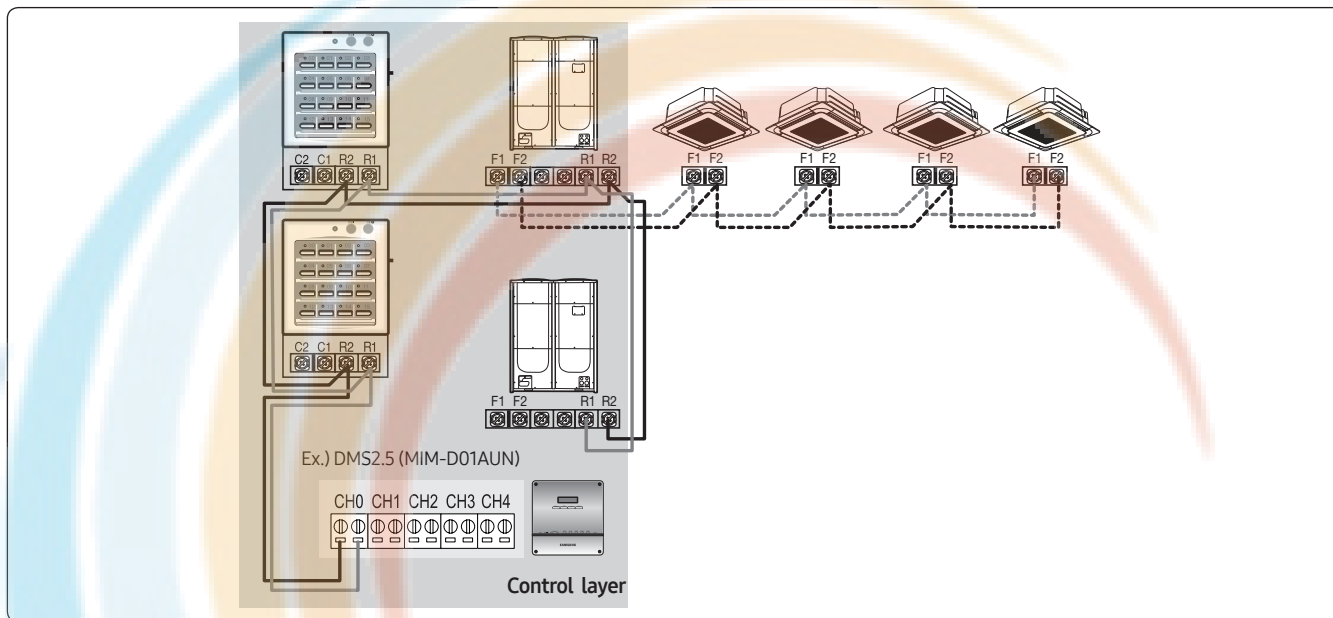

- Case2

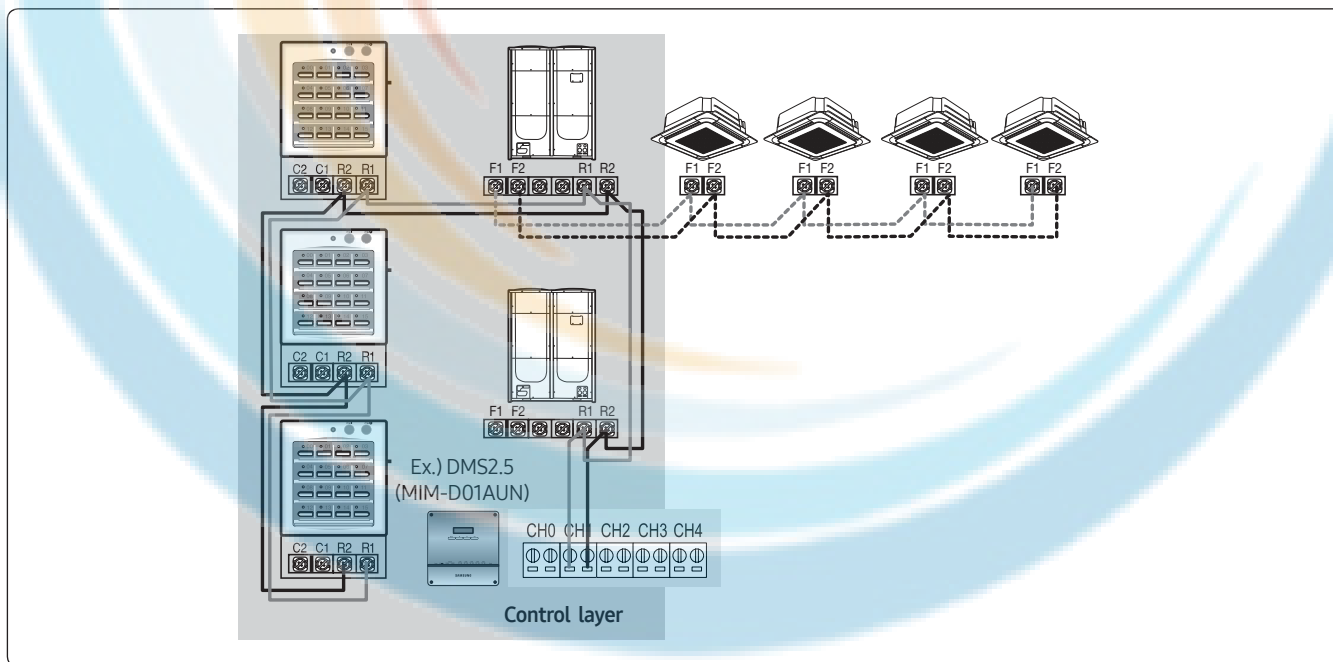

⚠ Caution

- When OnOff controller is connected to Outdoor unit's F1/F2 line, you cannot connect DMS2.5 to OnOff controller's R1/R2 line.

OnOff controller > MCM-A202DUN

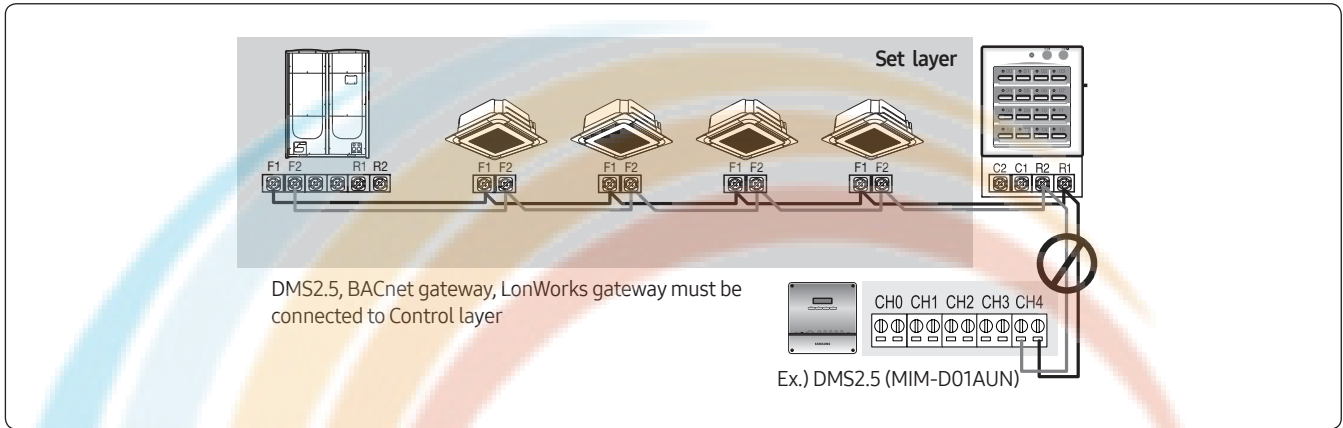

Display

Various LED display

After power reset to the OnOff controller, it carries out indoor unit tracking process.

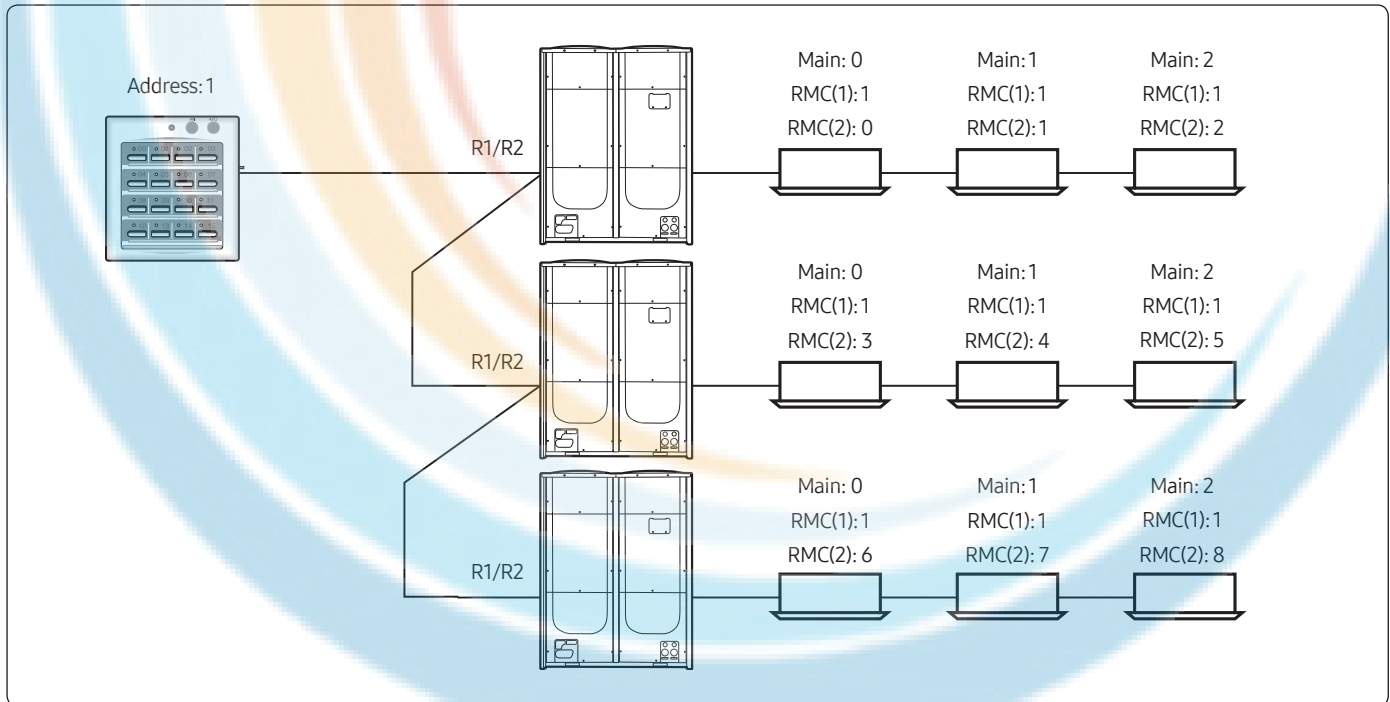

- OnOff controller only communicate with indoor units which has same RMC(1) address with OnOff controller's address.
- During tracking indoor units, LED whose number is equivalent to indoor unit RMC(2) address flickers.
 - In LED 00 → LED 01 → LED 02 → LED 03 → LED 04 → LED 05 order

Touch centralized controller

MCM-A300UN

Features

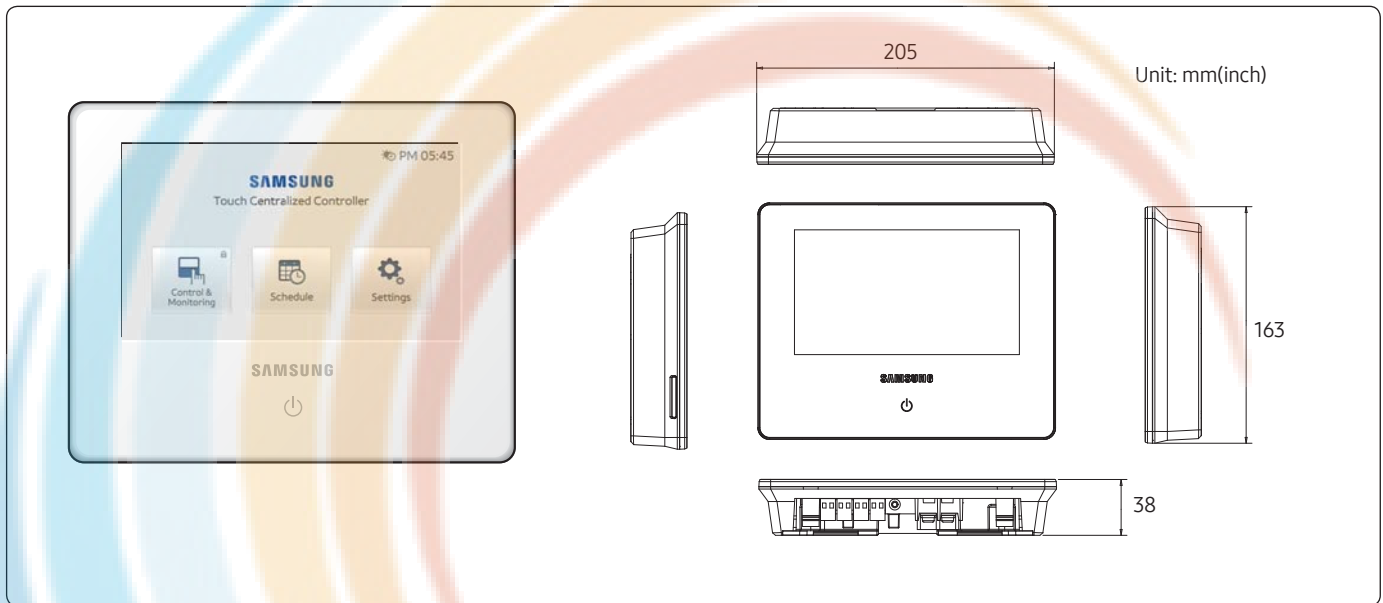

- 7 inch touch LCD controller
- Controls maximum 128 indoor units
- Controls maximum 12 zones
- Schedule control, Indoor unit usage restriction, View indoor unit error history

Touch centralized controller > MCM-A300UN

Product specification

Power supply		AC100~240V, 50/60Hz	
Power consumption		110W	
Operating temperature range		0°C~40°C (14°F~104°F)	
Operating humidity range		30%RH~90%RH	
Communication		RS485 x1 (F1/F2 or R1/R2)	
External communication port	Digital Output	1	
	Digital Input	2	
Maximum connection length	RS485	1000m(3280ft)	
	Digital Output	100m(328ft)	
	Digital Input	100m(328ft)	
Max. connectable number of device	Set layer	Device	Number
		Indoor units (including ERV, MCU)	80 (Maximum 64 indoor units, 16 ERVs and 15 MCUs)
		Outdoor unit	1
		OnOff controller	Total 16
		Touch centralized controller	
		Wi-Fi kit	
	Control layer	Device	Number
		Indoor units (including ERV, MCU, FCU KIT)	128
		Outdoor unit (including MIM-N01, MIM-N10, MIM-F10N, DVM CHILLER unit)	16
		OnOff controller	16 (15 when DMS2.5, BACnet gateway, LonWorks gateway is connected)
		Touch centralized controller	
		DMS2.5	Total 1
		BACnet GW	
		LonWorks GW	
Wi-Fi kit (MIM-H03UN)	Total 1 (Maximum 16 indoor units, 16 outdoor units)		

Touch centralized controller > MCM-A300UN

Compatible product

Outdoor unit	AM****X*****
Controller	OnOff controller (MCM-A202DUN)
	Touch centralized controller (MCM-A300UN)
	DMS2.5 (MIM-D01AUN)
	BACnet gateway (MIM-B17BUN)
	LonWorks gateway (MIM-B18BUN)
	Wi-Fi kit (MIM-H03UN)

- Conventional communication outdoor unit requires interface module (MIM-N01) to establish connection
- MIM-B13D, MIM-B13E, MIM-B04A Interface modules cannot be connected.
- To connect ERV, MIM-N10 is required.
- To connect FCU KIT, MIM-F10N is required.

Description of parts

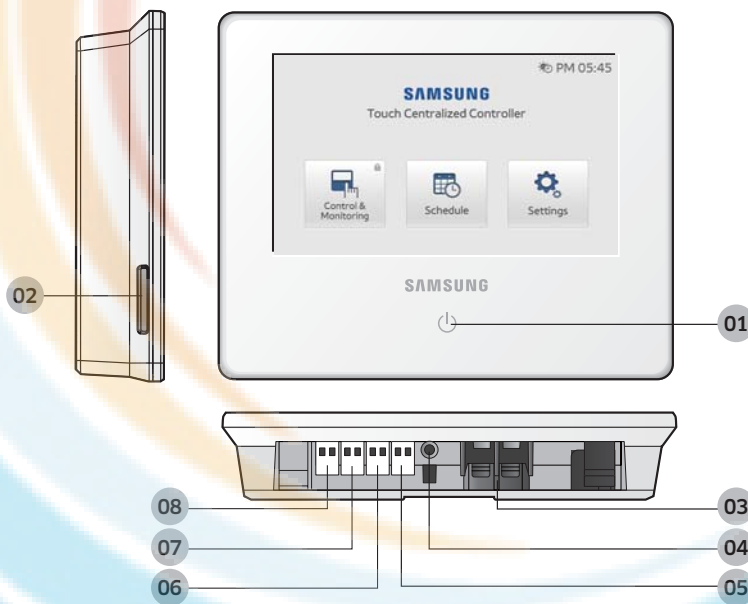

No.	Name	Description
01	LCD On/Off button and Indoor unit operation indicator	<ul style="list-style-type: none"> • Button: Turn on/off the LCD screen • Indicator <ul style="list-style-type: none"> – Blue: Turns on if any one of the indoor unit is in operation. – Red: Turns on if any one of the indoor unit has an error
02	SD card slot	Use to back-up data on SD card or updating software
03	Power terminal	Connect AC 100~240 V, 50/60 Hz power
04	Reset button	Use to reset Touch centralized controller

Touch centralized controller > MCM-A300UN

No.	Name	Description
05	DI-1 terminal	Terminal block for connecting digital input signal from 3rd party device.
06	DI-2 terminal	Terminal block for connecting digital input signal from 3rd party device.
07	DO Terminal	Terminal block for digital output signal. <ul style="list-style-type: none"> • Short: When any one of indoor units turns On • Open: When all indoor units are off
08	485 communication terminal	<ul style="list-style-type: none"> • When connecting to set layer: Connect to outdoor unit or indoor unit (F1/F2) • When connecting to control layer: Connect to outdoor unit, OnOff controller, Touch centralized controller or DMS2.5 (R1/R2)

Connection diagram

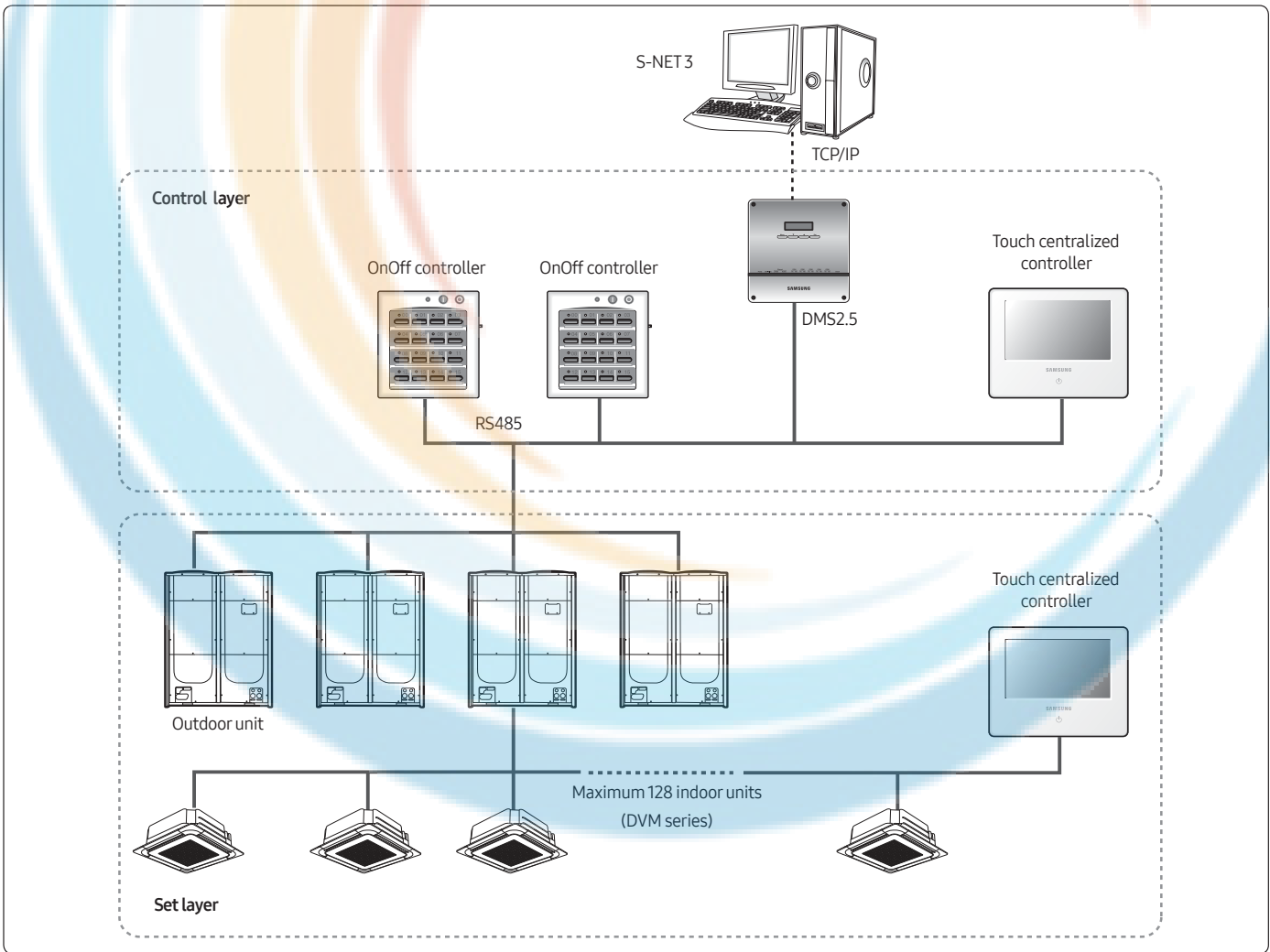

Touch centralized controller > MCM-A300UN

Connection

Set layer connection (F1/F2)

- When Touch centralized controller only controls indoor units of 1 outdoor unit, then it can be connected to F1/F2 line of outdoor unit or indoor unit.
- Max. 16 Controllers can be connected to same communication line.

⚠ Caution

- Connectable controller: OnOff controller (MCM-A202DUN), Touch centralized controller (MCM-A300UN), Wi-Fi kit (MIM-H03UN)

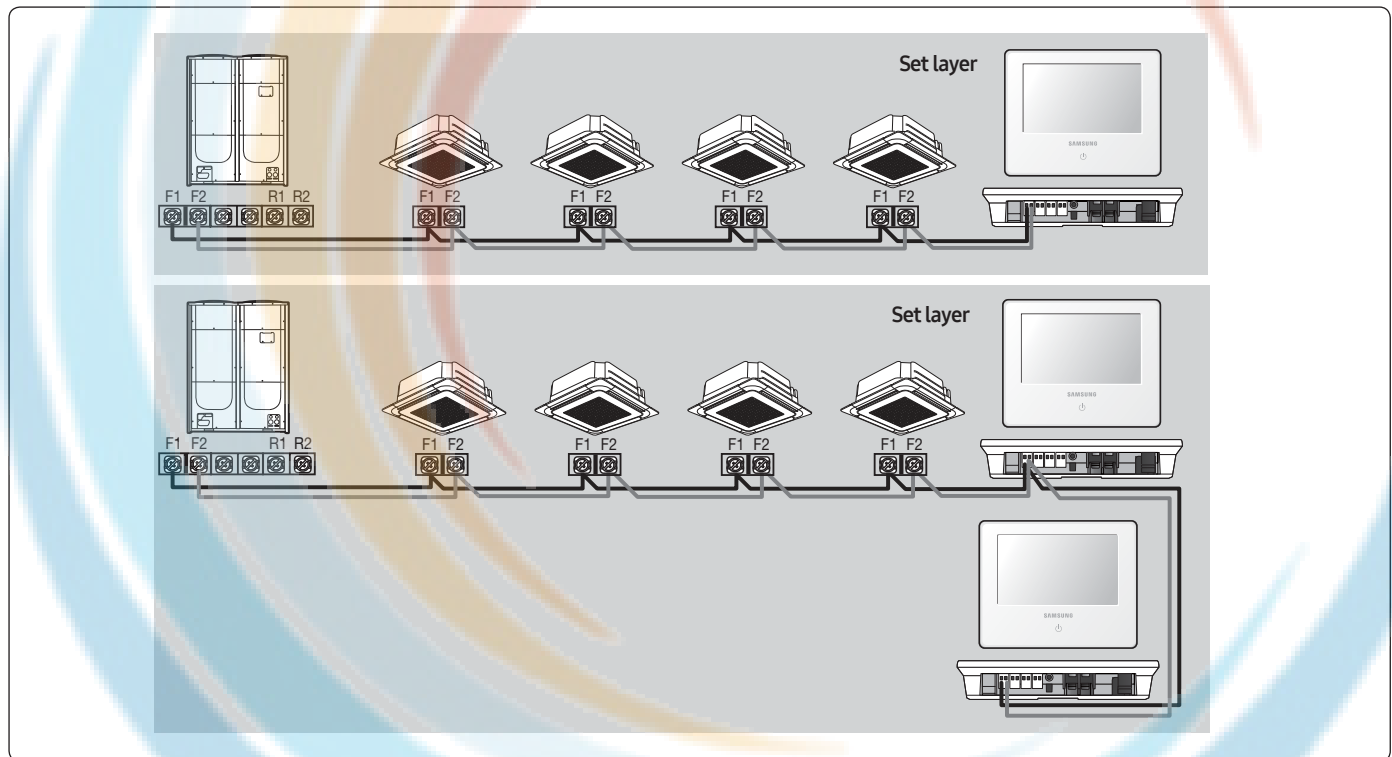

Control layer connection (R1/R2)

- Max. 16 Controllers can be connected to same communication line (In case of DMS2.5/BACnet gateway/LonWorks gateway connection, Max.15)
- Max. 16 outdoor units can be connected to same communication line (Includes interface module MIM-N01).

⚠ Caution

- Connectable controller
 - Touch centralized controller (MCM-A300UN).
 - OnOff controller (MCM-A202DUN).
 - DMS2.5(MIM-D01AUN), BACnet gateway (MIM-B17BUN), LonWorks gateway (MIM-B18BUN): Only one of the three models.

Touch centralized controller > MCM-A300UN

Connection with outdoor unit

When Touch centralized controller controls indoor units of multiple outdoor units, then it should be connected to R1/R2 line of outdoor units.

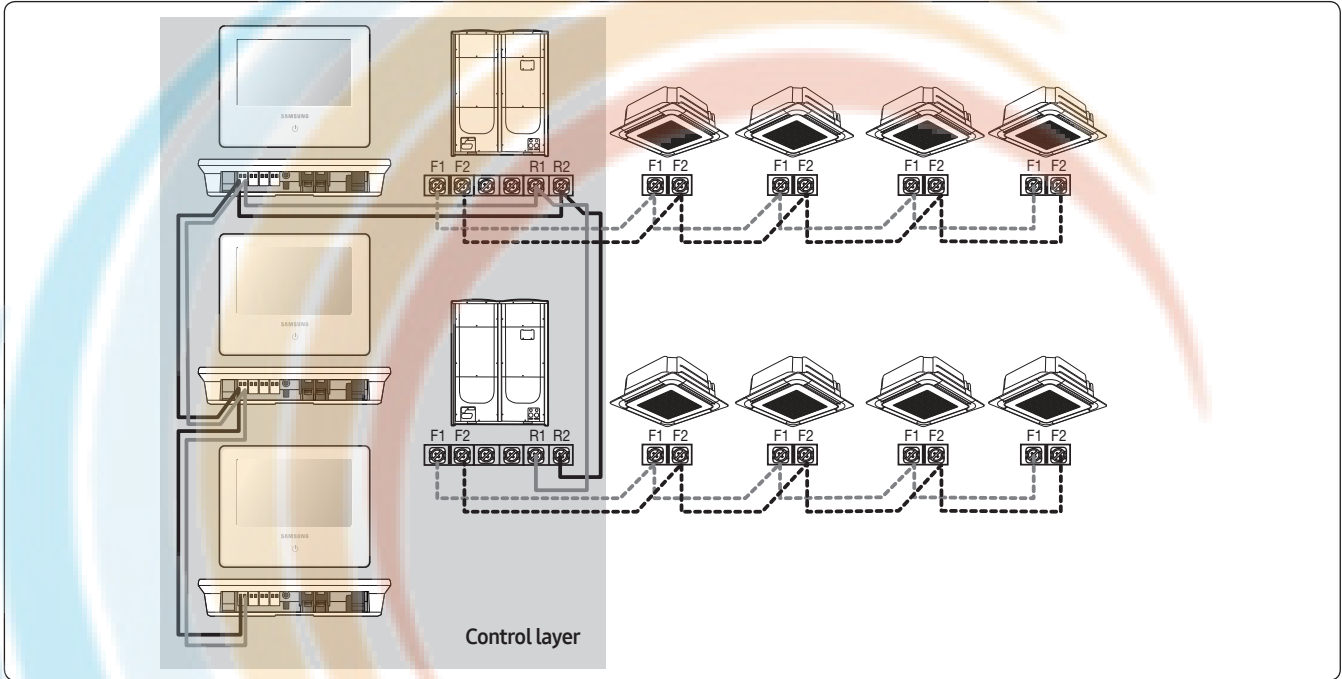

Connection with DMS2.5/BACnet GW/LonWorks GW

- Case1

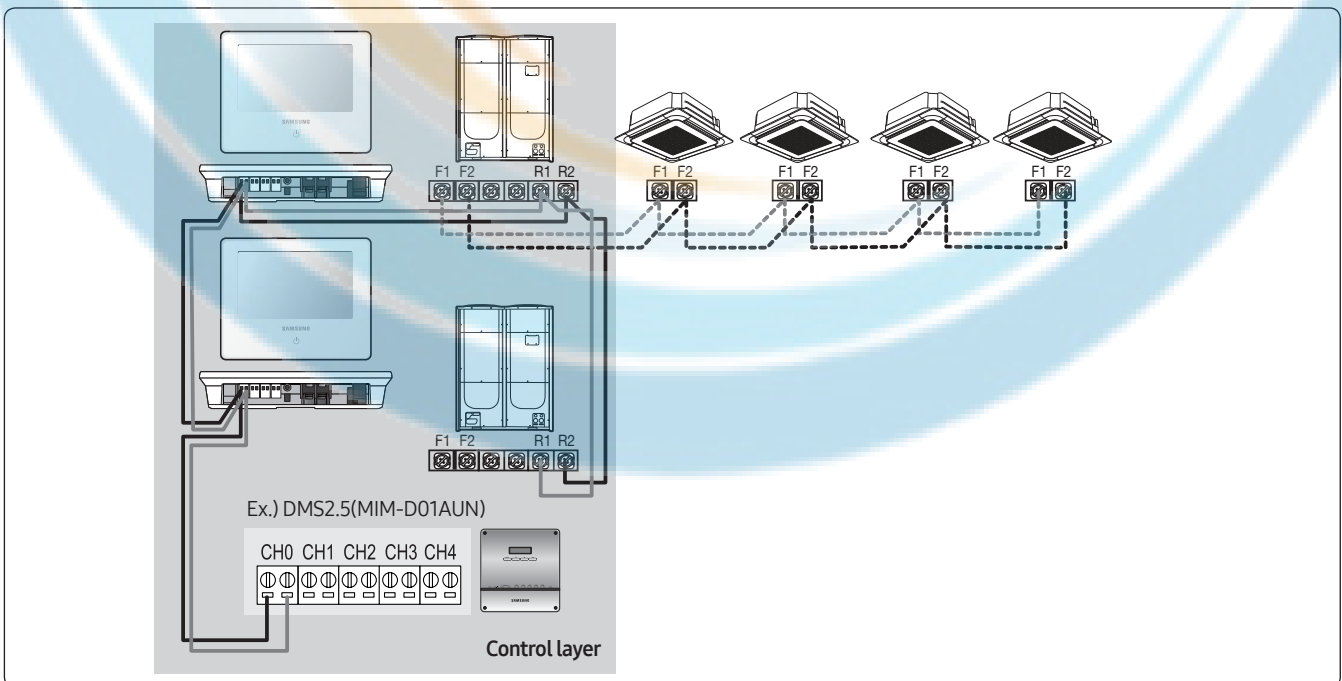

Touch centralized controller > MCM-A300UN

• Case2

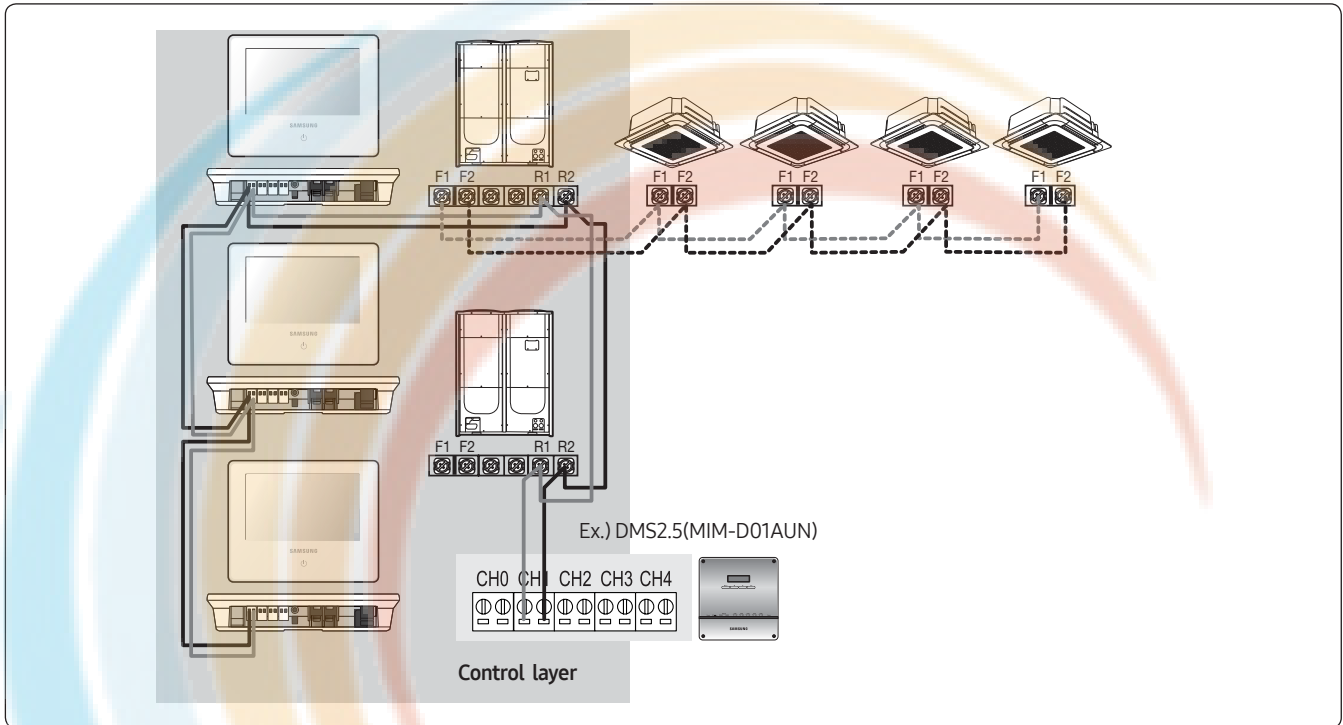

⚠ Caution

- DMS2.5, BACnet GW, and LonWorks GW cannot be connected to F1/F2.

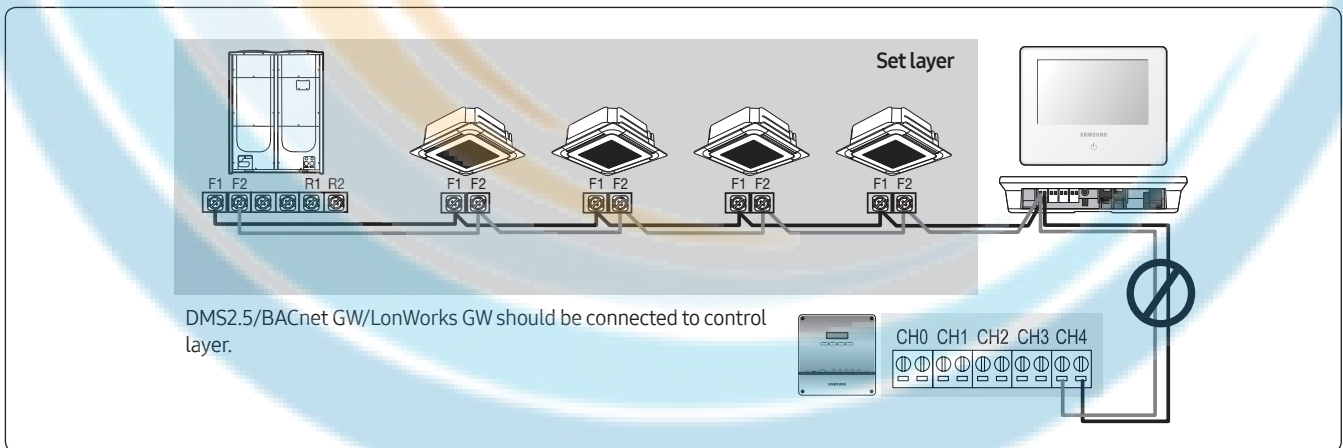

Touch centralized controller > MCM-A300UN

Main function

Zone control



- You can create a zone by grouping multiple indoor units
- Maximum 12 zones can be created (Total up to 128 indoor units)

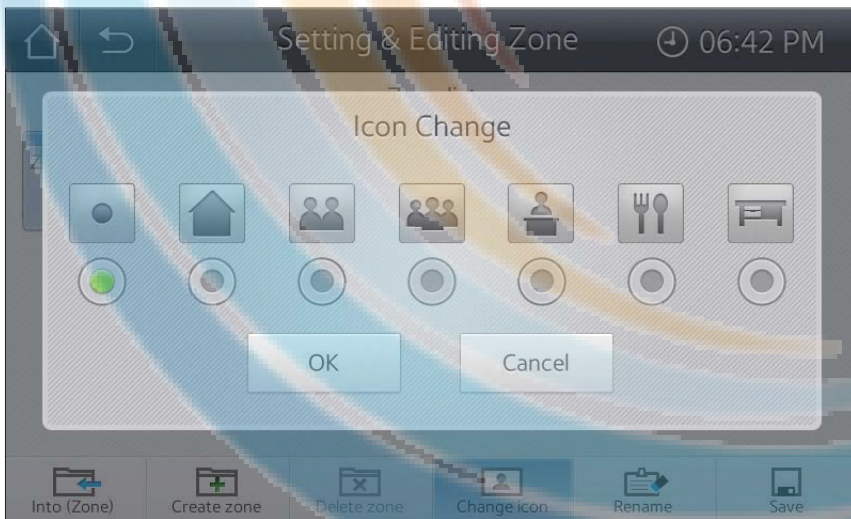

- You can set the name of Zone/indoor unit
- You can set the zone icon for purpose of each zone.

Touch centralized controller > MCM-A300UN

Grouping indoor units

Function to control and monitor multiple indoor units that are grouped and expressed as single indoor unit



Schedule control

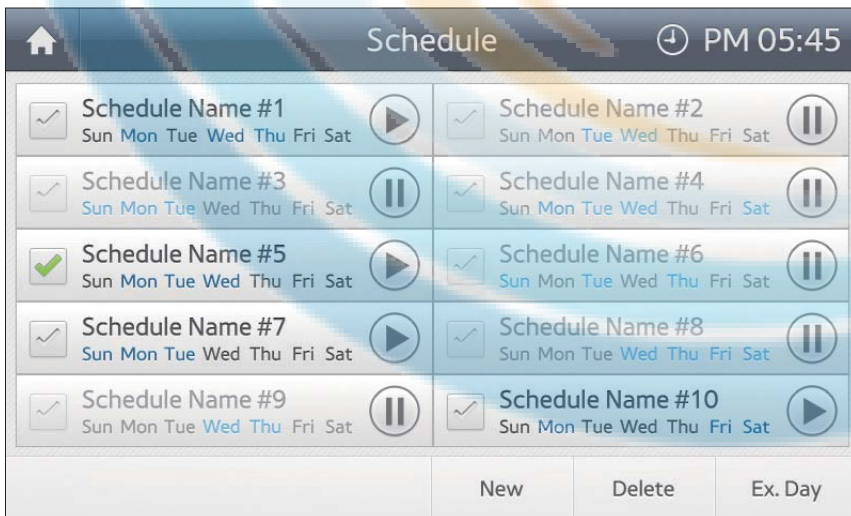

- Maximum 10 schedules can be created
- Excluded day setting is possible

Touch centralized controller > MCM-A300UN

Setting indoor unit usage restriction

Cool lower limit/Heat upper limit

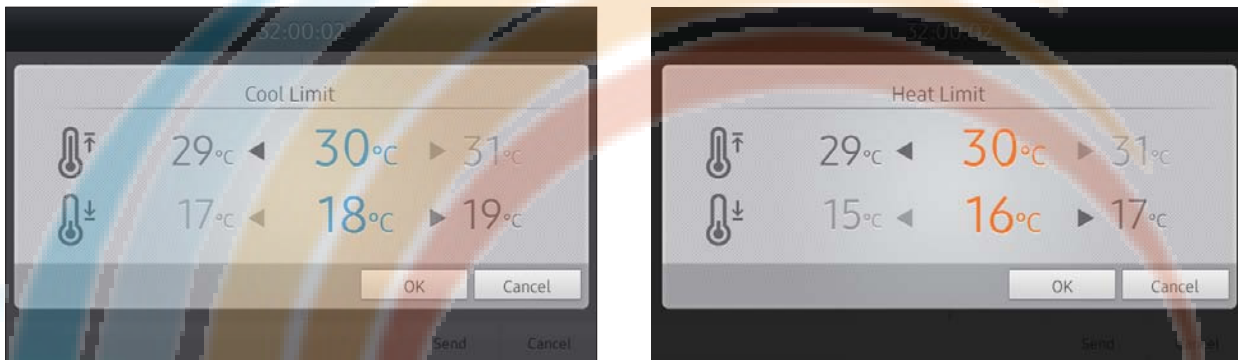

- It can set the temperature limit in Cool mode & Heat mode.
- This setting can be changed by other touch centralized controller and DMS2.5.

Operation mode limit

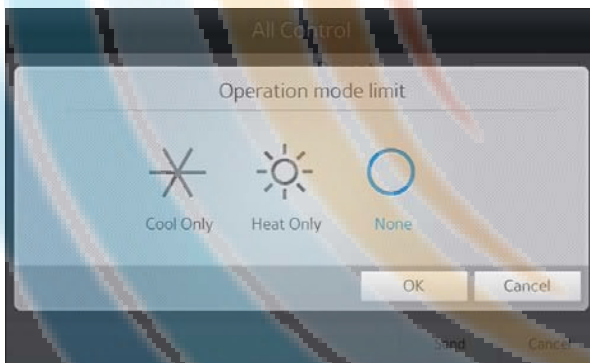

- To prevent the wrong operation mode setting, it can limit the operation mode of indoor unit.
 - Cool only: Heat, Auto (Heat) operation mode is restricted
 - Heat only: Cool, Dry, Auto (Cool) operation mode is restricted
- This setting can be changed by other touch centralized controller and DMS2.5.

Touch centralized controller > MCM-A300UN

Lock function

You can lock the functions of Touch centralized controller.

Screen lock

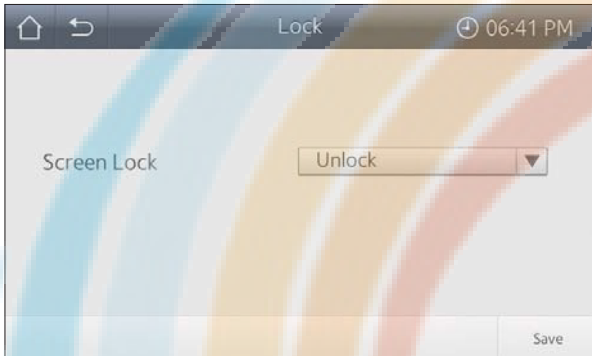

- You can lock the screen. Password is required when you try to use it.

Operating panel lock



- You can set the access lock of each item of operating panel. The locked item will be deactivated.

Menu lock

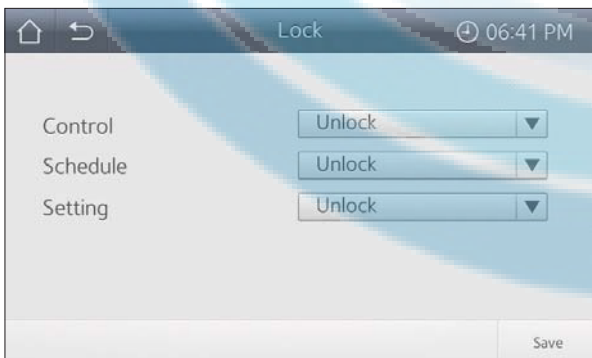

- You can set the access lock of each menu. Password is required when you try to use it.

Touch centralized controller > MCM-A300UN

Remote controller usage restriction

Indoor unit operating panel

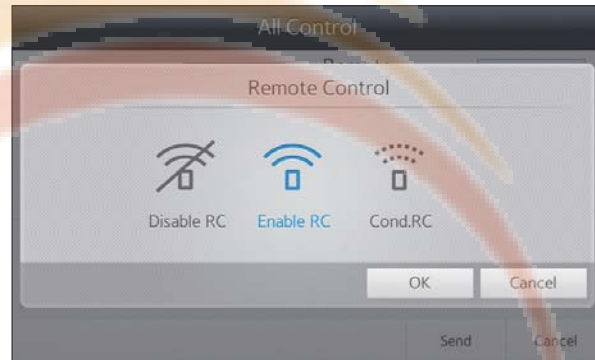

- You can set the controller restriction.
- You can set the type of controller which will be restricted when "Disable RC" is applied from operating panel. [Settings] → [Device settings] → [Control level]

Device settings

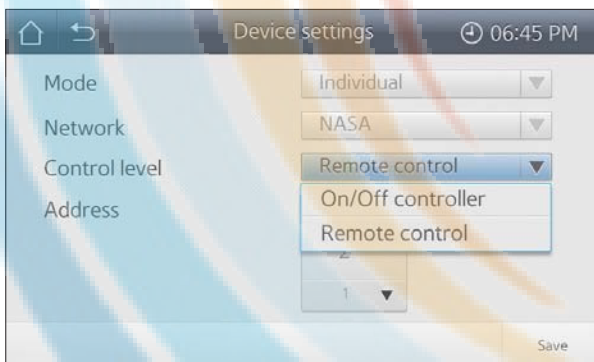

- You can set the type of controller which will be restricted when "Disable RC" is applied from operating panel.
 - Remote controller: Restrict wired/wireless remote controller usage, OnOff controller usage is possible
 - OnOff controller: Restricts wired/wireless remote controller and OnOff controller usage

Touch centralized controller › MCM-A300UN

Tracking

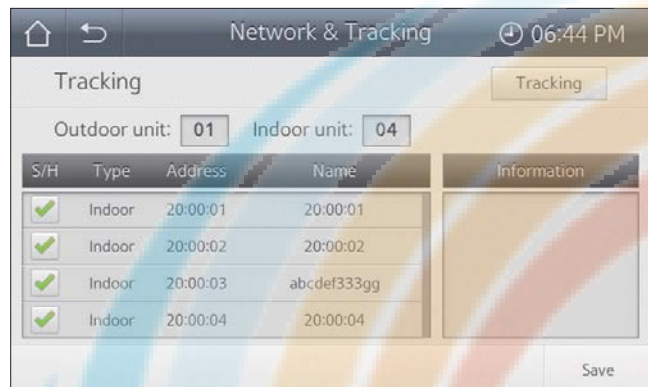

- Detects all the indoor and outdoor units that are connected to communication line of Touch centralized controller
- When multiple number of Touch centralized controller is connected together, you can use check box of S/H (Show/Hide) to select indoor units that will be controlled from each Touch centralized controller.

Hiding indoor unit

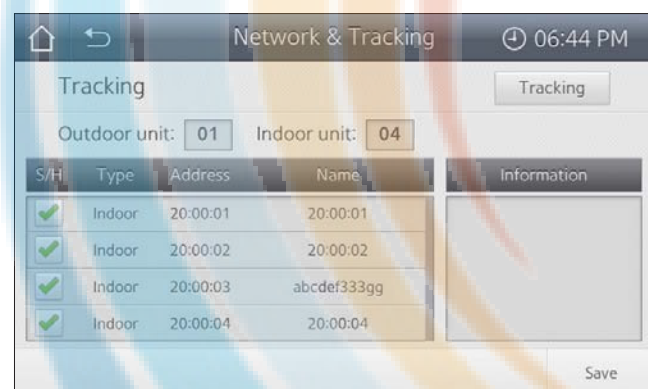

- Indoor unit with no check mark on S/H (Show/Hide) check box, will not be controlled and monitored from the Touch centralized controller.

Wi-Fi kit

MIM-H03UN

Features

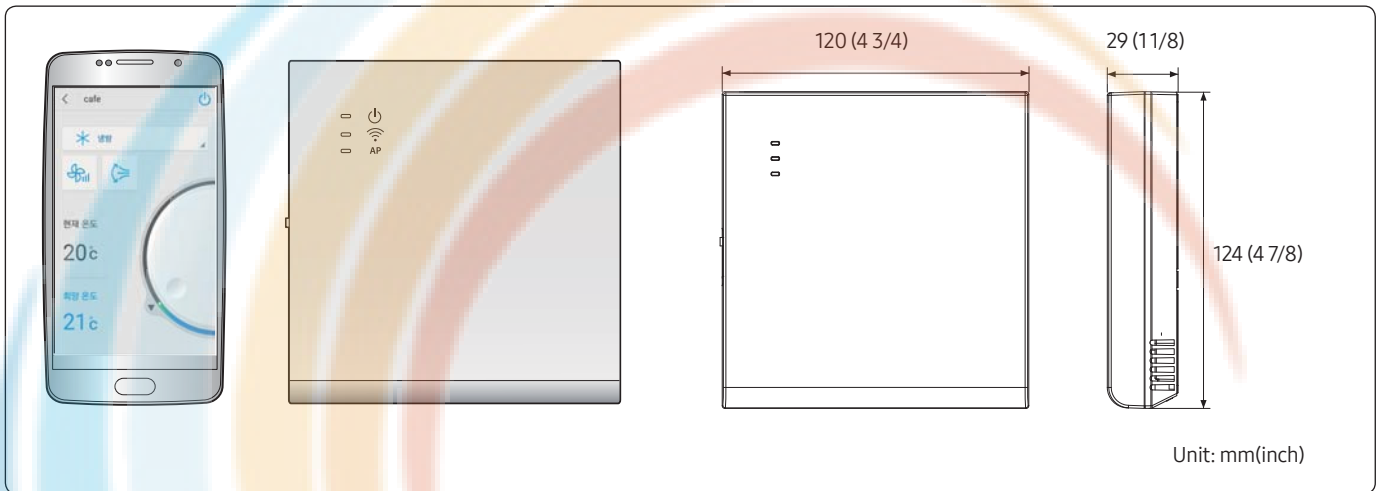

- Control and monitoring system air conditioner by mobile phone. (Max. 16 units)
- Weekly schedule setting
- Group control and monitoring (ON/OFF)
- Current/daily/weekly/monthly energy usage data of outdoor unit. (This function is available in certain outdoor unit model)

Wi-Fi kit > MIM-H03UN

Product specification

Power supply		DC12V			
Power consumption		6W			
Operating temperature range		0°C~40°C (32°F~104°F)			
Operating humidity range		30%RH~90%RH			
Communication	Wired	RS485 (Communication with outdoor unit)			
	Wireless	Wi-Fi 802.11b, g, n, 2.4 GHz (Communication with AP)			
Maximum connection length	RS485	1000m (3280ft)			
	Wi-Fi	20m(66ft) (It depends on AP specification)			
Max. connectable number of device	Set layer	Device		Number	
		Indoor units (including ERV, MCU kit)		16 units. (In case of more than 16 units connection, it displays only 16 units in ascending order of main address.)	
		Outdoor units		1 unit	
		OnOff controller		16 units (Including Wi-Fi kit Max.4)	
		Touch centralized controller			
		Wi-Fi kit			
	Control Layer	Device		Number	
		Indoor units (including ERV)		16 units.	
		Outdoor units (Interface module, ERV interface module)		16 units.	
		OnOff controller		16 units.	
		Touch centralized controller			
		DMS2.5		Total 16 units	
		BACnet gateway			
	Wi-Fi kit				

- Max.5 mobile app users per1 Wi-Fi kit.
- Max.4 Wi-Fi kit registration per1 user account.
- Controller: Controllers which can connect to Set layer (F1/F2) including Wi-Fi kit.

Wi-Fi kit > MIM-H03UN

Compatible product

Outdoor unit	AM*****X*****
ERV	AM*****S*****
Controller	OnOff controller (MCM-A202DUN)
	Touch centralized controller (MCM-A300UN)
	Wi-Fi kit (MIM-H03UN)

- ERV should connect MIM-N10 interface module to connect Wi-Fi kit.

Description of parts

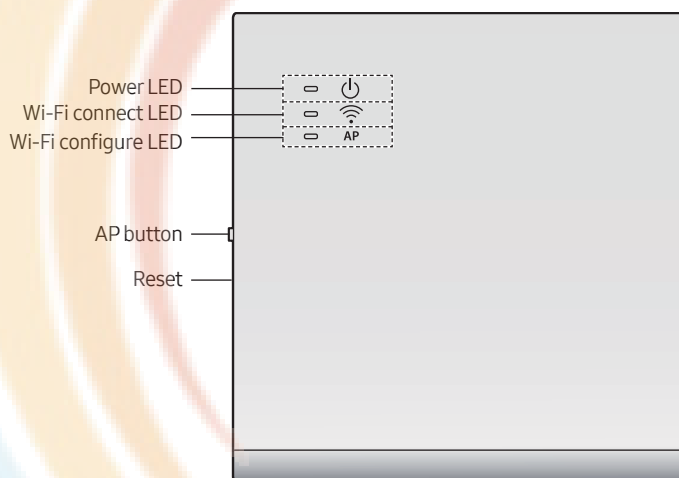

LED display information

No	LED information	Power	Wi-Fi Connect	Wi-Fi Configure
01	Initialized	ON	ON	ON
02	Normal	ON	ON	OFF
03	AP connection OK. but, internet is not connected	ON	Blinking	OFF
04	Air conditioner searching OK. but AP connection is not completed.	ON	OFF	OFF
05	Wi-Fi modem is in malfunction	Blinking	Blinking	Blinking
06	Searching AP (AP mode)	ON	OFF	ON
07	Searching air conditioner	Blinking	Blinking	OFF
08	No air conditioner information	Blinking	OFF	OFF
09	Inspecting network PBA	ON	Blinking	Blinking
10	Requesting a token (AP mode)	ON	OFF	Blinking

02 Centralized control systems
Wi-Fi kit > MIM-H03UN

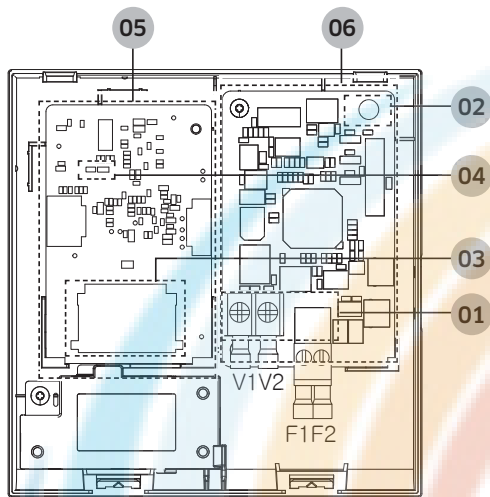

No.	Contents
01	Power/communication connection terminal
02	Tracking/Initializing button *
03	SD card slot
04	LED
05	Network PBA
06	Interface module PBA

* Tracking: Press button for 1 or more second.
 Initializing: Press button for more than 5 seconds

Connection diagram

Wi-Fi kit connection

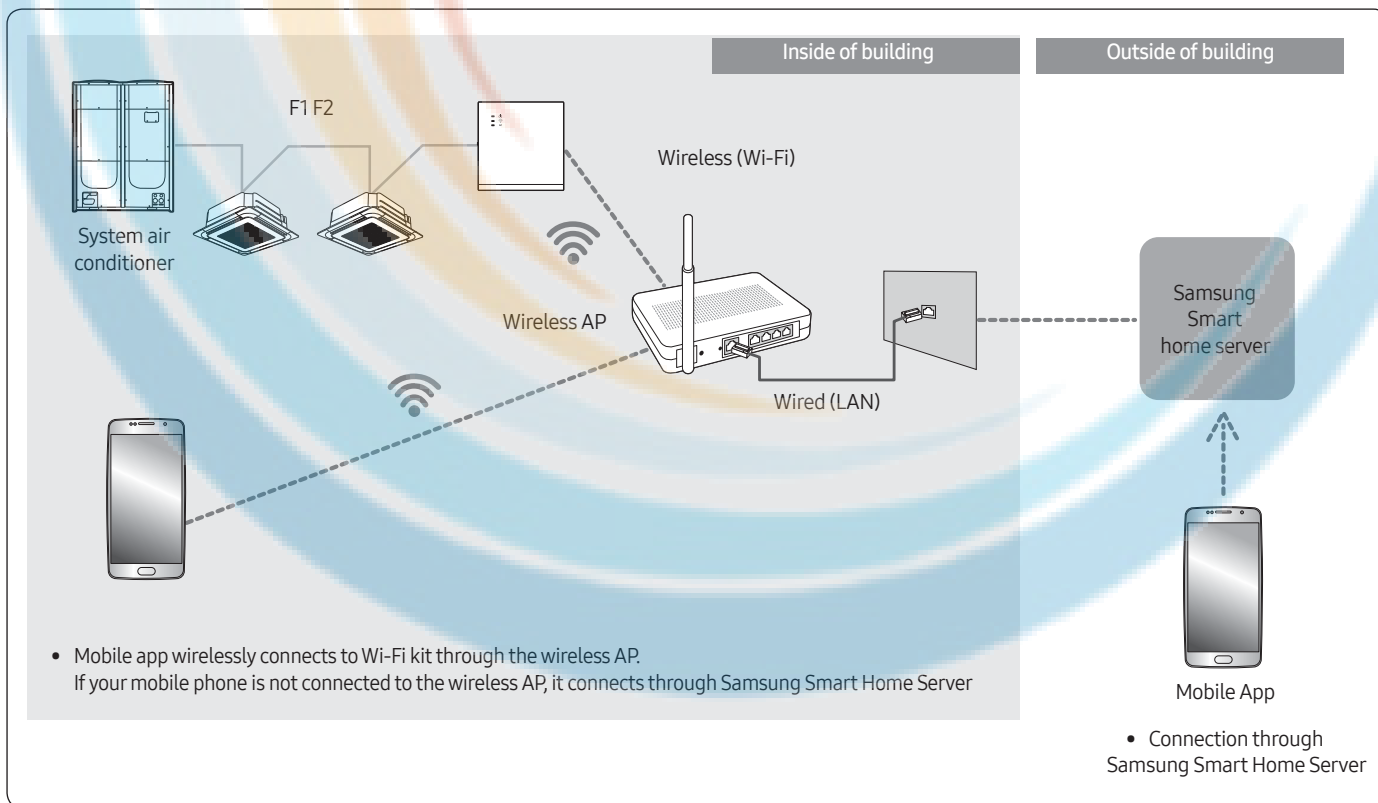

Connection with controllers

Case A (Set layer): Indoor units of outdoor unit 1 will be controlled.

- Wi-Fi kit is connected to Set layer only.
- If Wi-Fi kit uses "Multi tenant" function, then OnOff controller can not be use together.

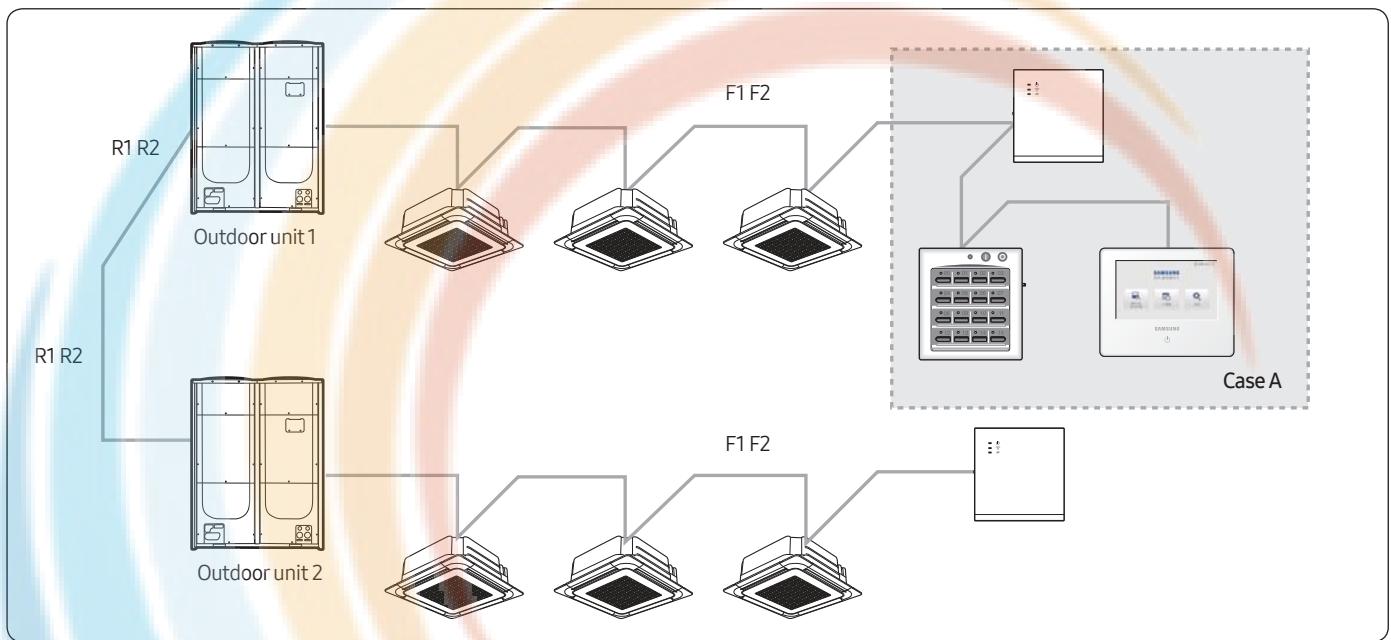

Note

- If controllers set "Remote controller restriction", then Wi-Fi kit is also restricted.

Connection

1) When connected to a single outdoor unit (F1-F2)

※ Connection diagram of Wi-Fi kit

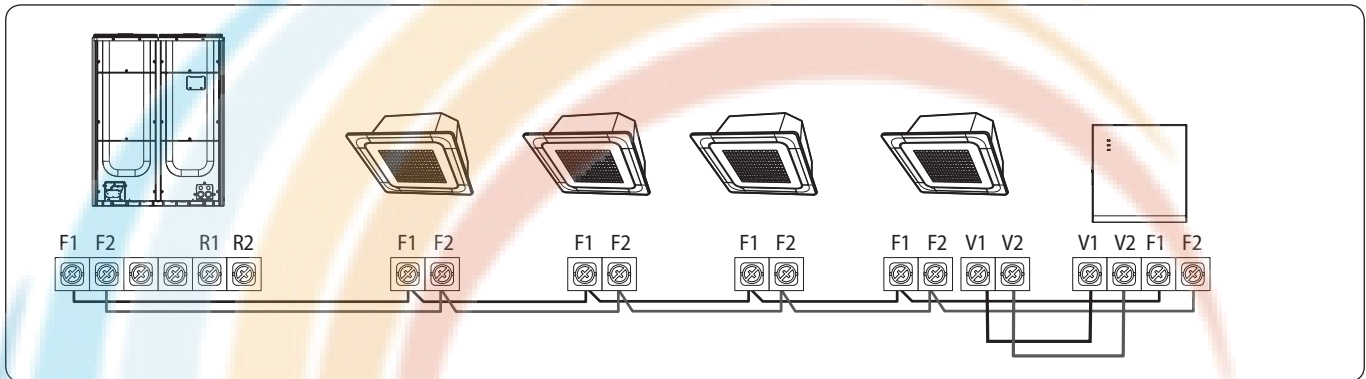

< Connecting the Wi-Fi kit to a multi type product >

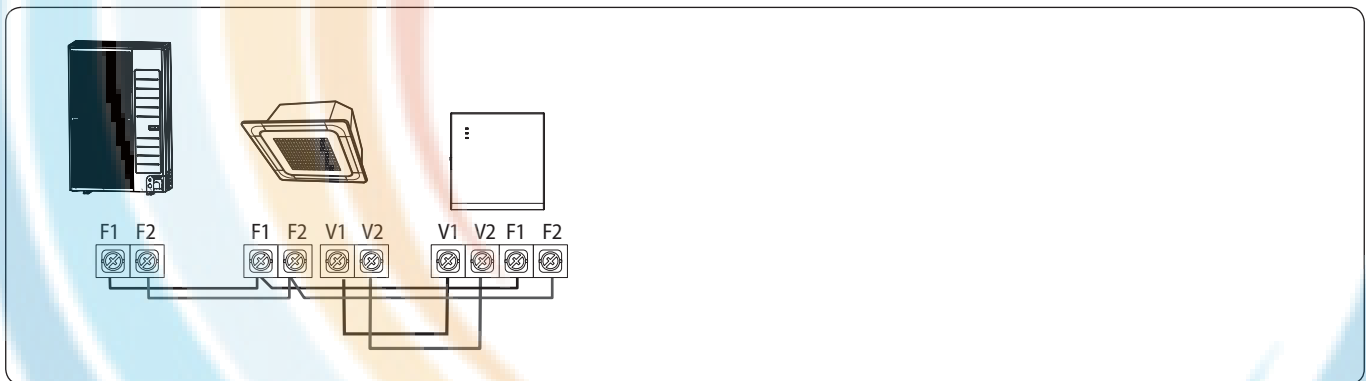

< Connecting the Wi-Fi kit to a single type product >

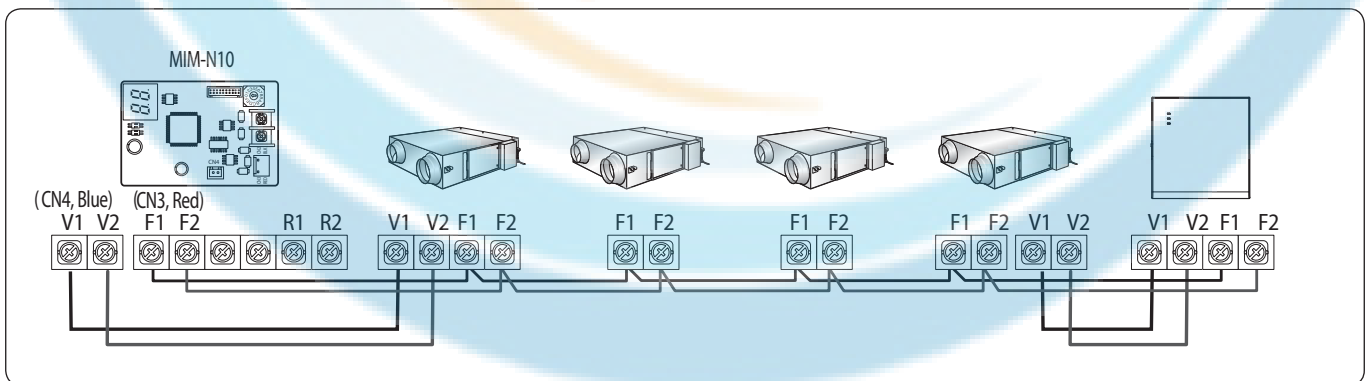

< Connecting the Wi-Fi kit to an ERV Kit product >

02 Centralized control systems
Wi-Fi kit > MIM-H03UN

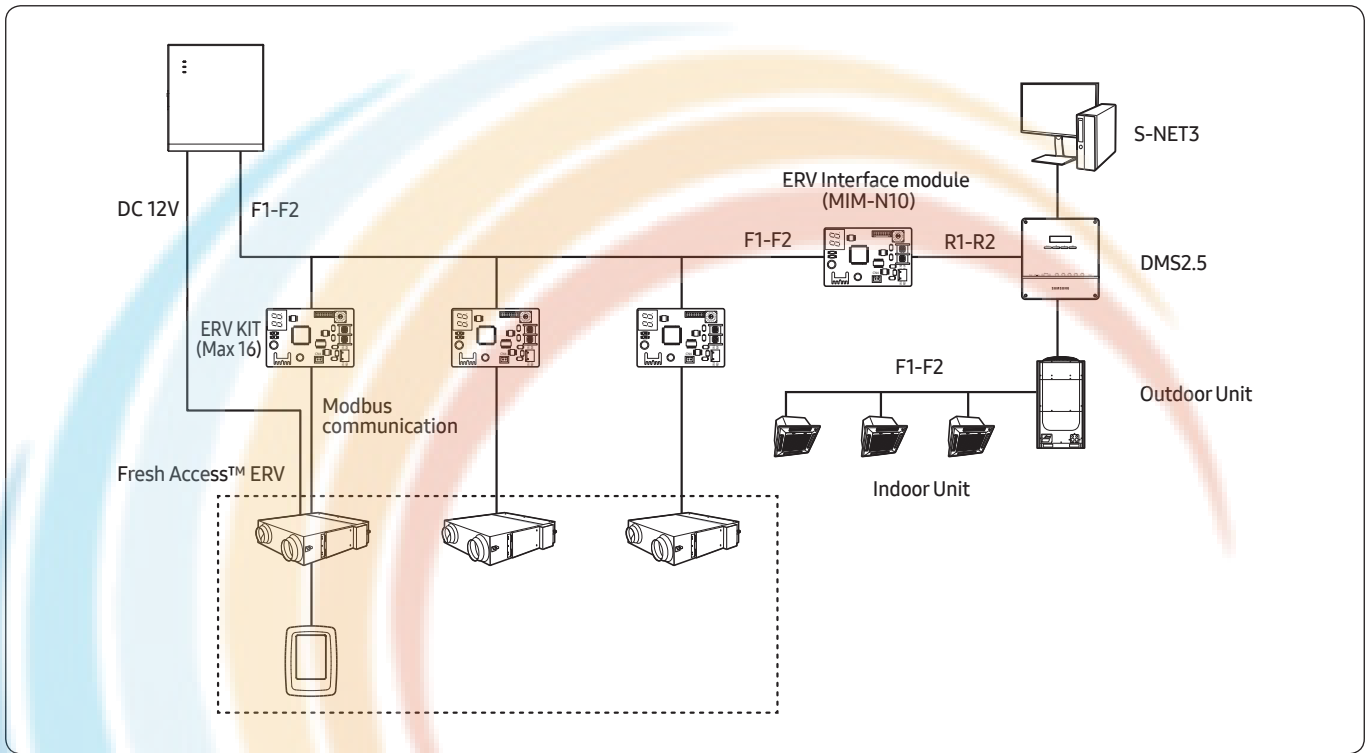

<Connecting the Wi-Fi kit to an ERV Kit product>

⚠ Caution

- New communication applied unit only

2) When connected to two or more outdoor units (R1-R2)

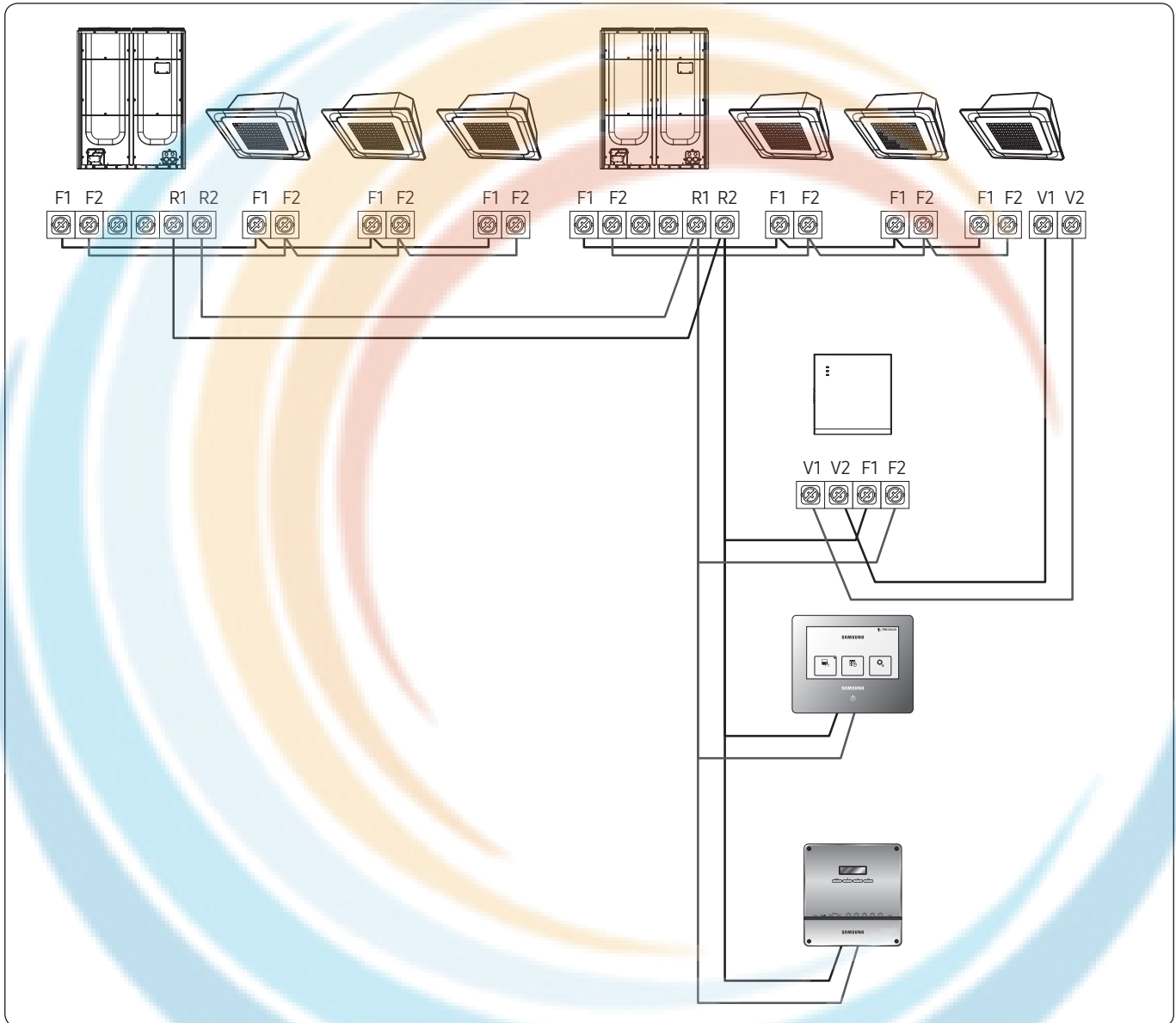

- Connect F1 and F2 of the Wi-Fi kit to R1 and R2 of the outdoor unit.
- Connect the power supply to V1 and V2 of the indoor unit.
- Can install together with other controllers such as touch centralized controller and DMS 2.5.

3) When installing with ERV (R1-R2)

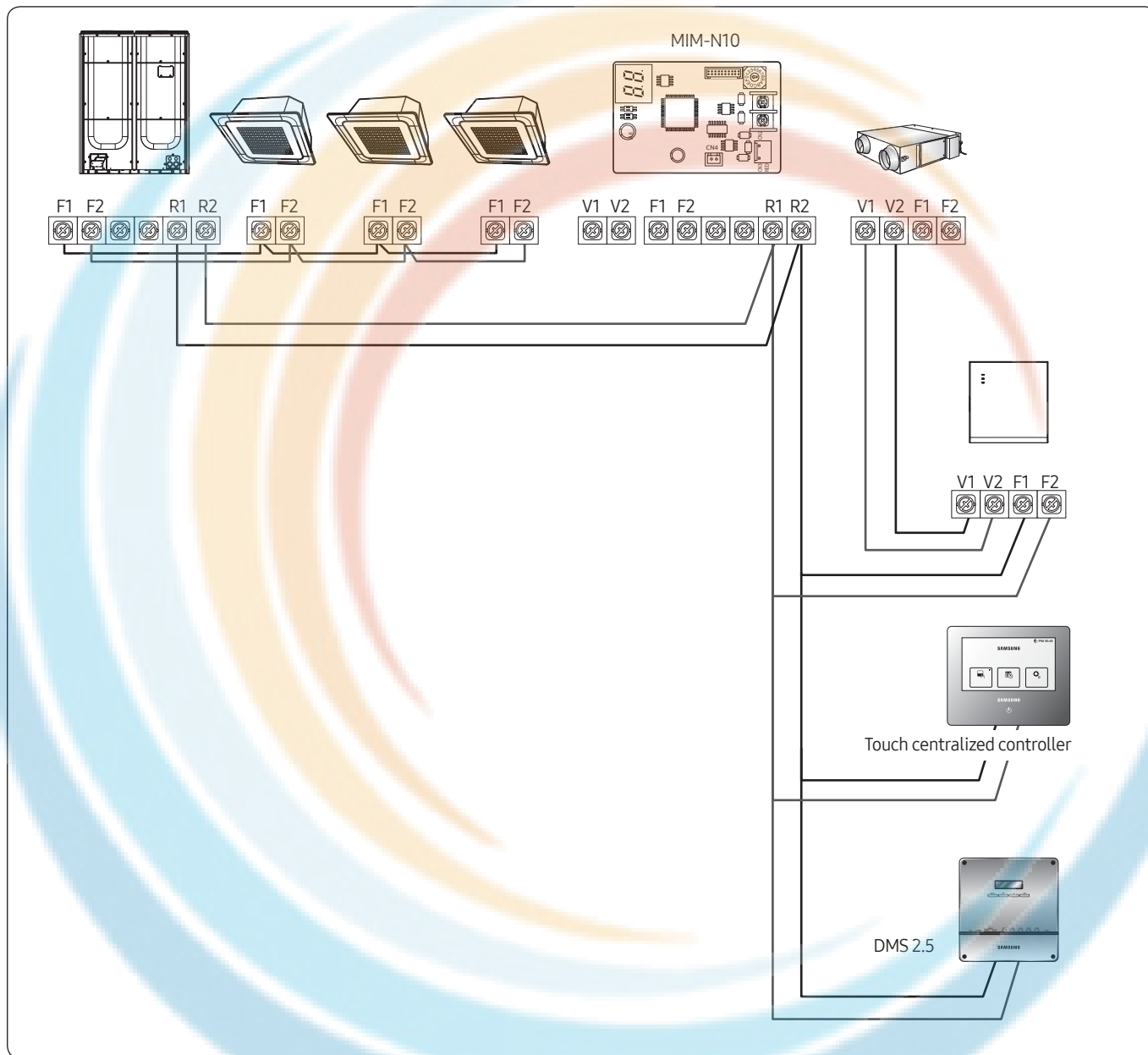

- Connect F1 and F2 of the Wi-Fi kit to R1 and R2 of the outdoor unit.
- Connect the power supply to V1 and V2 of the indoor unit, ERV or ERV Kit.
- Can install together with other controllers such as Touch centralized controller and DMS 2.5.

⚠ Caution

- Up to 16 indoor and outdoor units can be connected.
- When it is connected to two or more outdoor units, some functions including energy monitor can be restricted.

Main function

Control and monitoring by mobile phone

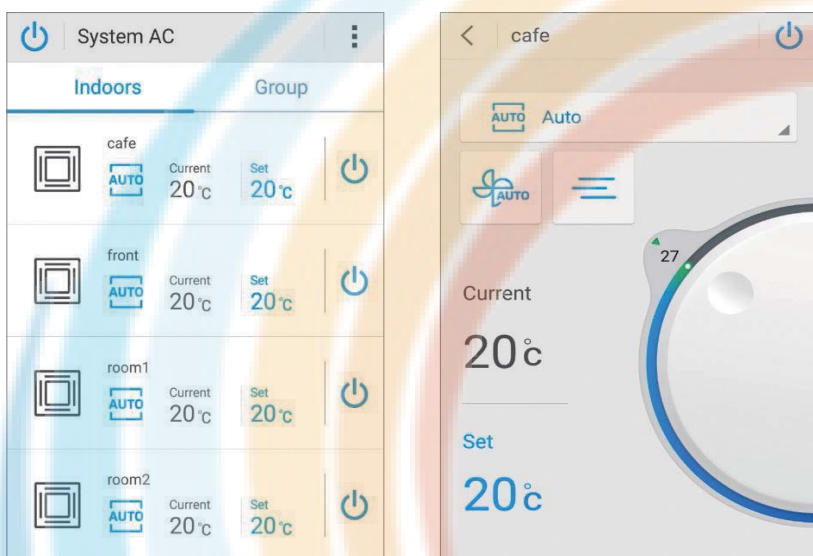

- You can control all connected indoor units of Wi-Fi kit (Max.16 units)
- You can turn ON/OFF all indoor units together.
- You can control individual indoor unit in detail.
 (Detailed settings: Operation ON/OFF, operation mode, temperature setting, fan speed, air flow direction, Wind-Free)
- You can rename indoor units.

Note

- In case of more than 16 units are connected, Wi-Fi kit displays only 16 units in ascending order of main address.

Group control

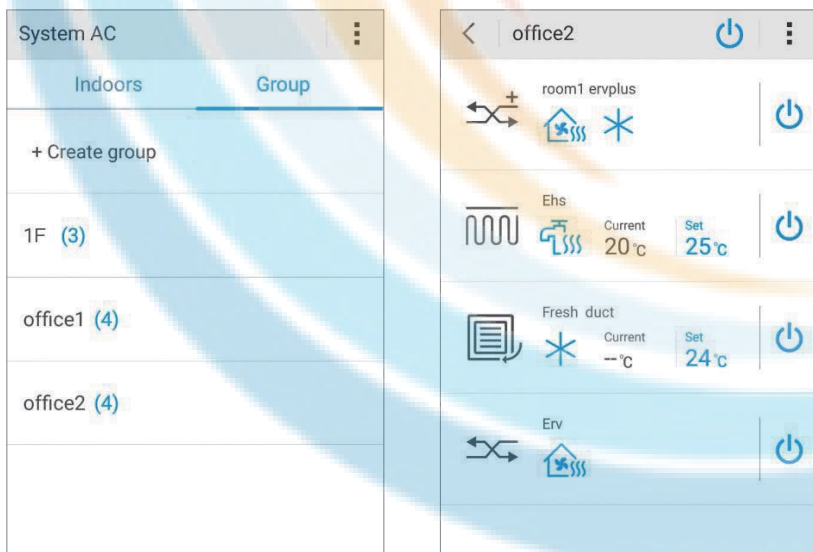

- You can create group. (Max.16 groups)
- You can turn ON/OFF all indoor units of group at once.
- If you select individual indoor unit of group, then you can control it in detail. (Detail setting: Operation ON/OFF, operation mode, temperature setting, fan speed, air flow direction, Wind-Free)

Schedule control

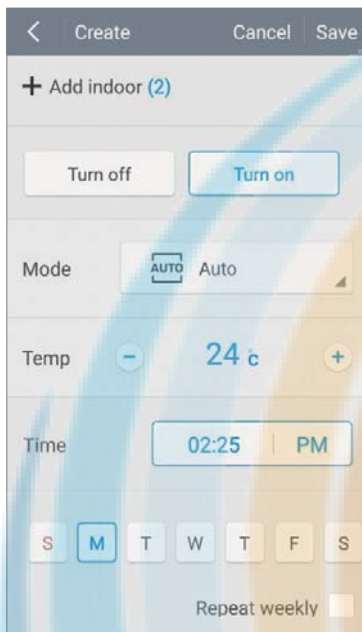

- You can set weekly schedule. (Max.10 schedules. Possible to repeat it within the period)
- You can apply the schedule setting to multiple indoor units.
- You can set detailed operation if you set “On” schedule. (Operation mode, temperature setting)

Energy monitor

- You can check the current/daily/weekly/monthly energy usage data of outdoor unit. (This function is available in certain outdoor unit model)

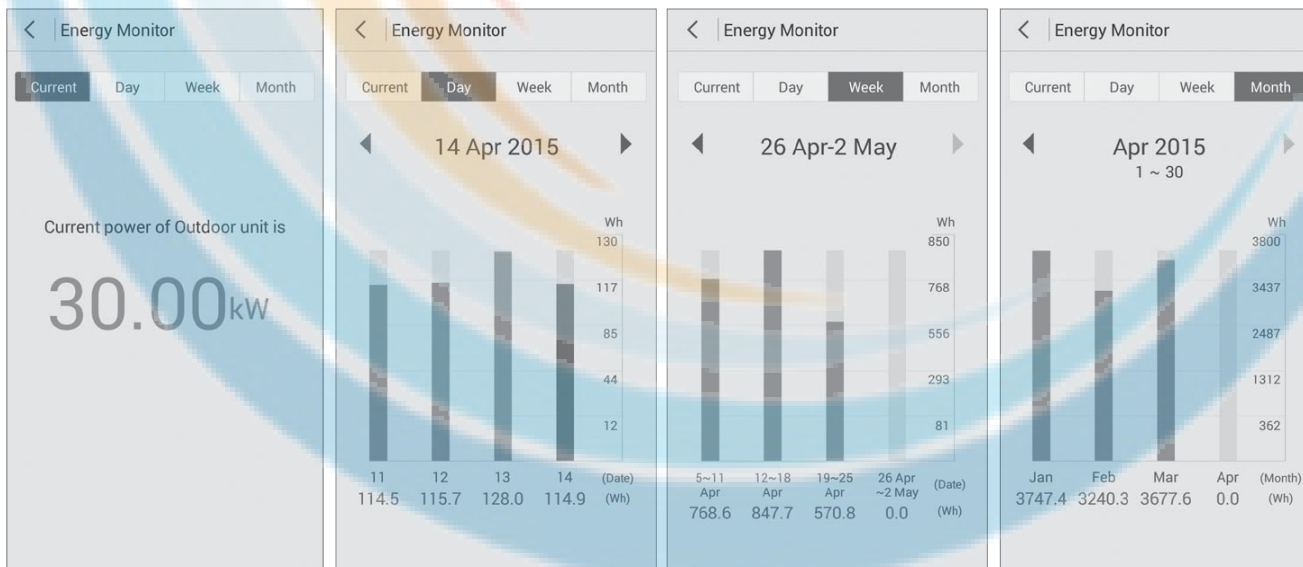

Note

- Energy Monitor displays power consumption which is different from power consumption shown on electricity bills.
 - This function is only available for the products that provides energy usage data.
 - When a Wi-Fi kit is connected to two or more outdoor units, the Energy Monitor does not appear.

Setting individual usage of indoor unit

For individual usage of indoor units connected to outdoor unit, installing multiple number of Wi-Fi kit allows classifying indoor units by group channel address (RMC1).

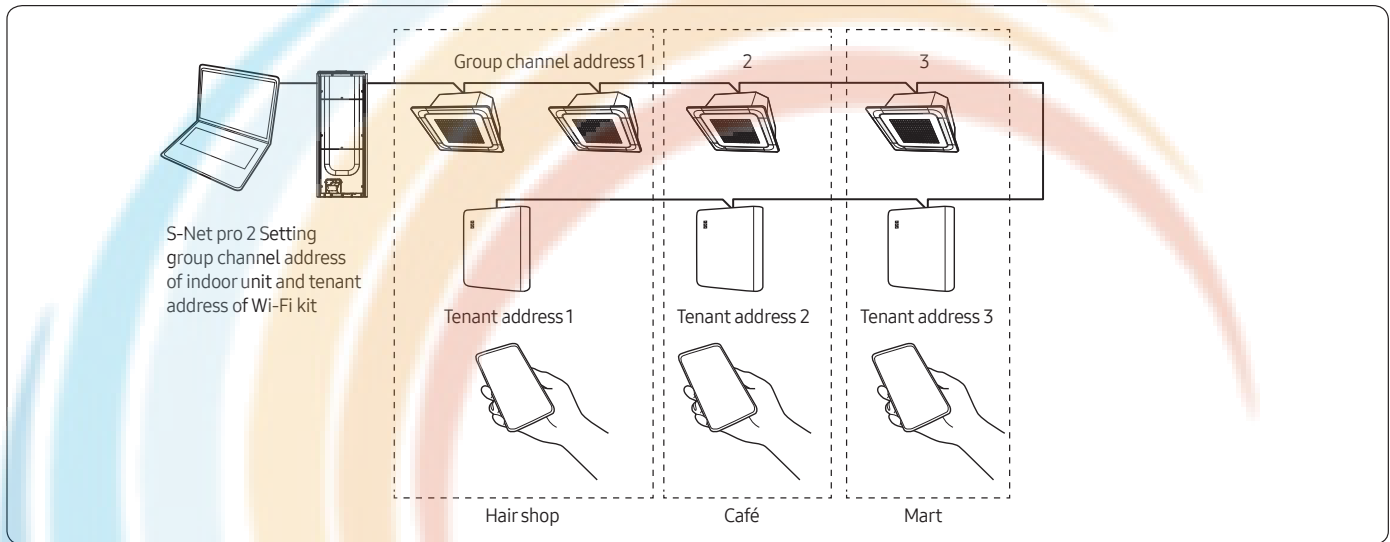

Note

- Multi tenant function is to set controlling and monitoring of indoor units assigned to one group channel address (RMC1) by identical tenant address of Wi-Fi kit.
- Install Wi-Fi kits as number of groups to use.
 - Maximum number of Wi-Fi kit that can be connected to outdoor unit module is 4.
 - Maximum number of indoor unit that can be connected to Wi-Fi kit is 16.

Note

- You can change names of each Wi-Fi kit on your smartphone. You cannot change names of other connected smartphones.
- Set tenant address to each Wi-Fi kit by Wi-Fi kit setting function on installing program (S-Net pro 2).

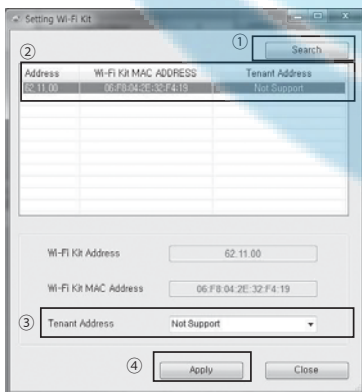

- 1 Click Search to find connected Wi-Fi kits.
- 2 Select one MAC address among searched Wi-Fi kits.
 - MAC address can be found on the label inside of Wi-Fi kit.

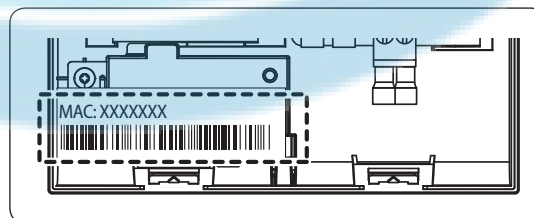

3 Set tenant address. (Not support, 0 ~ F)

- Enter tenant address to S-NET pro 2, and it will be applied as below.

Tenant address	Group channel address of indoor unit controlled by W-Fi kit
Not Support	Control all indoor units connected to outdoor unit
0	Control indoor units assigned to group channel address 0
1	Control indoor units assigned to group channel address 1
2	Control indoor units assigned to group channel address 2
3	Control indoor units assigned to group channel address 3
4	Control indoor units assigned to group channel address 4
5	Control indoor units assigned to group channel address 5
6	Control indoor units assigned to group channel address 6
7	Control indoor units assigned to group channel address 7
8	Control indoor units assigned to group channel address 8
9	Control indoor units assigned to group channel address 9
A	Control indoor units assigned to group channel address A
B	Control indoor units assigned to group channel address B
C	Control indoor units assigned to group channel address C
D	Control indoor units assigned to group channel address D
E	Control indoor units assigned to group channel address E
F	Control indoor units assigned to group channel address F

- Ex.) If tenant address 2 is entered to Wi-Fi kit by S-NET pro 2, only indoor units assigned to 2 for RMC1 will be the target of controlling and monitoring.

4 Click Apply and the tenant address will be saved on Wi-Fi kit.**Note**

- Refer to "Setting an indoor unit address and installation option" in installation guide of indoor unit to set indoor unit group address. (SEG9: 1, SEG 11: RMC1)
- If you want to reset the tenant address, please contact Samsung service center.
- To control all indoor units classified by tenant address with one smart phone, each Wi-Fi kit should be registered on the smartphone.
- When using multi tenant function by Wi-Fi kit, upper controllers other than OnOff controller (such as Touch centralized controller, DMS, etc.) can be installed at the same time.

Wi-Fi kit > MIM-H03UN

Note

- Data storage

Data	Location	
	Wi-Fi kit	Mobile phone
Group information	-	0
Indoor unit name	0	-
Schedule setting	0	-
Settings	△ (Set temp. unit/Set temp. scale)	△ (Heat temp. range)
Device installation information (Number of indoor unit, Address, etc)	0	-
Energy usage of outdoor unit (6 months)	0	-
Connection information	0	0

- Initialization
 - Initializing button: Reset to factory default state.
 - Mobile app deletion: Deletes every data relating Wi-Fi kit in mobile phone.

Caution

- After initialization, you must register Wi-Fi kit to Mobile app again.

MCM-A00UN

Features

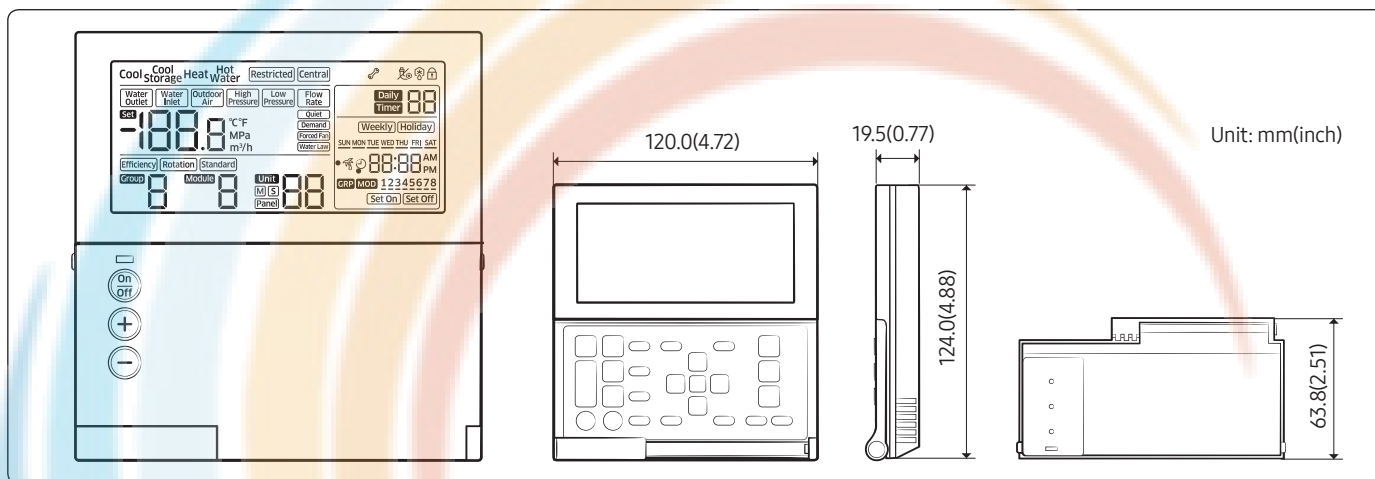

- DVM CHILLER On/Off control (Module/Group)
- Operation mode, water outlet temperature setting
- Optional operation setting
- Module/Group setting
- Weekly operation schedule setting

Product specification

Power Supply	DC 12V
Power Consumption	2W
Operating Temperature range	0°C~40°C (32°F~104°F)
Operating Humidity range	30%RH ~ 90%RH
Communication	2-wire PLC
Max. Communication length	200m (656ft)
Max. Number of connection	16 DVM CHILLER units





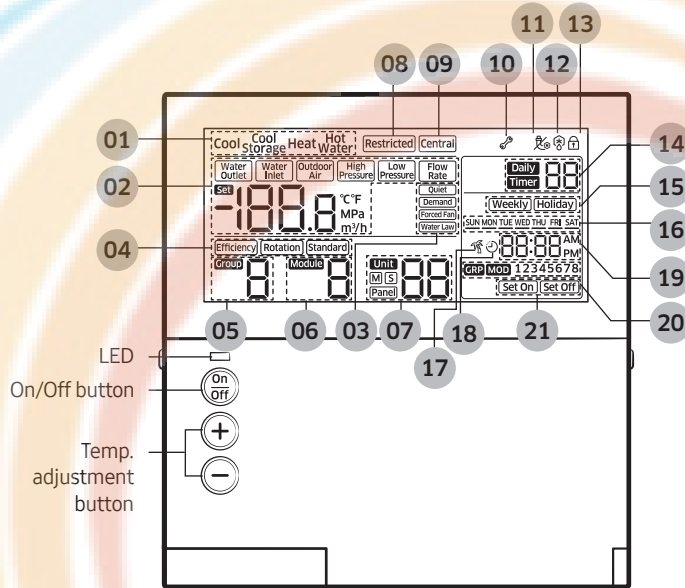





Description of parts

Display





No.	Display	Function
01	Cool Cool Storage Heat Hot Water	Displays the operation mode.
02		Displays the set or current water temperature (°C, °F). NOTE <ul style="list-style-type: none"> Press button to display the set water temperature for 3 seconds. The default is the current water temperature, and it can be changed into the set water temperature in the service setting mode. The display will show Lo when the value can be displayed (-199 ~ 199) or show HI when it cannot be displayed. Displays the current temperature (°C, °F) of water inlet or outdoor air. Displays the current high or low pressure (MPa) of refrigerant. Displays the current water flow rate (m ³ /h).
03		Displays the selected applied operation.
04		Displays the operation pattern by each module and group.
05		Displays the group from 1 to 4.
06		Displays the module from 1 to 8.





Module Controller > MCM-A00UN

No.	Display	Function
07		<p>Displays the unit from 0 to 15 (maximum 16).</p> <p>Displays Master or Slave.</p> <p>Displayed when setting the Panel control function from a certain unit.</p> <ul style="list-style-type: none"> Panel control function is to set the unit to control the operation itself, so the operation cannot be controlled from the module control if this function is set.
08		<p>Displayed when button input is restricted.</p> <p>Restricted display will appear when the buttons are restricted due to central control or when a combined operation cannot be performed.</p> <p>NOTE</p> <ul style="list-style-type: none"> The module control will be restricted in the following cases. Example1) Displayed when pressing  button in the central control. Example2) Displayed when setting the button lock function and then  button in the service mode.
09		<p>Displayed when setting the central control.</p> <p>NOTE</p> <ul style="list-style-type: none"> Central display will appear when the module control is controlled by the central control room of the building or by the upper level control such as a central control or a DMS etc. In this case, timer and all functions will be operated by the upper level control.
10		<p>Displayed when an error occurs in a product or a module control.</p> <p>NOTE</p> <ul style="list-style-type: none"> Blinked when an error occurs in a product or a module control, followed by the error code. It will disappear when all errors is solved.
11		<p>Displayed when a pump operates automatically to keep the pipes from freezing.</p>
12		<p>Displayed when the defrost function operates.</p> <p>NOTE</p> <ul style="list-style-type: none"> Defrost function is to remove frost on the outdoor unit during operating the heat mode.
13		<p>Displayed when selecting the button lock function.</p> <p>NOTE</p> <ul style="list-style-type: none"> To lock the buttons of the module control, press  button.
14		<p>Displays the number of daily or entire timers.</p>

Module Controller > MCM-A00UN

No.	Display	Function
15	Weekly Holiday	Displays weekly timer or holiday setting.
16	SUN MON TUE WED THU FRI SAT	Displayed days of week while setting weekly or daily timer or displaying the set timer.
17		Displayed when the summer time function is set.
18		<p>Displayed when setting the off timer for the entire DVM CHILLER in the additional function. Time for the off timer function can be set to maximum 23 hours.</p> <p>NOTE</p> <ul style="list-style-type: none"> The current time will be displayed if there is more than an hour until the set time. The remaining time will be displayed and the off timer display will appear if there is less than an hour until the set time.
19	88:88 AM PM	Displays the current time or the set time.
20	GRP MOD 12345678	Displayed when selecting a group or a module while setting the weekly timer. (Group: 1 ~ 4, Module: 1 ~ 8)
21	Set On Set Off	Displayed Set on or Set off while setting or displaying timer.







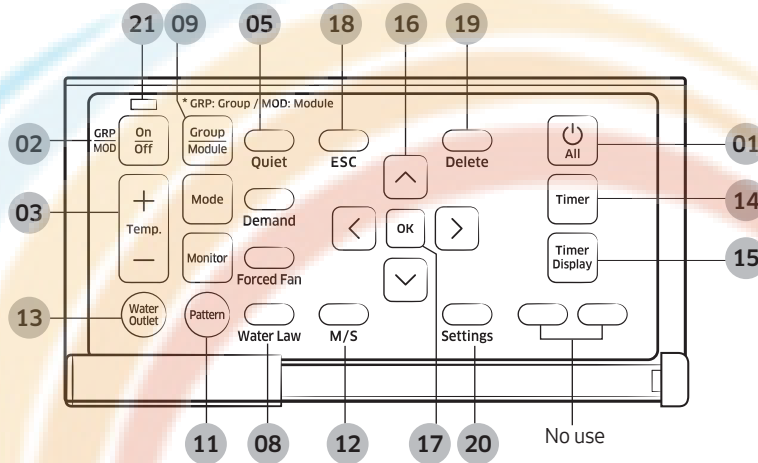

NOTE

- If you set the input method as external contract control in the option setting of DVM CHILLER, the module control cannot control the units.
 - When pressing  , or , or  button on the module control, the displays will appear on the display but the DVM CHILLER will not operate.
- The module control cannot sense the indoor temperature.
- The module control does not control the midnight electricity's time or the cool storage tank.













Module Controller > MCM-A00UN

Buttons

















Classification	Indication	Function
Start/Stop	01  All start/stop button	Turns on or off all the DVM CHILLERS. You can turn on or off all the connected modules and groups. NOTE <ul style="list-style-type: none"> When turning off all units and turn them back on, the units will operate in a previously selected mode.
	02  On/Off button	Turns on or off a group or a module individually. When a module or a group is turned off, temperature or mode displays will not appear. NOTE <ul style="list-style-type: none"> When turning off a module or a group and turn it back on, each module or group will operate in a previously selected mode.
Basic operation	03  Temp. adjustment button	Adjusts the desired water temperature. NOTE <ul style="list-style-type: none"> For celsius, the set water temperature can be adjusted by 1, 0.5, or 0.1 °C depending on the set value in the service mode. For fahrenheit, it can be depending on the set value in the service mode. For fahrenheit, it can be adjusted by 1 °F. If you press and hold the button, it will be adjusted by 1 °C/1 °F.
	04  Operation mode button	Selects the desired operation mode.
Applied operation	05  Quiet button	Selects the quiet function.
	06  Demand button	Selects the demand function.
	07  Snow prevention button	Selects the snow prevention function.
	08  Water law button	Selects the water law function.

Module Controller > MCM-A00UN

Classification	Indication	Function
Option change function	09  Group/Module button	Selects a group or module control.
	10  Monitor button	Shows the result of monitoring water outlet, water inlet, outdoor air, high and low pressure of refrigerant, and water flow rate.
	11  Pattern button	Sets the operation pattern when controlling the DVM CHILLER by groups or modules.
	12  M/S button	Sets Master or Slave units.
	13  Water outlet button	When pressing the water outlet button while the display shows the pressure of refrigerant or the water inlet temperature, the water outlet temperature will be displayed.
Timer function	14  Timer button	Sets the weekly On/Off timer. NOTE • The timer can be set up to maximum 40 timers.
	15  Timer display button	Checks the timer already set. NOTE • You can check the timer by numbers or days of the week.
Common function	16  Up, down, left, right button	Moves from stage to stage or changes the set value.
	17  OK button	Selects the stage or saves the setting.
	18  ESC button	Exits to normal mode without saving your changes while setting the timer or the additional function.
	19  Delete button	Deletes the timer. NOTE • Press button for 3 seconds to delete all the timers while the display shows the timers.
	20  Settings button	Enters the additional function setting screen.
LED	21  LAMP	Displays the on/off status of the module or the group on the display. - On: green LED is turned on - Off: green LED is turned off - Error: red LED is blinking NOTE • When one of the modules or groups are operating, the green LED is turned on. • When a certain module or group needs to be inspected, the led LED is blinked.

NOTE

- Mode, temperature, or etc. can be set when only the module control is turned on.
-            +   +  buttons can be used when the module control is turned off.

Module Controller > MCM-A00UN

Connection diagram

1:1 connection

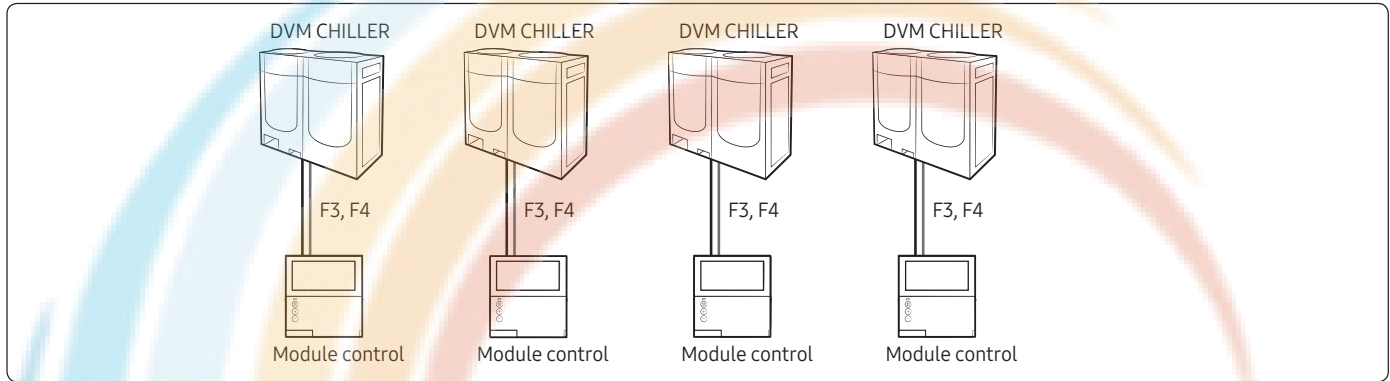

1:N connection

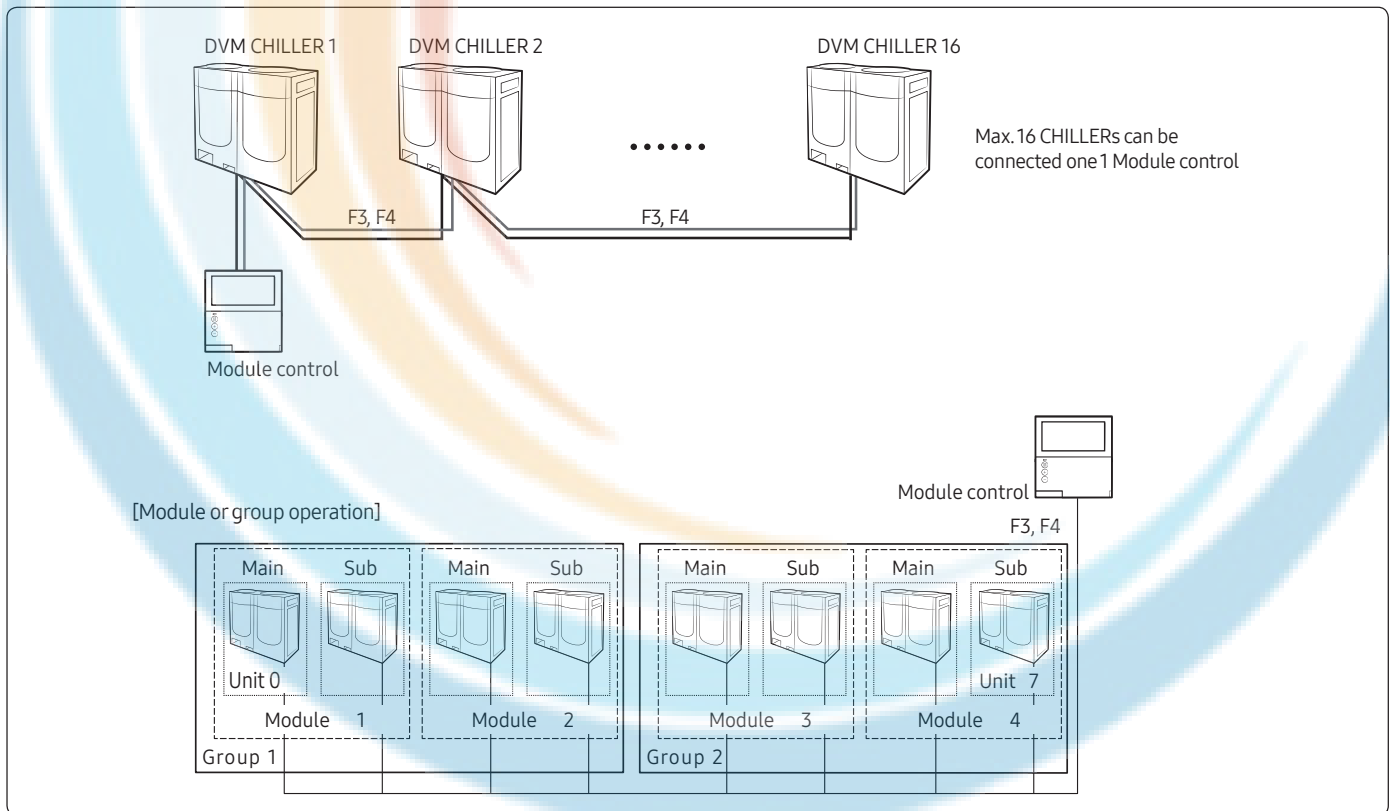

- Module/group operation is to combine multiple CHILLERs in modules or groups of a single water pipe system and to operate them depending on the working condition.
- A single module control can control a maximum of 16 DVM CHILLERs (0 ~ 15). DVM CHILLER can have a maximum of 8 modules (1 ~ 8) and 4 groups (1 ~ 4). A maximum of 8 units can be connected to a module, and a maximum of 8 modules can be connected to a group.

Module Controller > MCM-A00UN

Optional function

Additional setting mode

- How to set “Additional setting mode”
Press “Settings” to enter “Additional setting mode”

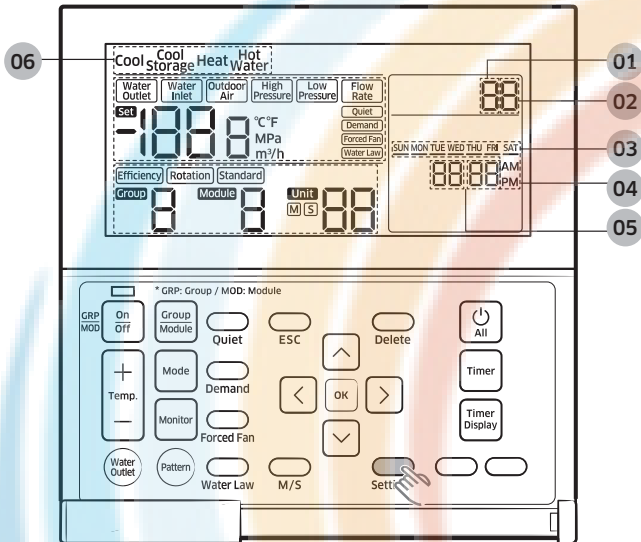

No.	Name	Description
01	Main menu	Displays main menu value of the service mode table.
02	Sub menu	Displays sub menu value of the service mode table.
03	Page	Displays Page value of the service mode table.
04	Data Segment	Displays Data value of the service mode table.
05	Synchronized segment for setting the current time	Displays the data value of the Page on the left side of the LCD at the same time.
06	The status of each unit	Displays the status of each unit when selecting the monitoring function by each unit in the user mode.

Main menu	Sub menu	Function	Initial value	Page	Range	Save	
1	1	Off timer	0	1	00 ~ 12 hour(s) (by an hour)	Save	
3	1	Lock all	0	1	0 - Unlock, 1 - Lock	Save	
	2	Lock timer	0	1	0 - Unlock, 1 - Lock	Save	
4	1	Set today's date	(yy) year	-	1	00 ~ 99	Save
			(mm) month	-	2	01 ~ 12	Save
			(dd) day	-	3	01 ~ 31	Save
			week) day of week	-	4	Sun. ~ Sat. (0 ~ 6)	Save

Module Controller > MCM-A00UN

Main menu	Sub menu	Function		Initial value	Page	Range	Save
4	2	Set the current time	Hour: Minute	-	-	Setting range of hour • 12-hours: (AM/PM) 01 ~ 12 • 24-hours: (AM+PM) 00 ~ 23 • Setting range of minute: 0 ~ 59	Save
5	1	Use and set the summer time function	Use the summer time function or not	0	1	0 - No use, 1 - Use	Save
			Set the summer time type	0	2	0 - by a week, 1 - by a day	Save
	2	Start the summer time function (by a week)	Month	3	1	01 ~ 12 (Jan. ~ Dec.)	Save
			Sunday on the selected week	F	2	1 ~ 4 (week) or F - the last week	Save
	3	Start the summer time function (by a week)	Month	10	1	01 ~ 12 (Jan. ~ Dec.)	Save
			Sunday on the selected week	F	2	1 ~ 4 (week) or F - the last week	Save
	4	Start the summer time function (by a day)	(mm) month	3	1	01 ~ 12 (Jan. ~ Dec.)	Save
			(dd) day	22	2	01 ~ 31 (day)	Save
	5	End the summer time function (by a day)	(mm) month	9	1	01 ~ 12 (Jan. ~ Dec.)	Save
			(dd) day	22	2	01 ~ 31 (day)	Save
6	1	Set/check the time for backlight		5	1	00 ~ 30 (second) (Disuse when it is 00)	Save
	2	Use LED (green) or not		1	1	0 - No use, 1 - Use	Save
	3	Use LED (red) or not		1	1	0 - No use, 1 - Use	Save
9	1	User setting functions	Display the operating status by units ^{1*)}	The smallest unit number	1	00 ~ 15	-
	2		Display the number of temperature control devices/thermostats	The number of the temperature control devices/thermostats	1	00 ~ 16	-
0	1	Reset to the default value of user mode (except the current time)		0	1	0 - No use, 1 - Reset	-

^{1*)} You can check the status of units connected to the module control.

When pressing  button after selecting the unit number, you can change the status of the selected unit. (Water Outlet → Water Inlet → Outdoor Air → High Pressure → Low Pressure → Flow Rate →).

Press ,  button to change the unit number.

NOTE

- 'Summer Time' means 'Daylight Saving Time'.

Module Controller > MCM-A00UN

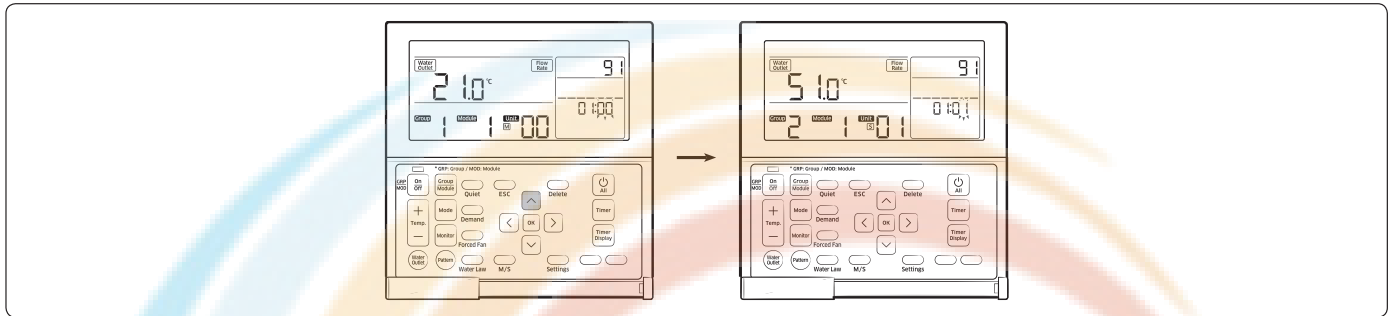

NOTE

- The summer time is to put the clock ahead an hour earlier than standard time in summer.

Service mode

How to set the service mode

- Start the service mode.

+ Press for over 3 seconds

Caution

- To make it work correctly, you have to press the center of the buttons at the same time.

- Select a main menu number.

/ ▶ Select a main menu number

- Select a sub menu number.

▶ / ▶ Select a sub menu number

- Select a Page number.

When changing a Page number, the display will show the set data value of the Page.

▶ / ▶ Select a Page number

- Set Data value.

Refer to the table in “Service setting mode” for setting each data.

▶ / ▶ Adjust the data value

- Save the data setting value.

- Complete the service mode.

NOTE

- If the current setting stage is in the main menu when pressing button, the service mode will be completed. If not, the stage will move to the main menu.
- ‘Summer Time’ means ‘Daylight Saving Time’.

Module Controller > MCM-A00UN

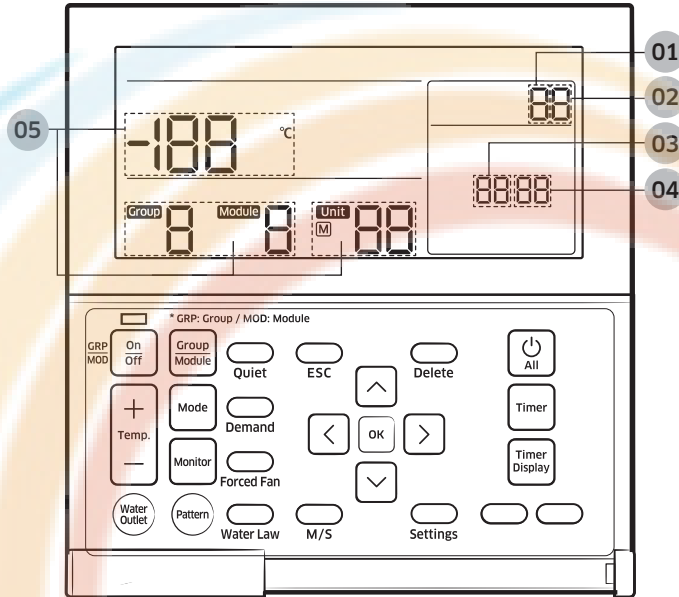

No.	Name	Description
01	Main menu	Displays main menu value of the service mode table.
02	Sub menu	Displays sub menu value of the service mode table.
03	Page	Displays Page value of the service mode table.
04	Data Segment	Displays Data value of the service mode table.
05	Synchronized segment for setting the current time	Displays the data value of the Page on the left side of the LCD at the same time.

Module Controller > MCM-A00UN

Service setting mode

- After saving the setting, the DVM CHILLERS and the module control may be initialized if it is necessary.
- When entering the service mode during the tracking, you can enter the Data stage on the Main menu 4,5,6,9 (Save at DVM CHILLER) but you cannot change the setting.
 - The display will show Restricted if you press button.
 - The display shows only the collected data during the tracking.

Main menu	Sub menu	Function		Initial value	Page	Range	Save
1	1	Option setting/ checking	DVM CHILLER cooling and heating/only cooling	0	1	0 - Cooling and heating, 1 - Only cooling	Save at Module control
			Temperature unit display (°C)/(°F)	0	2	0 - Celsius (°C), 1 - Fahrenheit (°F)	Save at Module control
	2	Option setting/ checking 2	Temperature display set temperature/water temperature (Setting the module control's temperature display value)	1	1	0 - Set temperature 1 - current water outlet temperature (Default value)	Save at Module control
	6	Number of connected units	Number of DVM CHILLERS	0	1	00 ~ 16	-
	7	Setting the unit of the desired temperature (Available only when the temperature display is °C.)		0	1	0 - 1 1 - 0.5 2 - 0.1	Save at Module control
	8	Setting type of time		0	1	0 - 12-hours, 1 - 24-hours	Save at Module control
	9	Check for timer IC error		0	1	0 - Normal, 1 - Error	-
	0	Initializing service mode setting value		0	1	0 - Disuse, 1 - Reset	-
2	1	Checking micom codes of the module control		-	1 ~ 3	Micom code	-
	2	Checking the version information of the module control program		-	1 ~ 3	Modified date	-
4	1	Setting DVM CHILLE number/ option ^{1)*}	Setting a targeted DVM CHILLER	View Master	1	A registered unit number	-
	4		Setting/checking basic options	Basic options of the target	1 ~ 20	Option code	Save at DVM CHILLER
	5		Setting/Checking installation options	Installation options of the target	1 ~ 20	Option code	Save at DVM CHILLER
	6		Setting/Checking installation options 2	Installation options 2 of the target	1 ~ 20	Option code	Save at DVM CHILLER

Module Controller > MCM-A00UN

Main menu	Sub menu	Function	Initial value	Page	Range	Save
5	Setting DVM CHILLER detailed setting	Demand level ^{2)*}	-	Module number	0 - Default value (100 %) 1 - 95 % 2 - 90 % 3 - 85 % 4 - 80 % 5 - 75 % 6 - 70 % 7 - 65 % 8 - 60 % 9 - 55 % 10 - 50 % 11 - Not applied (unrestricted)	Save at DVM CHILLER
		Quiet operation level ^{3)*}	-	Module number	0 - Default value (100 %) 1 - Level1 2 - Level2 3 - Level3	Save at DVM CHILLER
		Standard for Water law ^{4)*}	-	Main unit number ^{5)*}	Standard for Water Law temperature 0: Based on outdoor temperature/ 1: Based on room temperature	Save at DVM CHILLER
		AirCool1 (for Water law)	-	Main unit number ^{5)*}	Outdoor temperature standard 1 [0 ~ 20°C(32 ~ 68°F)] in cooling mode	Save at DVM CHILLER
		AirCool2 (for Water law)	-	Main unit number ^{5)*}	Outdoor temperature standard 2 [30 ~ 40 °C(86 ~ 104°F)] in cooling mode	Save at DVM CHILLER
		RoomCool1 (for Water law)	-	Main unit number ^{5)*}	Room temperature standard 1 [15 ~ 24 °C(59 ~ 75°F)] in cooling mode	Save at DVM CHILLER
		RoomCool2 (for Water law)	-	Main unit number ^{5)*}	Room temperature standard 2 [25 ~ 35 °C(77 ~ 95°F)] in cooling mode	Save at DVM CHILLER
		Tcool1 (for Water law)	-	Main unit number ^{5)*}	Cooling set temperature standard 1 [-10 ~ 25 °C(14 ~ 77°F)] in cooling mode	Save at DVM CHILLER
		Tcool2 (for Water law)	-	Main unit number ^{5)*}	Cooling set temperature standard 2 [-10 ~ 25 °C(14 ~ 77°F)] in cooling mode	Save at DVM CHILLER

Module Controller > MCM-A00UN

Main menu	Sub menu	Function		Initial value	Page	Range	Save
6	1	DVM CHILLER detailed setting 2	AirHeat1 (for Water law)	-	Main unit number ^{5)*}	Outdoor temperature standard 1 [-20 ~ 5°C(-4 ~ 41°F)] in heating mode	Save at DVM CHILLER
	2		AirHeat2 (for Water law)	-	Main unit number ^{5)*}	Outdoor temperature standard 2 [10 ~ 20°C(50 ~ 68°F)] in heating mode	Save at DVM CHILLER
	3		RoomHeat1 (for Water law)	-	Main unit number ^{5)*}	Room temperature standard 1 [15 ~ 24°C(59 ~ 75°F)] in heating mode	Save at DVM CHILLER
	4		RoomHeat2 (for Water law)	-	Main unit number ^{5)*}	Room temperature standard 2 [25 ~ 35°C(77 ~ 95°F)] in heating mode	Save at DVM CHILLER
	5		Theat1 (for Water law)	-	Main unit number ^{5)*}	Heating set temperature standard 1 [35 ~ 55°C(95 ~ 131°F)] in heating mode	Save at DVM CHILLER
	6		Theat2 (for Water law)	-	Main unit number ^{5)*}	Heating set temperature standard 2 [35 ~ 55°C(95 ~ 131°F)] in heating mode	Save at DVM CHILLER
	9		Operation pattern for modules (When operating standard pattern by a group) ^{6)*}	-	Module number	0 - Standard 1 - Rotation 2 - Efficiency	Save at DVM CHILLER
9	1	Set groups/modules ^{7)*}	Assign modules/groups to units	-	Unit number	Group(1 ~ 4)/ module (1 ~ 8)/ not set '-'	Save at DVM CHILLER
	2	Set a main unit ^{7)*}	Set a main unit for modules	-/-/unit	Module number	Unit number of the selected module	Save at DVM CHILLER
	3		Set a main unit for groups	-	Group number	Unit number of the selected group	Save at DVM CHILLER
	4	Device option	Use Cool storage mode	-	1	0 - Disable, 1 - Enable	Save at DVM CHILLER
	5		Use Hot water mode	-	1	0 - Disable, 1 - Enable	Save at DVM CHILLER
	6	Set a backup module ^{8)*}	Set a backup module	-	Group number	0 - Disable, 1 ~ 8 - The unit number of the selected module	Save at DVM CHILLER

Module Controller > MCM-A00UN

Main menu	Sub menu	Function	Initial value	Page	Range	Save	
0	1	Reset	Initialize factory setting of the module control (Initialize user/service mode setting value)	0	1	0 - No use, 1 - Reset	-
	2		Initialize power master ^{9)*}	0	1	0 - No use, 1 - Reset	-
	3		Initialize DVM CHILLER and module control's addressing	0	1	0 - No use, 1 - Reset	-

^{1)*} In 4-1 menu, the units connected to the module control will be displayed. Select the unit that you want to set and then move to 4-4, 5, 6 menu.

^{2)*} Set a current limit rate. If you set the value less than 100 %, performance may decrease.

^{3)*} Set a level of the Quiet mode. Level3 is the lowest, performance and efficiency may decrease if the Quiet mode operates.

^{4)*} Select a standard for Water law when operating cooling or heating. Water law is to change the water outlet temperature, considering demand load changes according to outdoor or indoor temperature.

According to outdoor temperature

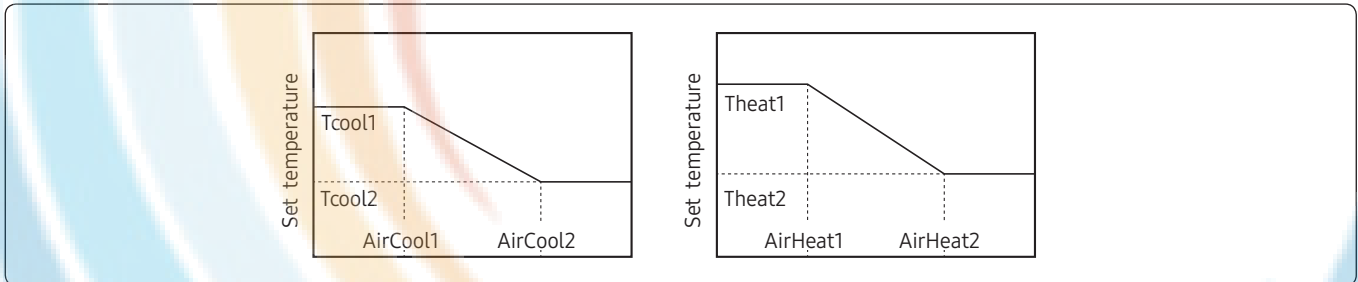

NOTE

- If the unit is not a low temperature water model, the set temperature decided by the Water law control will not decrease below 5°C(41°F).

Module Controller > MCM-A00UN

According to indoor temperature (when using an external temperature sensor)

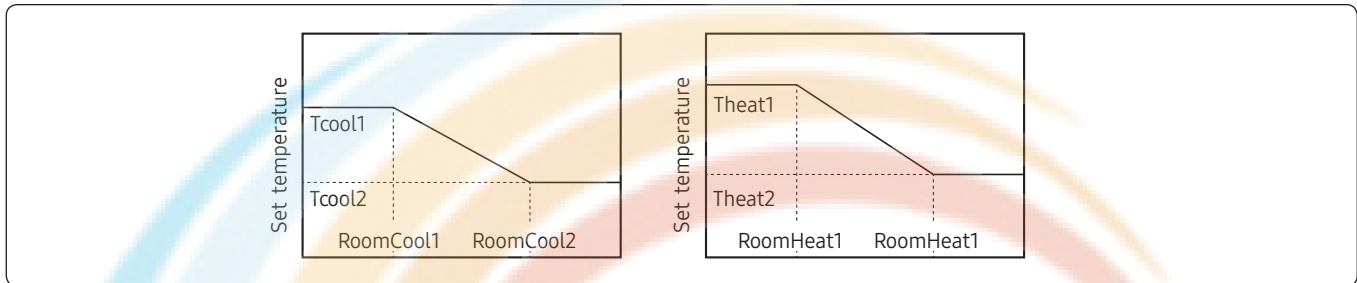

NOTE

- If the unit is not a low temperature water model, the set temperature decided by the Water law control will not decrease below 5°C(41°F).

^{5)*} A main unit of a group or a module will be displayed.

When setting a group, the value for a main unit of the group must be set.

^{6)*} When setting "Standard pattern" for a group, you must set an operation pattern for each module in the group.

^{7)*} Only when completing setting a group or a module and their main units, the module control will operate properly.

When completing the a group or a module setting and then exiting from service mode, the module control will be initialized and the tracking will be performed again.

^{8)*} If a backup unit is selected, the unit will operate depending on the standards for DVM CHILLER.

A backup module does not operate in the normal operation condition. If performance by operating the normal modules is not enough, the backup module will operate.

^{9)*} Power Master Reset is a setting needed to supply optimized power to the module control when multiple DVM CHILLERS are connected to the module control.

Chapter
03

Integrated Management System

DMS2.5

MIM-D01AUN 118

S-NET3

MST-P3P.....170

DMS2.5

MIM-D01AUN

Features

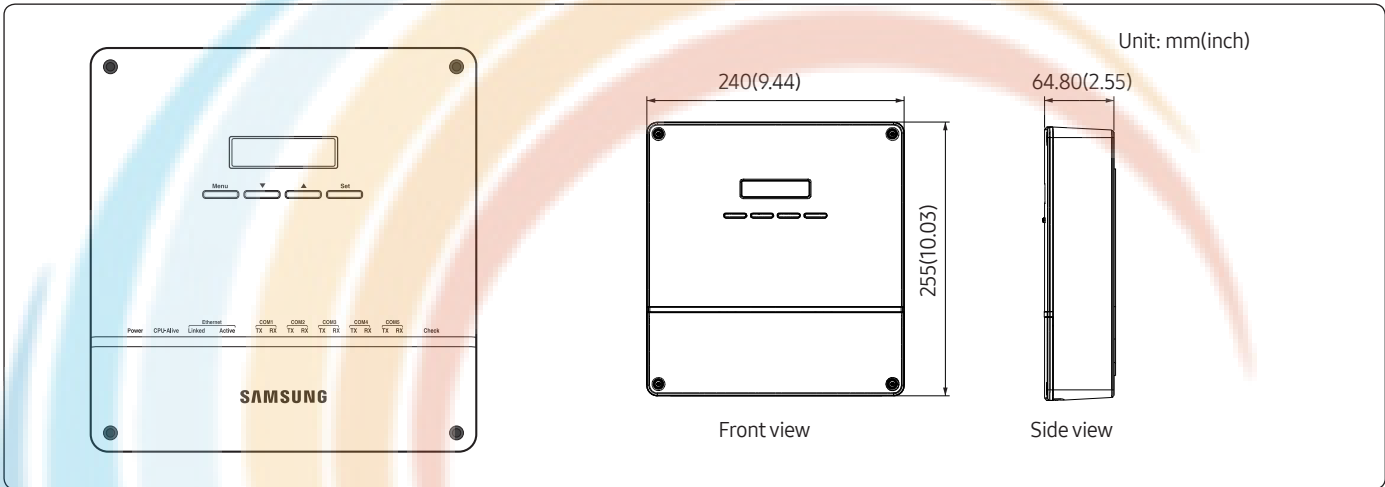

- Built-in web server for PC-independent management and remote access control
- Multiple upper-layer control access (S-NET 3, Web-client)
- Weekly/Daily schedule control
- Power distribution function
- Current time management even during power failure (for 24 hours)
- Emergency stop function with simple contact interface
- Individual/Group control of up to 256 indoor units and ERV, AHU, DVM CHILLER, FCU kit
- User editable control logic
- Accessible level management
- Dynamic security management
- Operation & error history management
- Data storage in non-volatile memory & SD memory

⚠ Caution

- You cannot upgrade DMS 2.0 to DMS2.5 by software upgrade.

Product specification

Power	Source	DC Adaptor		
	Input	100~240VAC (±10%), 50/60Hz		
	Output	12V 3A		
Operating temperature range		-10°C ~ 50°C (14°F~122°F)		
Operating humidity range		0%RH ~ 90%RH		
Communication method		<ul style="list-style-type: none"> • Lower level: RS485 x 5 • Upper level: Ethernet 100 Base-T x1 		
External connection port	Digital Output	8		
	Digital Input	10		
Maximum length of connection	RS485	1000 m (3280ft)		
	Digital Output	100 m (328ft)		
	Digital Input	100 m (328ft)		
	Ethernet	100 m (328ft): When there is no repeater		
Max. connectable number of device	Control layer	Device	Numbers per each channel	Total number for 5 channels
		Indoor units (including ERV, MCU, FCU KIT)	128	256
		Outdoor units (including MIM-N01, MIM-N10, MIM-F10N,DVM CHILLER unit)	16	80
		OnOff controller	Total 15 (Including Wi-Fi kit Max.4)	Total 75 (Including Wi-Fi kit Max.20)
		Touch centralized controller		
		Wi-Fi kit (MIM-H03UN)	8	8
PIM interface module (MIM-B16UN)	8	8		

Compatible product

Outdoor unit	AM****X*****, AC****X*****
Controller	OnOff controller (MCM-A202DUN)
	Touch centralized controller (MCM-A300UN)
	PIM interface module (MIM-B16UN)
	Wi-Fi kit (MIM-H03UN)

- Conventional communication outdoor unit requires interface module(MIM-N01).
- MIM-B13D, MIM-B13E, MIM-B04A Interface modules cannot be connected.
- To connect ERV, MIM-N10 is required.
- To connect FCU KIT, MIM-F10N is required.
- Conventional PIM must connect to CH4(COM5) of DMS 2.5.

Description of parts

Front

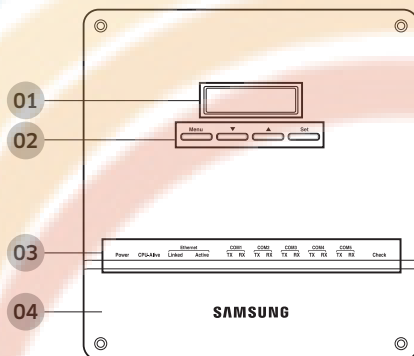

No.	Name	Function
01	LCD display	Shows current time and IP address. Various messages will be displayed depending on button input.
02	LCD operation button	There are 4 buttons (Menu, ▼(Down), ▲(Up), Set) and you can access to menu and move, check the menu.
03	LED Indicator	Check 15 LED status such as Power, CPU-Alive, Ethernet-Linked/Active, COM1~5-TX/RX and Check
04	DMS2.5 Bottom cover	Unfasten 2 screws on the bottom and separate the bottom cover from DMS2.5. Then check cable connection part.

LED indicator

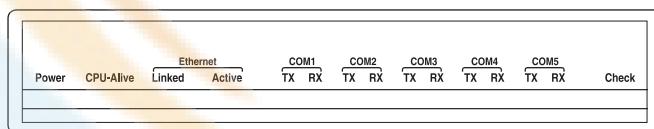

Item	Name	Status
Power	Power indicator	Turns blue when the power is supplied
CPU Alive	CPU operation indicator	Blinks in orange with 1 second intervals during normal operation
Ethernet - Linked	Internet connection indicator	Turns green during normal connection
Ethernet - Active	Internet data transmission/reception indicator	Blinks in orange during normal transmission/reception
COM1~5 - TX	OnOff controller/ Outdoor unit data transmission indicator	Blinks in green during normal transmission
COM1~5 - RX	OnOff controller/ Outdoor unit data reception indicator	Blinks in green during normal reception
Check	Indoor/outdoor unit/error check indicator	Turns green when there is an error on more than one indoor/outdoor unit or in communication

Bottom

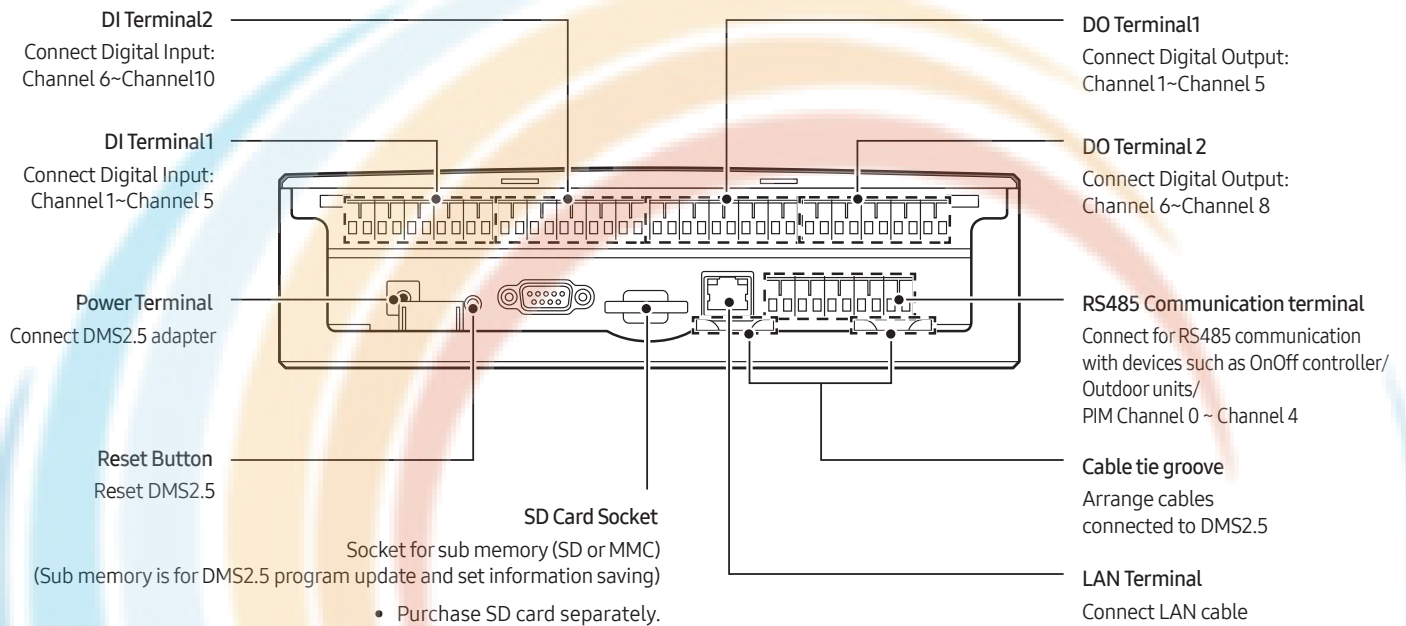

Menu and display

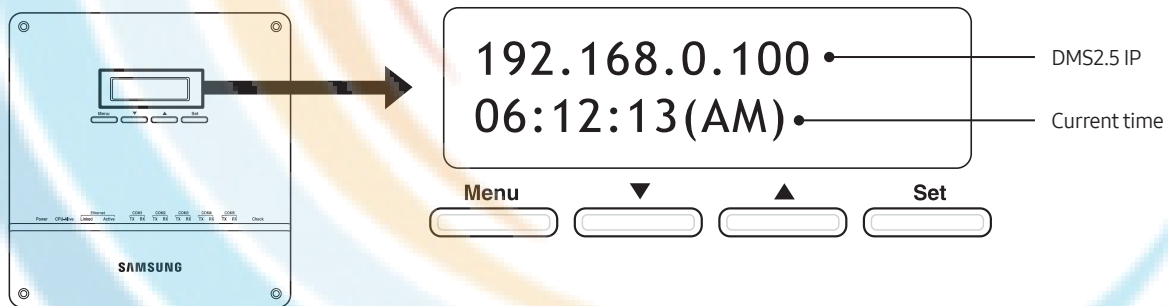

Button	Detail description
LCD display	<ul style="list-style-type: none"> • General display: Displays IP address of the DMS2.5 and current time • In Menu: Displays menu information and set value
Menu 	<ul style="list-style-type: none"> • Access menu and select main menu • Cancel menu setting
	<ul style="list-style-type: none"> • Move between menu • Change the menu settings
	<ul style="list-style-type: none"> • Move between menu • Change the menu settings
Set 	<ul style="list-style-type: none"> • Access sub menu • Save the change of menu settings

Connection diagram

MIM-B16UN(PIM) can be connected with outdoor units or controllers to same channel of DMS2.5.

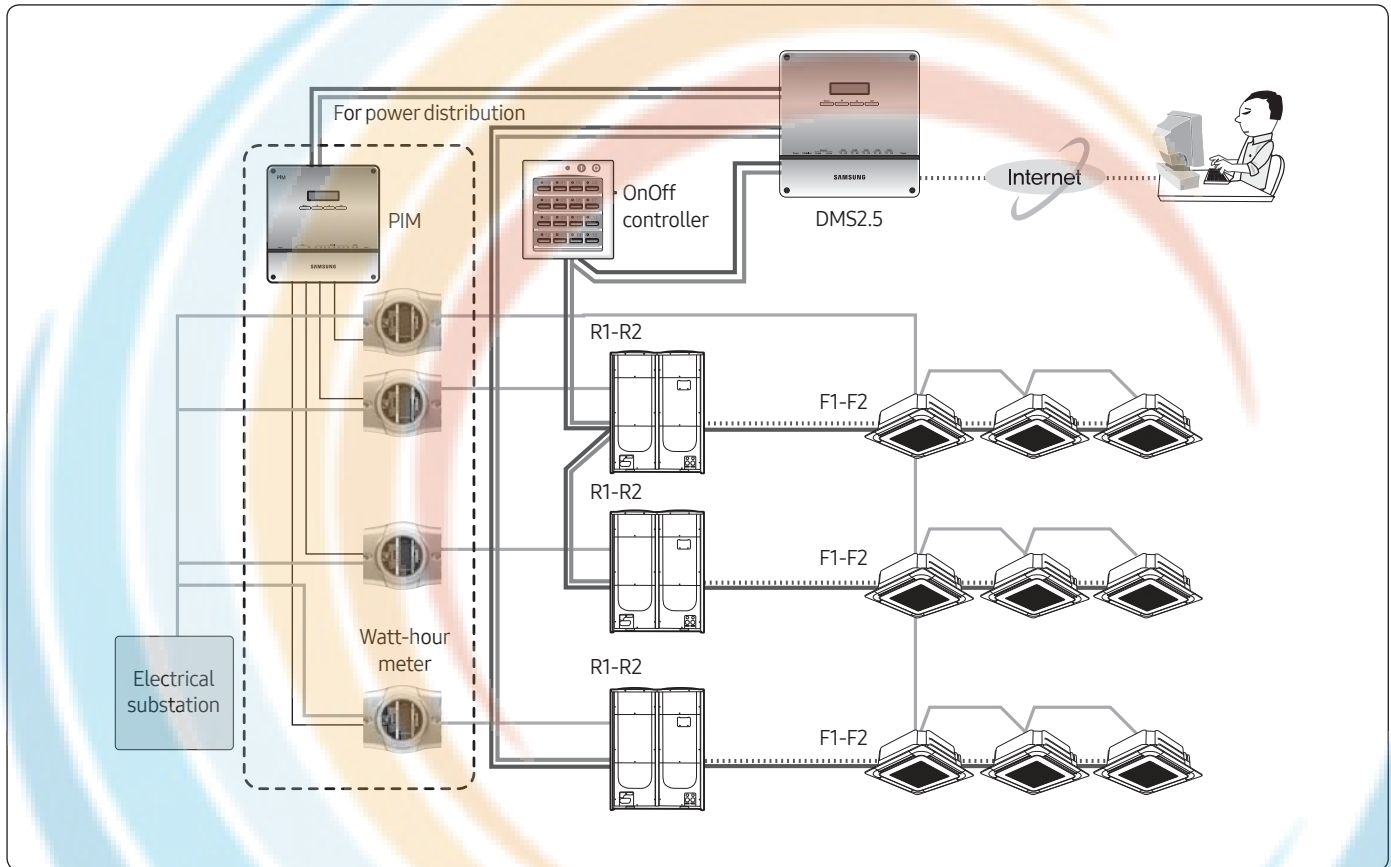

Wiring

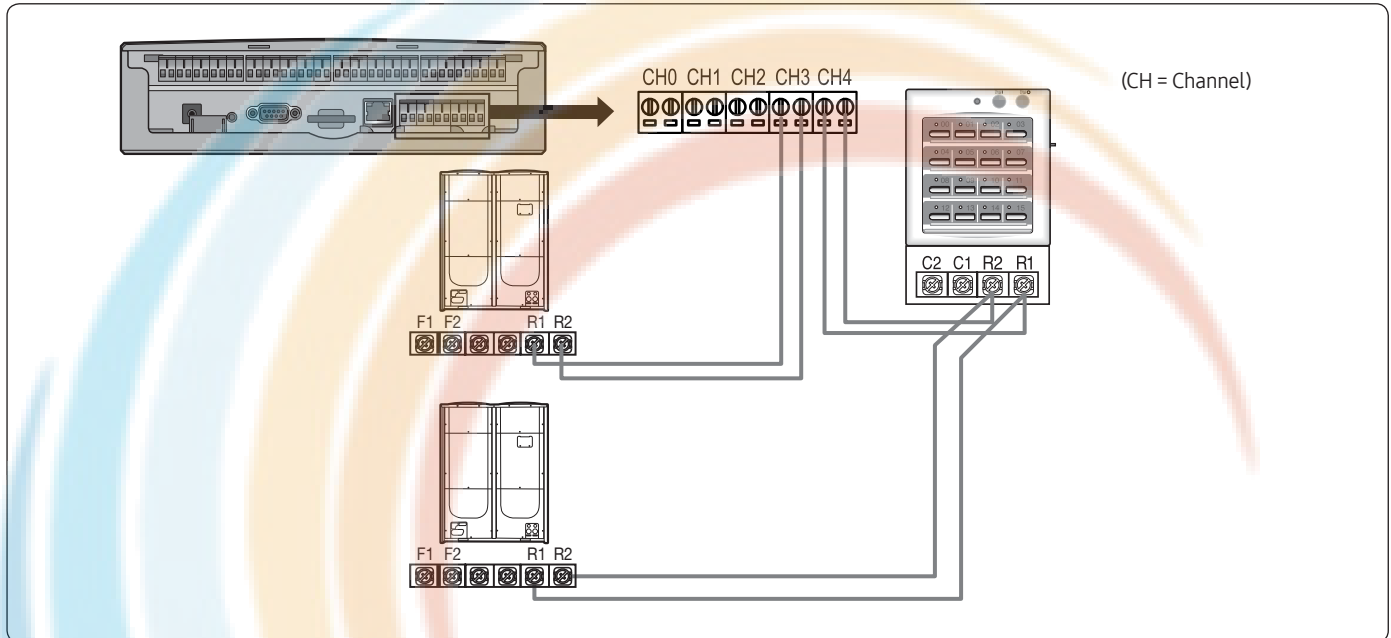

Connecting outdoor unit directly

- Maximum 16 outdoor units can be connected to each channel
- Total 80 outdoor units can be connected

Connecting OnOff controller/Touch centralized controller

- Maximum 15 OnOff controller/Touch centralized controller can be connected to each channel

Note

- DMS2.5 can connect outdoor unit and OnOff controller/Touch centralized controller at the same time.
- Outdoor unit and OnOff controller/Touch centralized controller can be connected to 1 communication channel at the same time.

Connecting with outdoor unit

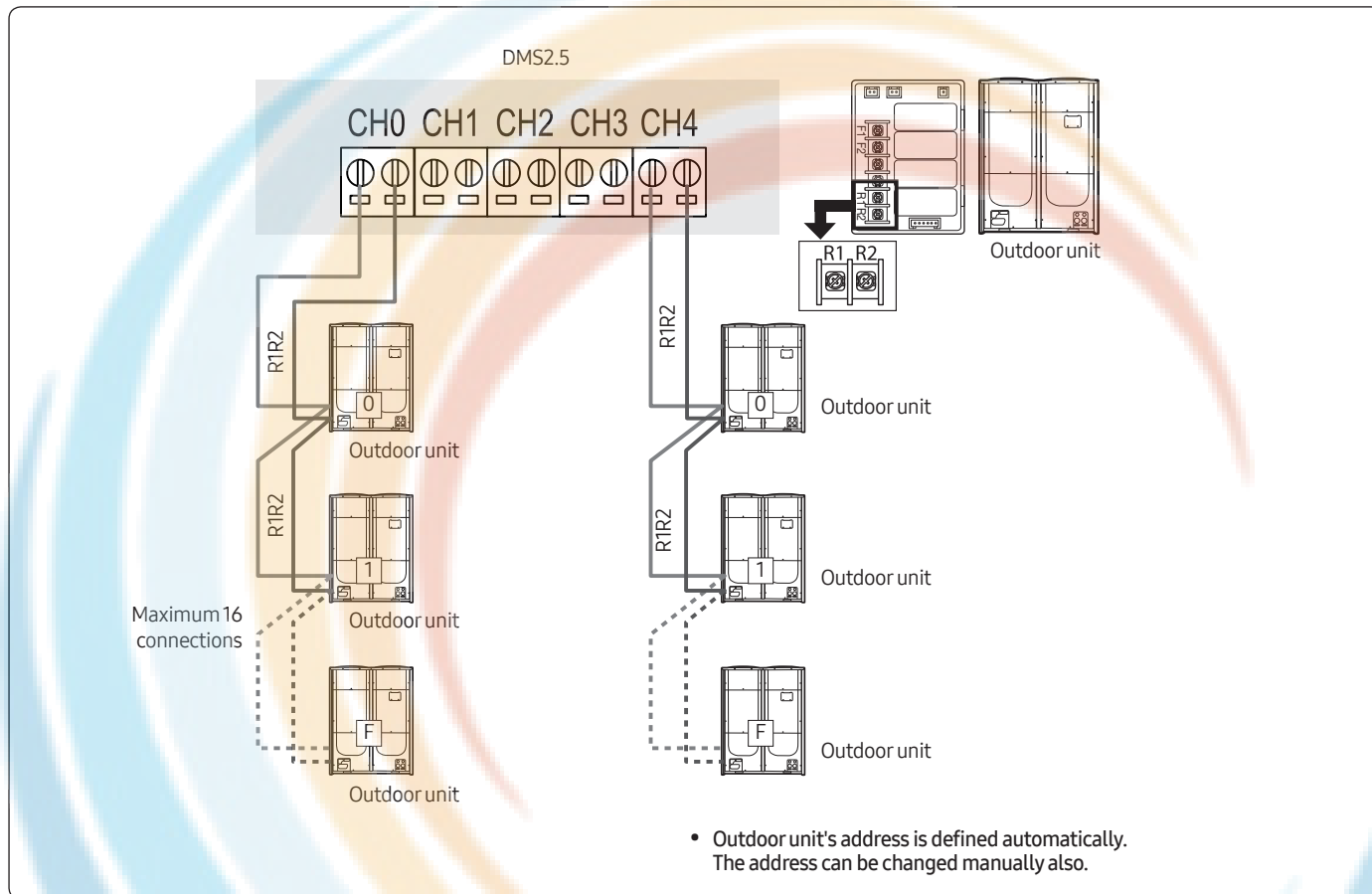

Connecting with OnOff controller/Touch centralized controller

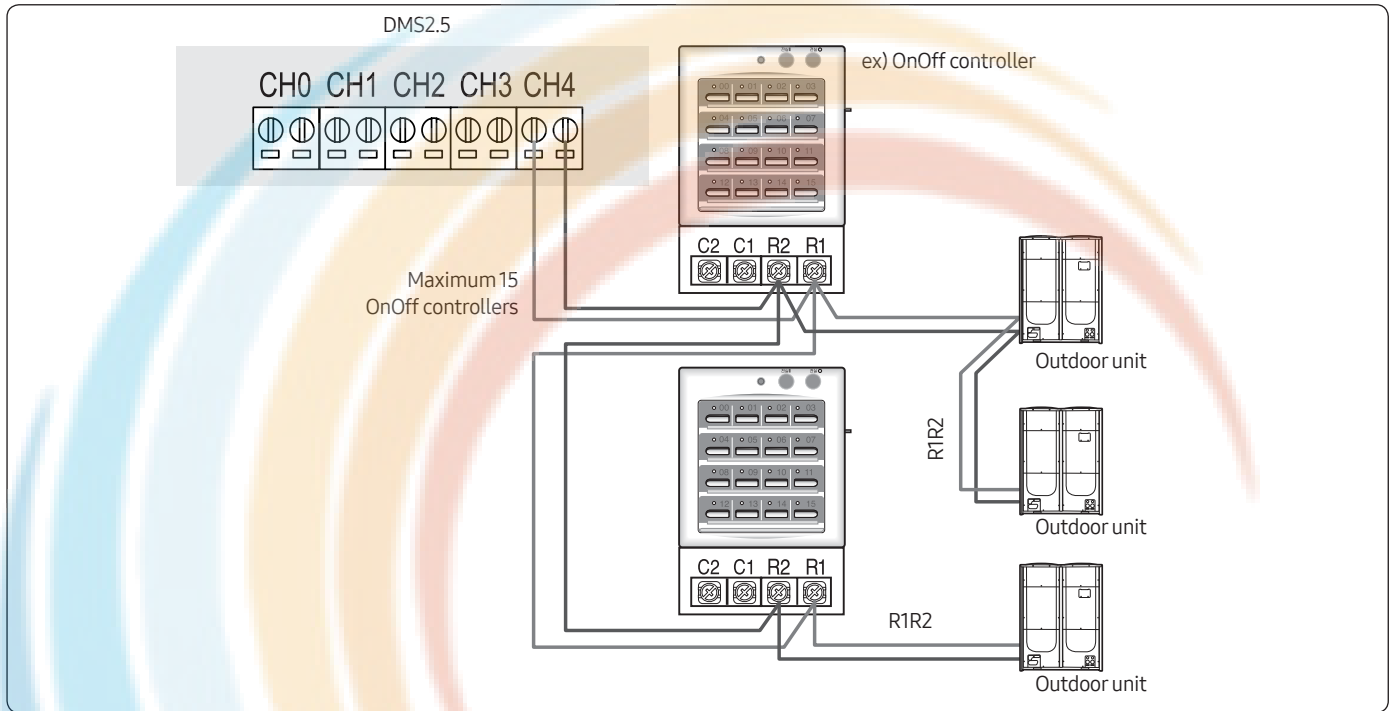

Connecting with outdoor unit and OnOff controller/Touch centralized controller

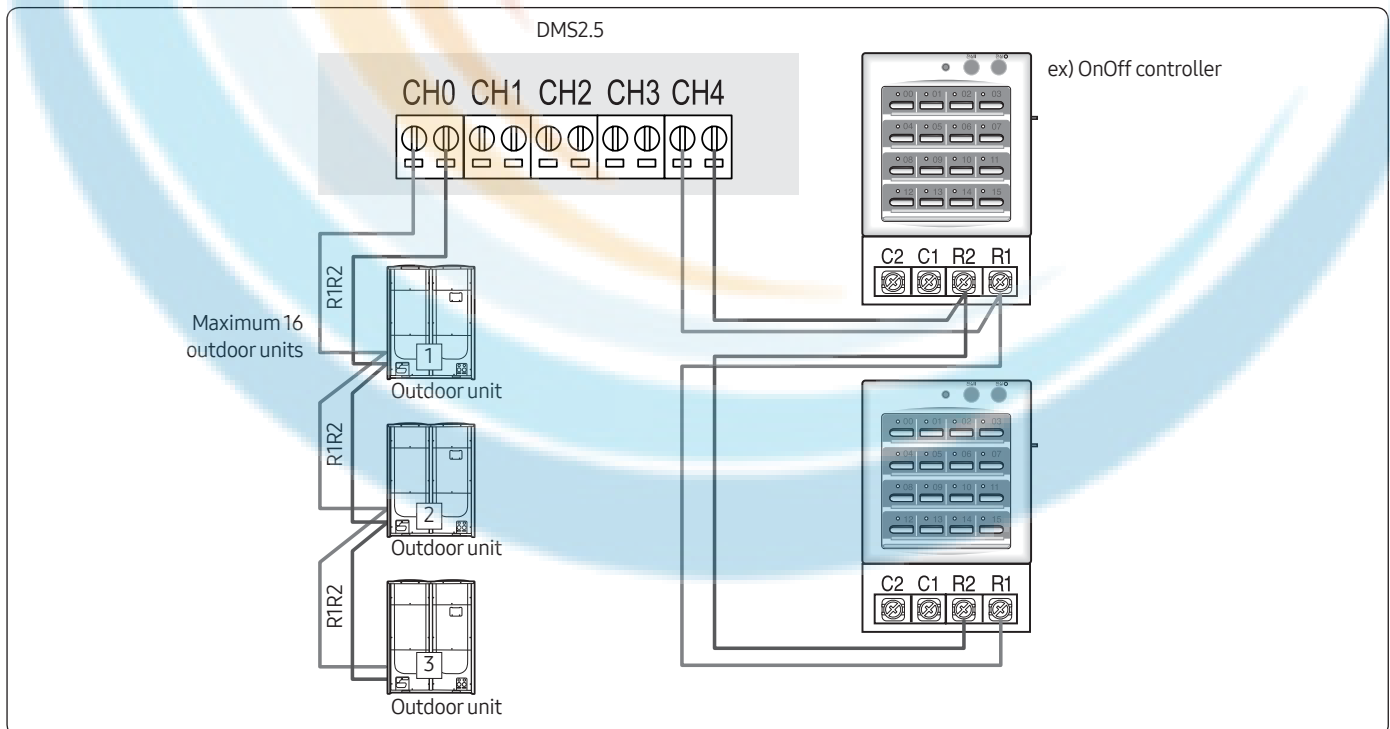

Wiring distance

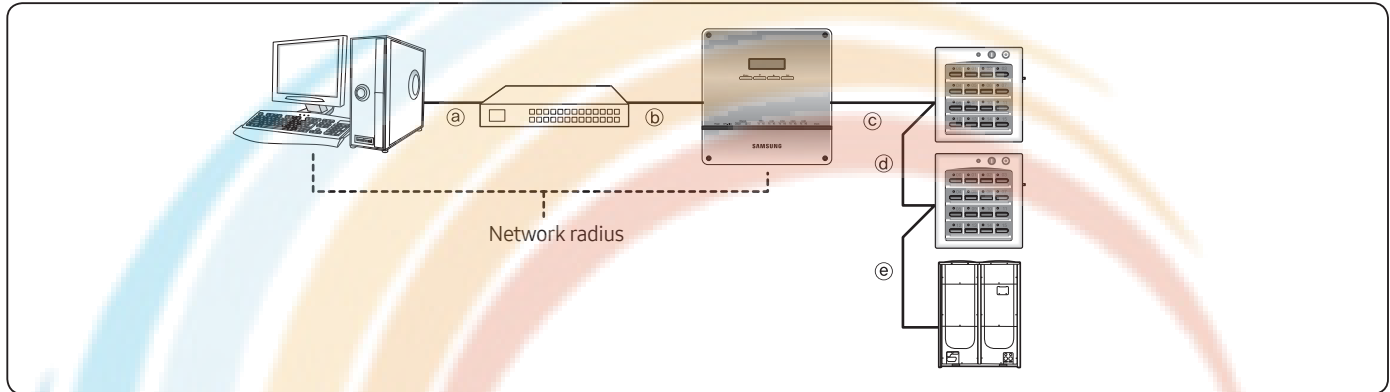

- Distance between DMS2.5 and OnOff controller/Touch centralized controller/outdoor unit
 - Distance from the DMS2.5 to the furthest device cannot exceed 1000m(3280ft).
 - © + @ + © ≤ 1000m
- Distance between DMS2.5 and upper level controller
 - Since DMS2.5 supports 100 Base-T Ethernet, first repeater or upper level controller from the DMS2.5 cannot be further than 100m(328ft) (IEEE 802.3). Therefore, maximum network radius is restricted to 500m(1640ft).

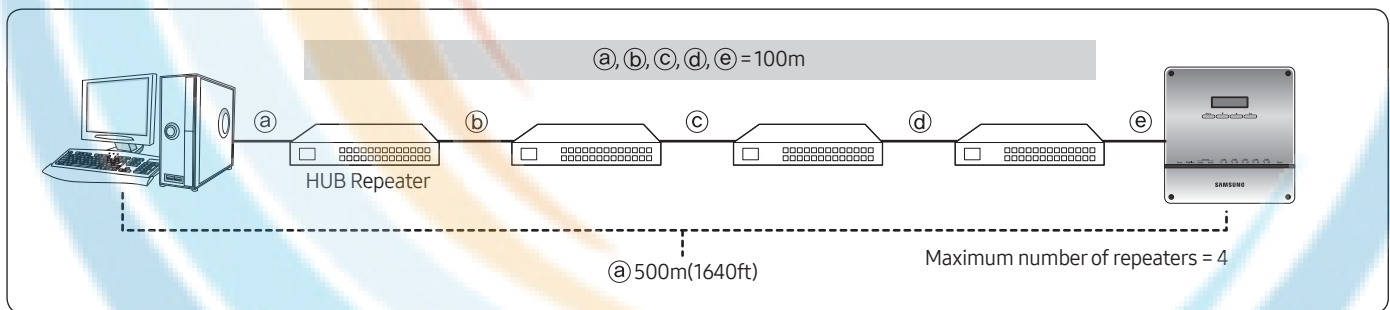

Function

Tracking

Tracking is an operation that finds devices which are connected to DMS2.5. Through tracking operation, devices which are connected to DMS2.5 can recognize if they are connecting to DMS2.5. To supervise and control system air conditioner using DMS2.5, tracking should be done first.

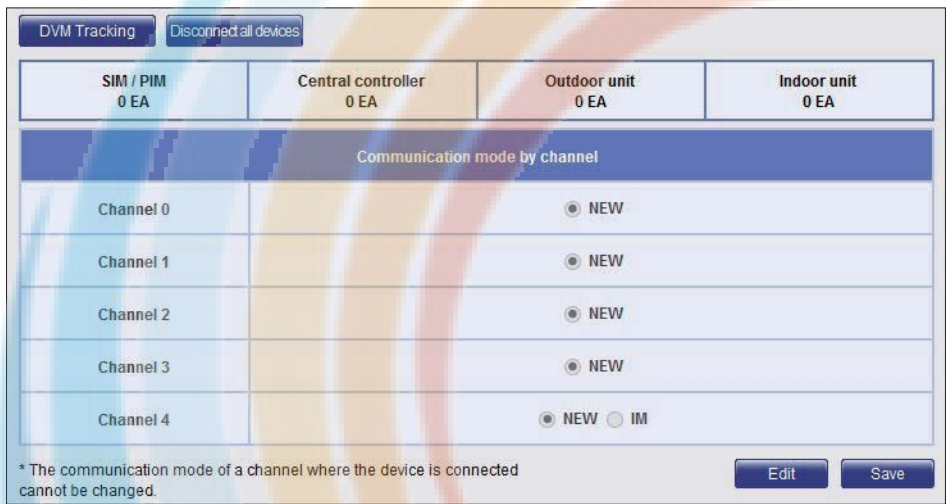

- When outdoor unit or controller is connected to channel, set as “NEW”
- IM mode cannot be set, but it can be used for function change or new function with an updated version.

You can check the number of installed devices, address of the devices or rename the indoor unit after tracking is completed.

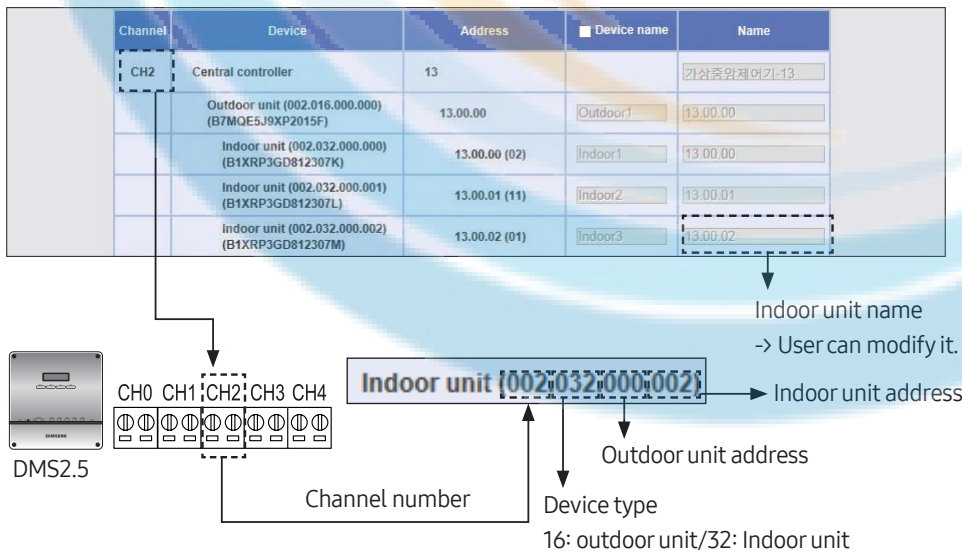

Control & monitoring

DMS2.5 can control and monitor Max 256 devices. (Indoor unit, ERV, AHU, DVM Chiller, FCU Kit, Packaged DOAS)
 And it also controls and monitors external contact point (8 Digital input, 6 Digital output.)

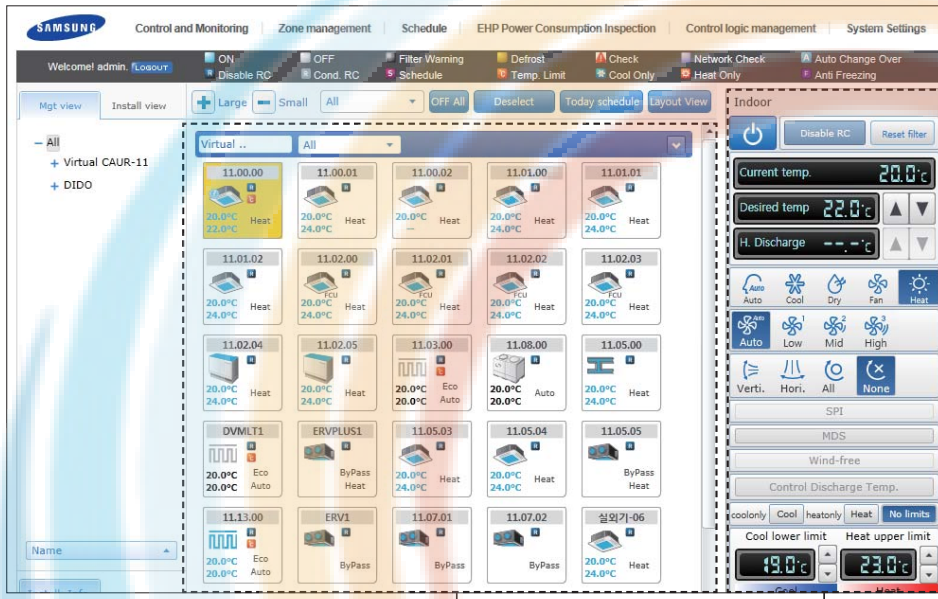

Monitoring ←
 Indoor unit, ERV, AHU
 External contact point

Control ←
 Variable web remote controllers
 depends on device type.

Multiple language support

DMS2.5 (MIM-D01AUN) supports 15 languages

Select Language		
<input type="radio"/> 한국어	<input type="radio"/> 中文	<input type="radio"/> Nederlands
<input checked="" type="radio"/> English	<input type="radio"/> Français	<input type="radio"/> Ελληνικά
<input type="radio"/> Magyar	<input type="radio"/> Italiano	<input type="radio"/> Polski
<input type="radio"/> Português	<input type="radio"/> Slovensky	<input type="radio"/> Español
<input type="radio"/> Deutsch	<input type="radio"/> русский	<input type="radio"/> Türkçe

2D Layout view

DMS2.5 supports control and monitoring based on 2D Layout.

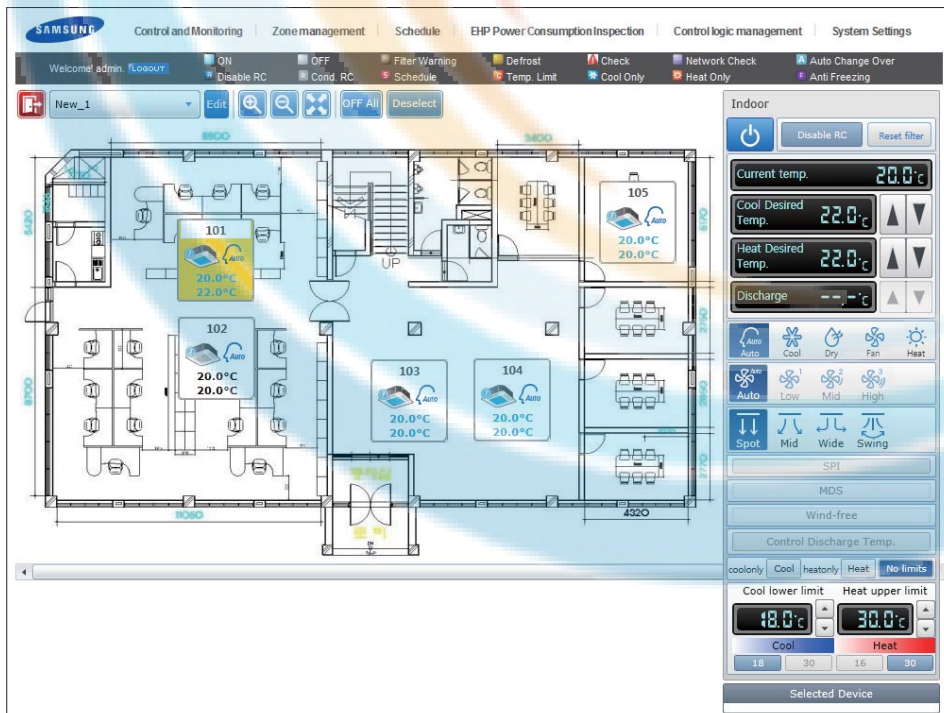

Set silent control

DMS2.5(MIM-D01AUN) can control indoor unit without operation beeping sound using below setting option.

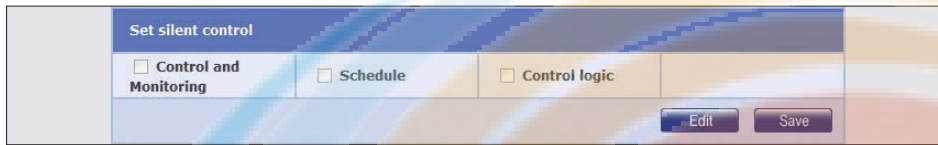

- Control and Monitoring: Select this if you want to control silently in 'Control and Monitoring' screen of DMS2.5.
- Schedule: Select this if you want to perform 'Schedule' silently.
- Control logic: Select this if you want to perform 'Control logic' silently.

OnOff controller restriction

DMS2.5 (MIM-D01AUN) can restrict OnOff controller, Touch centralized controller usage.

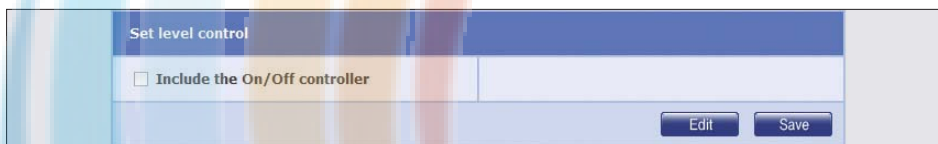

- Select this if you want to restrict controlling from OnOff controller and Touch centralized controller when you disable RC from the DMS2.5.

Contact point control

You can select emergency operation pattern

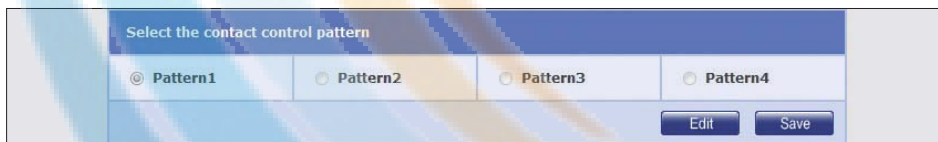

Pattern 2

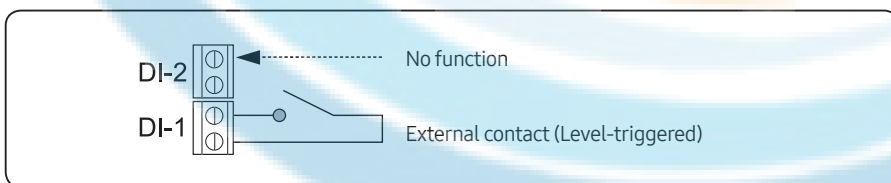

Short external contact: Emergency stop

- Turns off all the indoor units when there is an ON signal input
- All the remote control use is disabled
- Control from S-NET3 is unavailable
- Disable schedule control

Open external contact: Resume operation

- After Emergency stop, the indoor units stay in the current OFF states.
- All the remote control use is restored to the previous state.
- Schedule control is enabled again.

Pattern 3

Schedule control is not interrupted in Pattern 3.

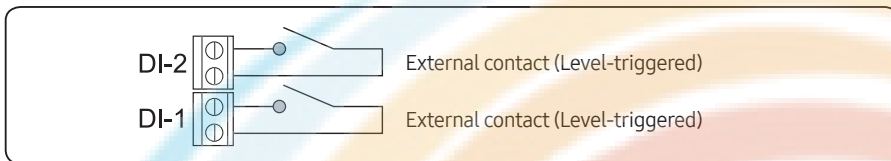

External contact input to DI-1

- Short contact: Starts all indoor unit operation.
- Open contact: Stops all indoor unit operation.

External contact input to DI-2

- Short contact: Disables the use of all wired/ wireless remote controllers.
- Open contact: Enables the use of all wired/ wireless remote controllers.

Pattern 4

Schedule control is not interrupted in Pattern 4.

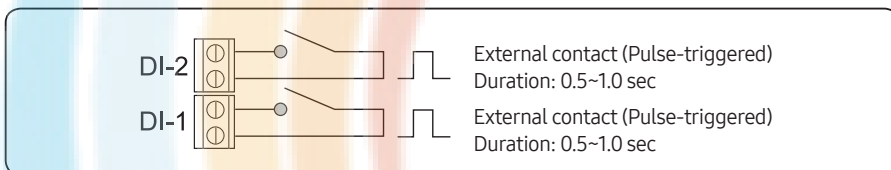

External contact pulse input to DI-1

- Short pulse-triggered: Starts all indoor unit operation.

External contact pulse input to DI-2

- Short pulse-triggered: Stops all indoor unit operation.

General external contact point control

DMS2.5 has Digital input/output ports to check the external device status or turn them On/Off through contact point.

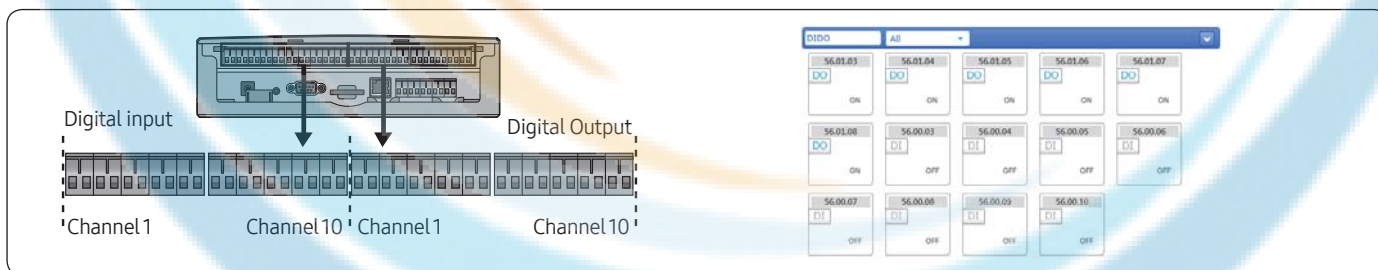

DI: Voltage free contact signal input (Open/Short)

- Channel 1, Channel 2 is occupied with [Emergency stop] function.
- Channel 3~Channel 10: DMS2.5 can monitor the contact signal input state of each channel

DO: Contact signal output (DC12V)

- Channel 1, Channel 2, Channel 9 and Channel 10 is occupied with other functions.
- Channel 3~Channel 8: DMS2.5 can control contact signal output.

Note

- DI 1, 2/DO 1, 2, 9, 10 will be excluded from control and monitoring since it is being used by internal function of DMS2.5.

Time sync with the wired remote control

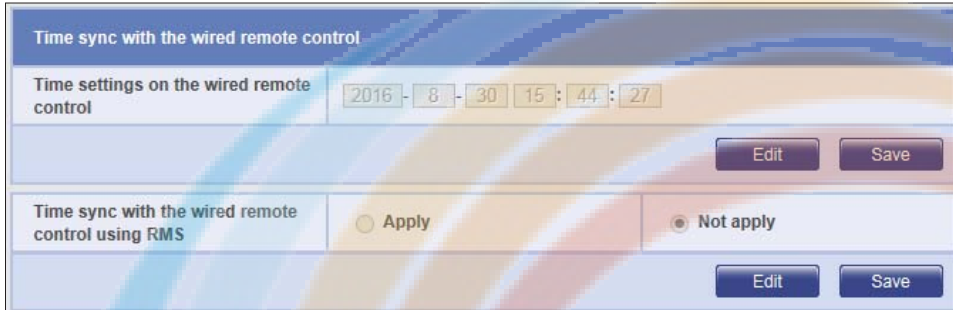

- 1 Click [System Settings] → [System environment setting] when DMS2.5 web page menu screen appears.
- 2 Click [Edit] on [Time settings on the wired remote control] in [Time sync with the wired remote control] menu.
 - Set the time to use.
- 3 Click [Edit] on [Time sync with the wired remote control using RMS] in [Time sync with the wired remote control] menu and click [Apply].
 - Be sure to click [Apply] to start auto sync through RMS service.
- 4 Click [Save].

Synchronizing time via the Internet

- 1 Set this function when you synchronize the time of DMS with an Internet time server.
 - This function operates properly only when DMS is installed so that it can connect to the Internet.
- 2 Click [Apply], and then set the time offset based on the Universal Time Coordinated (UTC) for the place where DMS is installed.

Activating [Daylight Saving Time Setting]

- 1 Click [System Settings] → [System environment setting] when DMS2.5 web page menu screen appears.
- 2 Click [Edit] on [Daylight Saving Time Setting].
- 3 Set the Start date and End date after selecting Apply.
- 4 Click [Save].

Note

- Time setting is available only in some wired remote controllers that can support time setting function through the DMS.
- You can use the auto time sync function of the wired remote controller through the RMS only while using the RMS service. The time for the wired remote controller is automatically set based on the RMS time once a day.

Indoor unit usage restriction

- Operation limit: To prevent the wrong operation mode setting, it can limit the operation mode of indoor unit.
- Temperature limit: It can set the upper and lower temperature limit in Cool/Heat mode.

Indoor unit usage restriction						
Address	Name	Limit mode	Control mode	Cooling temperature		Heating temperature
11.00.00(255)	11.00.00	None	None	Lower limit 18.0 °C	Upper limit 30.0 °C	Lower limit 16.0 °C Upper limit 30.0 °C
11.00.01(255)	11.00.01	Cool Only	None	Lower limit 18.0 °C	Upper limit 30.0 °C	Lower limit 16.0 °C Upper limit 30.0 °C
11.00.02(255)	11.00.02	None	None	Lower limit 18.0 °C	Upper limit 30.0 °C	Lower limit 16.0 °C Upper limit 30.0 °C
11.00.03(255)	11.00.03	None	None	Lower limit 18.0 °C	Upper limit 30.0 °C	Lower limit 16.0 °C Upper limit 30.0 °C

- 01 Indoor unit address
- 02 Operation mode restriction
- 03 Control mode
- 04 Setting Upper and Lower temperature limit in Heating/Cooling

1 Check the indoor unit address.

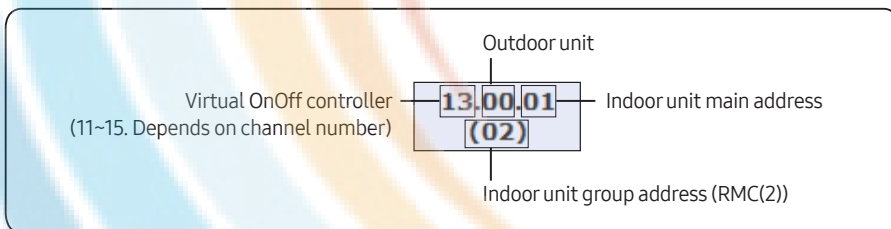

2 Select the Limit mode

- Indoor units within same outdoor unit must be set in same limit mode.
- All indoor units of one outdoor unit set same operation mode restriction automatically.

3 Control mode will be set automatically depends on the selected restricted mode

- Ex) When the restricted mode is set to [Cool-only] and then [Control mode] is set to [Cool] automatically
 If user set [Heating mode] using remote controller → Indoor unit ignores the command.

4 Set the Upper and Lower temperature limit in Heating/Cooling.

- Upper and Lower temperature limit in Heating/Cooling can be set differently for each indoor unit. [Cooling:18°C~30 °C (64°F~86°F), Heating:16 °C~30 °C (61°F~86°F)]

Logic control

What is logic control?

User can control the air conditioner, ERV, AHU and digital output depending on the conditions, such as room temperature and outdoor temperature, set by the user. Input condition can be used with parameter and it will be calculated with arithmetic equation. Schedule function executes operation by time but logic control executes operation according to the conditions that set by the user.

Examples of utilizing the logic control

- Case 1) Government regulates the lowest room temperature to be 26°C (78°F) in public places. When the room temperature is lower than 26°C (78°F), administrator must turn off all the air conditioners in the area. Is there any way for the air conditioner to turn off automatically depending on the certain room temperature?
- Case 2) During spring and fall, it is cold in the morning and warm in the afternoon. Therefore, I'm using the air conditioner in heating mode in the morning and depending on the outdoor temperature?
- Case 3) I'm using air conditioner with ERV. In the days with the outdoor temperature relatively lower than the indoor, I want to use ERV instead of the air conditioner to ventilate and minimize the air conditioner use. Is there any way to set the air conditioner or ERV to operate appropriately and automatically depending on the temperature?

Input

- 1** Select the factor to input condition
 - Device, factor
- 2** Edit the condition
 - Compound factor/Comparison operator
 - Standard value/Duration

Output

- 1** Select output factor
 - Device, factor
- 2** Edit output
 - Create control

Edit factor			Compound factor	Comparison operator	Command
Single factor	Power		AND	=	Power
	Current temp.				Desired temp.
Arithmetic factor	Outdoor temp.		OR	=>	Mode
	Mode				Fan speed
	Fan speed				Air swing
	Air flow				Enable/Disable RC
Function factor	Enable/Disable RC			=<	Limit mode
	Trouble, Limit mode				
Arithmetic factor	+			>	Current temp.
	-				Desired temp.
Function factor	Average			<	Outdoor temp.
					Current temp.
				≠	Desired temp.
					Outdoor temp.

Type	Item	Value	Remarks
Outdoor unit	Current electric control option	50%, 55%, 60%, 65%, 70%, 75%, 80%, 85%, 90%, 95%, 100%	Control impossible
	Current heating capacity calibration	25kg/cm ² , 26kg/cm ² , 27kg/cm ² , 28kg/cm ² , 29kg/cm ² , 30kg/cm ² , 31kg/cm ² , 32kg/cm ² , 33kg/cm ²	Control impossible
	Current cooling capacity calibration	5~7°C(41~45°F), 7~9°C(45~48°F), 9~11°C(48~52°F), 10~12°C(50~54°F), 11~13°C(52~55°F), 12~14°C(54~57°F), 13~15°C(55~59°F)	Control impossible
	Electric control option	50%, 55%, 60%, 65%, 70%, 75%, 80%, 85%, 90%, 95%, 100%	
	Heating capacity calibration	25kg/cm ² , 26kg/cm ² , 27kg/cm ² , 28kg/cm ² , 29kg/cm ² , 30kg/cm ² , 31kg/cm ² , 32kg/cm ² , 33kg/cm ²	
	Cooling capacity calibration	5~7°C(41~45°F), 7~9°C(45~48°F), 9~11°C(48~52°F), 10~12°C(50~54°F), 11~13°C(52~55°F), 12~14°C(54~57°F), 13~15°C(55~59°F)	
	Error detection	True, False	Control impossible
	Limit operation mode	None, Cool only, Heat only	-
	Power	On, Off	-
	Current temp.	Number	Control impossible
Indoor unit	Desired temp.	Number	-
	Outdoor temp.	Number	Control impossible
	Operation mode	Auto, Cool, Dry, Fan, Heat	-
	Fan speed	Auto, Low, Mid, High	Turbo is available when the device supports the Turbo fan speed.
	Air direction	Vertical, Horizontal, All, None	-

Type	Item	Value	Remarks
ERV	RC usage	Enable RC, Disable RC, Cond. RC	-
	Error detection	True, False	Control impossible
	Limit operation mode	None, Cool only, Heat only	-
	Power	On, Off	-
	Operation mode	Auto, HeatEx, Bypass, Sleep	-
	Fan speed	Low, High, Turbo	-
	RC usage	Enable RC, Disable RC, Cond. RC	-
	Error detection	True, False	Control impossible
	Limit operation mode	None, Cool only, Heat only	-
	Power	On, Off	-
ERV PLUS	Outdoor temp.	Number	Control impossible
	ERV mode	Auto, HeatEX, Bypass, Sleep	-
	ERV fan speed	Low, High, Turbo	-
	Operation mode	Auto, Cool, Heat, Off	-
	RC usage	Enable RC, Disable RC, Cond. RC	-
	Error detection	True, False	Control impossible
	Limit operation mode	None, Cool only, Heat only	-
	Power	On, Off	-
	Operation mode	Auto, Cool, Fan, Heat	-
	OA intake temp.	Number	Control impossible
Fresh duct	Outdoor temperature	Number	Control impossible
	Cool discharge temp.	Number	-
	Heat discharge temp.	Number	-
	RC usage	Enable RC, Disable RC, Cond. RC	-
	Power	On, Off	-
	Error detection	True, False	Control impossible
	Limit operation mode	None, Cool only, Heat only	-

Type	Item	Value	Remarks
AHU	Current temp.	Number	Control impossible
	Desired temp.	Number	-
	Outdoor temp.	Number	Control impossible
	Operation mode	Auto, Cool, Dry, Fan, Heat	-
	RC usage	Enable RC, Disable RC, Cond. RC	-
	Power	On, Off	-
	Error detection	True, False	Control impossible
	Limit operation mode	None, Cool only, Heat only	-
DI	Status	On, Off	Control impossible
	Error detection	True, False	Control impossible
	Limit operation mode	None, Cool only, Heat only	-
DO	Status	On, Off	-
	Error detection	True, False	Control impossible
	Limit operation mode	None, Cool only, Heat only	-
Hydro Unit, Hydro Unit HT, Single EHS	Status	On, Off	Control impossible
	Status	On, Off	-
	Power	On, Off	-
	Current temp.	Number	Control impossible
	Desired temp.	Number	-
	Current water out temp.	Number	Control impossible
	Desired water out temp.	Number	-
Outdoor temp.	Number	Control impossible	

Type	Item	Value	Remarks
Hydro Unit, Hydro Unit HT, Single EHS	Operation mode	Auto, Cool, Heat	Hydro unit HT cannot set Cool mode
	DHW power	On, Off	-
	Current DHW temp.	Number	Control impossible
	Desired water out temp.	Number	-
	DHW mode	Eco, Standard, Power, Force	'Force' is only for Single EHS
	RC usage	Enable RC, Disable RC, Cond. RC	-
	Error detection	True, False	Control impossible
	Limit operation mode	None, Cool only, Heat only	-
	Power	On, Off	-
	DVM CHILLER	Current temp.	Number
Desired temp.		Number	-
Outdoor temp.		Number	Control impossible
Operation mode		Cool, Cool Storage, Heat, Hot Water	-
RC usage		Enable RC, Disable RC, Cond. RC	-
Error detection		True, False	Control impossible
FCU Kit	Power	On, Off	-
	Current temp.	Number	Control impossible
	Desired temp.	Number	-
	Operation mode	Auto, Cool, Fan, Heat	-
	Fan speed	Auto, Low, Mid, High	-
	RC usage	Enable RC, Disable RC, Cond. RC	-
	Error detection	True, False	Control impossible
	Limit operation mode	None, Cool only, Heat only	-

Editing input factor

The screenshot shows the 'Setting control logic' interface. It includes fields for Name, Period (2016-2017), Day (Sun-Sat), and Time (0-24). The 'Factor edit' is set to 'Single'. A 'Device selection' pop-up window is open, showing a list of devices with addresses and names. The 'Input' section has three rows for compound factors, each with a 'Select a factor' button, a 'Comparison operator' dropdown, a 'Standard value' dropdown, and a 'Duration (minute)' dropdown.

- 01 Click "Select a factor". ▶
- 02 Select type of the factor ▶
- 03 Click "Select a device" ▶
- 04 Select the device from the list. ▶
- 05 Select a detail item ▶
- 06 Click "Apply". ▶
- 07 Select the comparison operator ▶
- 08 Select a standard value ▶
- 09 Select the duration ▶

- Single factor: 1 device and 1 factor.

The screenshot shows the 'Factor edit' interface for a single factor. The 'Factor edit' dropdown is set to 'Single'. The 'Device' dropdown is set to '12.00.00 Power'.

- Arithmetic: It means 2 devices are connected by arithmetic operator.

The screenshot shows the 'Factor edit' interface for an arithmetic factor. The 'Factor edit' dropdown is set to 'Arithmetic'. It shows two devices: '12.00.00 Current temperature' and '12.00.01 Current temperature' connected by an arithmetic operator.

- Function: Use average value of various conditions from the device and create it as a factor.

The screenshot shows the 'Factor edit' interface for a function factor. The 'Factor edit' dropdown is set to 'Function'. It shows five devices: '12.00.00 Current temperature', '12.00.01 Current temperature', '12.00.02 Current temperature', '12.01.00 Current temperature', and '12.01.01 Current temperature' connected by a function operator.

<input type="checkbox"/>	Compound factor	Factor	Comparison operator	Standard value	Duration (minute)
<input type="checkbox"/>		12.00.00.Desired temp.	=	<input type="radio"/> <input type="text"/> <input type="radio"/> Select a factor	<input checked="" type="radio"/> Cancel <input type="radio"/> Apply 1
<input type="checkbox"/>	AND OR	Select a factor	=	<input checked="" type="radio"/> None <input type="radio"/> Select a factor	<input checked="" type="radio"/> Cancel <input type="radio"/> Apply 1
<input type="checkbox"/>	AND	Select a factor	=	<input checked="" type="radio"/> None <input type="radio"/> Select a factor	<input checked="" type="radio"/> Cancel <input type="radio"/> Apply 1

- Compound factor: AND, OR, No selection
 Ex) Apply 'AND' or 'OR' to 3 factors → (input 1) AND (input 2) OR (input 3)
- Comparison operator: =, =>, =<, >, <, ≠
- Standard value: Standard value of the factor
 Ex) When the factor is "Outdoor temperature of the indoor unit number 00", then standard value is value of the "Outdoor temperature". → "Outdoor temperature of the indoor unit number 00" > 20
- Duration: Duration can be set between 1~60 min.

Item	Comparison operator	Standard value
Power	=, ≠	On, Off
Current temp	=, =>, =<, >, <, ≠	Temperature value (number)
Desired temp	=, =>, =<, >, <, ≠	Temperature value (number)
Outside temp	=, =>, =<, >, <, ≠	Temperature value (number)
Mode	=, ≠	Auto, Cool, Dry, Fan, Heat
Fan speed	=, ≠	Auto, Low, Med, High
Air flow	=, ≠	Vertical, Horizontal, All, None
Enable RC	=, ≠	ON, OFF, Level 1
Trouble	=, ≠	True, False
Limit mode	=, ≠	None, Cool Only, Heat Only

Editing output factor

Setting control logic

Name:

Period: 2016 | 8 | 30 | 2017 | 8

Day: Sun Mon Tue Wed Thu Fri Sat

Time: 0 | 0 | 24 | 0

Factor edit: **Single**

Only 'Single' will be listed

Device: **Select**

12.02 Power

04 Current temp.

Desired temp.

Outdoor temp.

Mode

Fan speed

Air flow

Enable RC

* Click 'Select' button : a pop-up window appears and you can select a device
 "Current temp." and "Outdoor temp." cannot be selected

Device selection

Address	Name
12.00	12.00.00
12.01	12.01.00
12.00.00	12.00.00
12.00.01	12.00.01
12.00.02	12.00.02
12.01.00	12.01.00
12.01.01	12.01.01
12.01.02	12.01.02
56.00.03	56.00.03
56.00.04	56.00.04
56.00.05	56.00.05

05 Apply

Output

Factor	Command
01 Select a factor	06 <input checked="" type="radio"/> None <input type="radio"/> Select a factor
Select a factor	<input checked="" type="radio"/> None <input type="radio"/> Select a factor
Select a factor	<input checked="" type="radio"/> None <input type="radio"/> Select a factor

07 Save

Add Delete

- 01 Click "Select a factor". ▶
- 02 Click "Select a device". ▶
- 03 Select the device from the list. ▶
- 04 Select a detail item to control. ▶
- 05 Click "Apply". ▶
- 06 Select "Command". ▶
- 07 Click "Save".

Control example – Setting

Ex) Set the ERV to turn off together when the indoor unit turns off

- 1 Click [Control logic management] → [Setting control logic] from DMS2.5 menu.
 Click [Register] to create new control logic.

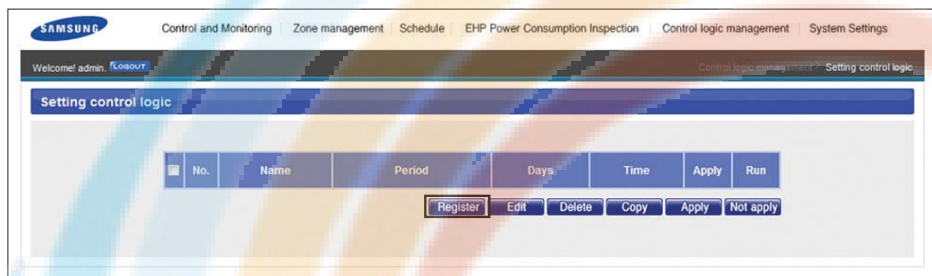

- 2 Enter Name, period/day and time for new control logic.

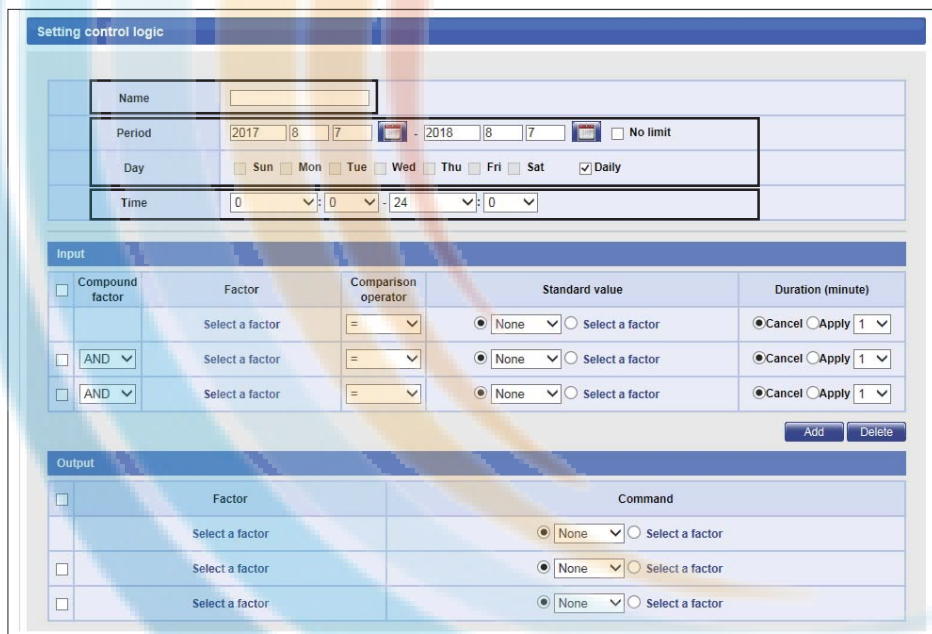

3 Create input condition: Click [Select a factor] from the 'Input' window.

Compound factor	Factor	Comparison operator	Standard value	Duration (minute)
<input type="checkbox"/>	Select a factor	=	<input checked="" type="radio"/> None <input type="radio"/> Select a factor	<input checked="" type="radio"/> Cancel <input type="radio"/> Apply 1
<input type="checkbox"/> AND	Select a factor	=	<input checked="" type="radio"/> None <input type="radio"/> Select a factor	<input checked="" type="radio"/> Cancel <input type="radio"/> Apply 1
<input type="checkbox"/> AND	Select a factor	=	<input checked="" type="radio"/> None <input type="radio"/> Select a factor	<input checked="" type="radio"/> Cancel <input type="radio"/> Apply 1

4 Click [Select], then [Device selection] window will pop up. Select a indoor unit to apply the new control logic.

Address	Name
12.00	12.00.00
12.01	12.01.00
12.00.00	12.00.00
12.00.01	12.00.01
12.00.02	12.00.02
12.01.00	12.01.00
12.01.01	12.01.01
12.01.02	12.01.02
56.00.03	56.00.03
56.00.04	56.00.04
56.00.05	56.00.05

- 5 Create input condition:** When the device is selected, click [Power] and click [Apply].
- [Power] means the operation state (On/Off).

Setting control logic

Name:

Period: 2017 8 7 - 2018 8 7 No limit

Day: Sun Mon Tue Wed Thu Fri Sat Daily

Time: 0 : 0 - 24 : 0

Factor edit: Single

Device: Select

11.00.00 Power

* Click 'Select' button : a pop-up window appears and you can select a device.

Apply

Compound factor	Factor	Comparison operator	Standard value	Duration (minute)
<input type="checkbox"/>	Select a factor	=	<input checked="" type="radio"/> None <input type="radio"/> Select a factor	<input checked="" type="radio"/> Cancel <input type="radio"/> Apply 1
<input type="checkbox"/> AND	Select a factor	=	<input checked="" type="radio"/> None <input type="radio"/> Select a factor	<input checked="" type="radio"/> Cancel <input type="radio"/> Apply 1
<input type="checkbox"/> AND	Select a factor	=	<input checked="" type="radio"/> None <input type="radio"/> Select a factor	<input checked="" type="radio"/> Cancel <input type="radio"/> Apply 1

- 6 Create input condition:** Select '=' as a comparison operator and select "Off" as a standard value.
- Meaning: Execute output control when 12.00.00 device is off.

Compound factor	Factor	Comparison operator	Standard value	Duration (minute)
<input type="checkbox"/>	12.00.00.Power	=	<input checked="" type="radio"/> Off <input type="radio"/> Select a factor	<input checked="" type="radio"/> Cancel <input type="radio"/> Apply 1
<input type="checkbox"/> AND	Select a factor	=	<input checked="" type="radio"/> None <input type="radio"/> Select a factor	<input checked="" type="radio"/> Cancel <input type="radio"/> Apply 1
<input type="checkbox"/> AND	Select a factor	=	<input checked="" type="radio"/> None <input type="radio"/> Select a factor	<input checked="" type="radio"/> Cancel <input type="radio"/> Apply 1

7 Create output: From the output window, select the device to apply the control when input condition is satisfied. Click [Apply] when selection is completed.

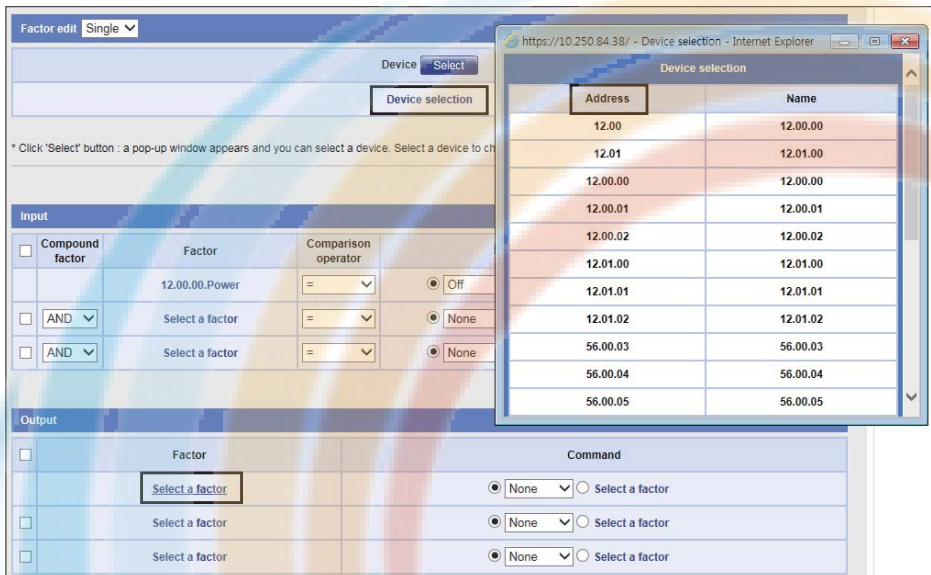

8 Create output: Select “Power” as a factor of the selected device and click [Apply].



9 Create output: From the output window, select the control to be executed when input condition is satisfied.
 • Turn off the ERV no. 0

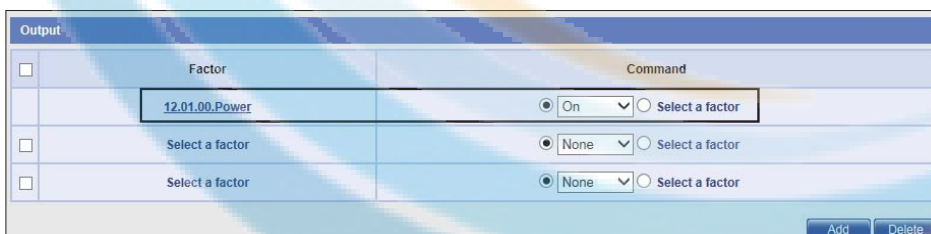

10 Click [Save] when the setting is completed.

11 To apply the new logic control, select the created logic and click [Apply].



Control example – Control logic

Ex) Control logic 1: Turn on 4 indoor units when outdoor temperature is 30°C or higher.
 Control logic 2: Turn off 4 indoor units when outdoor temperature is 26°C.

- Control logic 1

Name	PowerOn_Temp30
Period	2017 8 7 - 2018 8 7 <input type="checkbox"/> No limit
Day	<input type="checkbox"/> Sun <input type="checkbox"/> Mon <input type="checkbox"/> Tue <input type="checkbox"/> Wed <input type="checkbox"/> Thu <input type="checkbox"/> Fri <input type="checkbox"/> Sat <input checked="" type="checkbox"/> Daily
Time	0 : 0 - 24 : 0

Input				
Compound factor	Factor	Comparison operator	Standard value	Duration (minute)
	00,00,00,Outdoor temp.	=>	30 <input type="radio"/> Select a factor	<input type="radio"/> Cancel <input checked="" type="radio"/> Apply 5
<input type="checkbox"/> AND	Select a factor	=	None <input type="radio"/> Select a factor	<input checked="" type="radio"/> Cancel <input type="radio"/> Apply 1
<input type="checkbox"/> AND	Select a factor	=	None <input type="radio"/> Select a factor	<input checked="" type="radio"/> Cancel <input type="radio"/> Apply 1
Output				
<input checked="" type="checkbox"/>	Factor	Command		
	00,00,00,Power	<input checked="" type="radio"/> On <input type="radio"/> Select a factor		
<input checked="" type="checkbox"/>	00,00,01,Power	<input checked="" type="radio"/> On <input type="radio"/> Select a factor		
<input checked="" type="checkbox"/>	00,00,02,Power	<input checked="" type="radio"/> On <input type="radio"/> Select a factor		
<input checked="" type="checkbox"/>	00,00,03,Power	<input checked="" type="radio"/> On <input type="radio"/> Select a factor		

1. Input: When outdoor temperature is 30°C (86°F) or higher.
2. When condition 1 lasted for 5 minute.
3. Output: Turn on 4 indoor units.

• Control logic 2

Name	PowerOff_Temp26							
Period	2017	8	7	-	2018	8	7	<input type="checkbox"/> No limit
Day	<input type="checkbox"/> Sun	<input type="checkbox"/> Mon	<input type="checkbox"/> Tue	<input type="checkbox"/> Wed	<input type="checkbox"/> Thu	<input type="checkbox"/> Fri	<input type="checkbox"/> Sat	<input checked="" type="checkbox"/> Daily
Time	0	:	0	-	24	:	0	

Input				
Compound factor	Factor	Comparison operator	Standard value	Duration (minute)
<input type="checkbox"/>	00,00,00,Outdoor temp.	=<	26 <input type="radio"/> Select a factor	<input checked="" type="radio"/> Cancel <input type="radio"/> Apply 1
<input type="checkbox"/> AND	Select a factor	=	None <input type="radio"/> Select a factor	<input checked="" type="radio"/> Cancel <input type="radio"/> Apply 1
<input type="checkbox"/> AND	Select a factor	=	None <input type="radio"/> Select a factor	<input checked="" type="radio"/> Cancel <input type="radio"/> Apply 1

Output	
Factor	Command
<input checked="" type="checkbox"/> 00,00,00,Power	<input checked="" type="radio"/> Off <input type="radio"/> Select a factor
<input checked="" type="checkbox"/> 00,00,01,Power	<input checked="" type="radio"/> Off <input type="radio"/> Select a factor
<input checked="" type="checkbox"/> 00,00,02,Power	<input checked="" type="radio"/> Off <input type="radio"/> Select a factor
<input checked="" type="checkbox"/> 00,00,03,Power	<input checked="" type="radio"/> Off <input type="radio"/> Select a factor

1. Input: When outdoor temperature is 26°C(78°F) or lower.

2. Output: Turn off 4 indoor units.

• Register control logic

Setting control logic							
<input checked="" type="checkbox"/>	No.	Name	Period	Days	Time	Apply	Run
<input checked="" type="checkbox"/>	1	PowerOn_Temp30	2011-01-19 ~ 2012-01-19	Daily	00:00 ~ 24:00	No	No
<input checked="" type="checkbox"/>	2	PowerOff_Temp26	2011-01-19 ~ 2012-01-19	Daily	00:00 ~ 24:00	No	No

01 Click

02 Click



• Control logic applied

Setting control logic							
<input type="checkbox"/>	No.	Name	Period	Days	Time	Apply	Run
<input type="checkbox"/>	1	PowerOn_Temp30	2011-01-19 ~ 2012-01-19	Daily	00:00 ~ 24:00	Yes	No
<input type="checkbox"/>	2	PowerOff_Temp26	2011-01-19 ~ 2012-01-19	Daily	00:00 ~ 24:00	Yes	No

Application completed

Power distribution

Where does power consumption occurs?

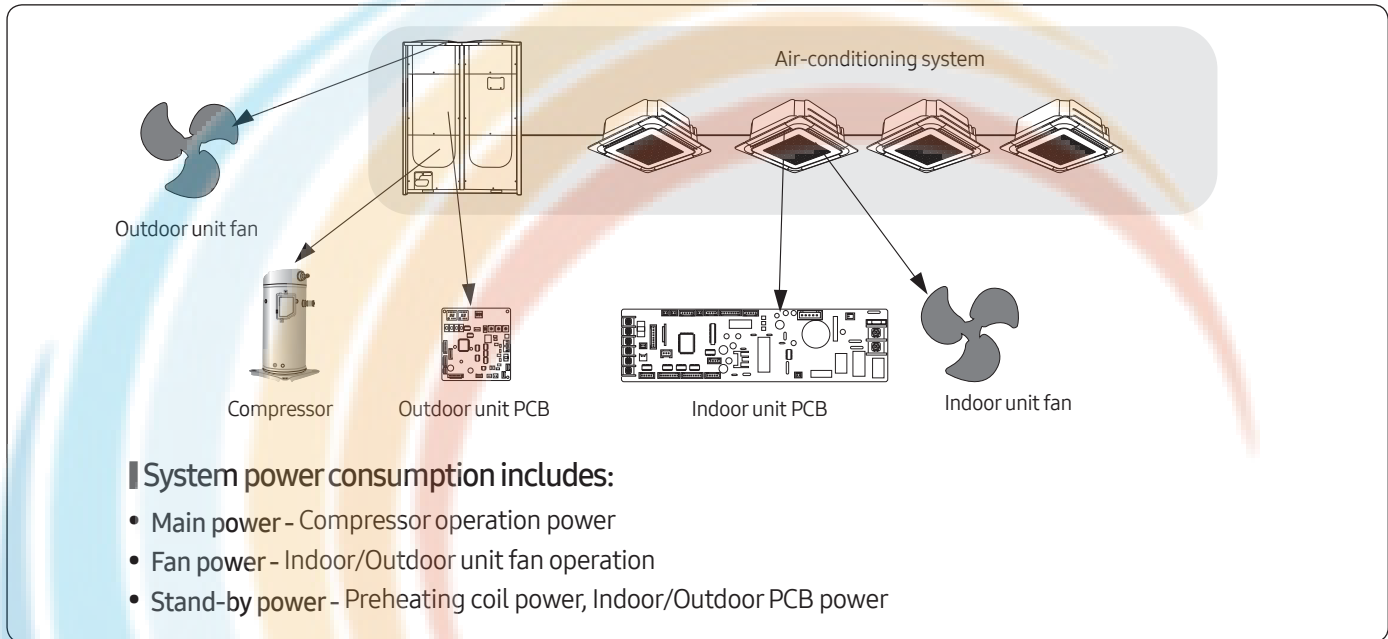

DMS2.5 power distribution theory

All the system information of power and indoor/outdoor operation is always monitored by the DMS2.5 for power distribution calculation.

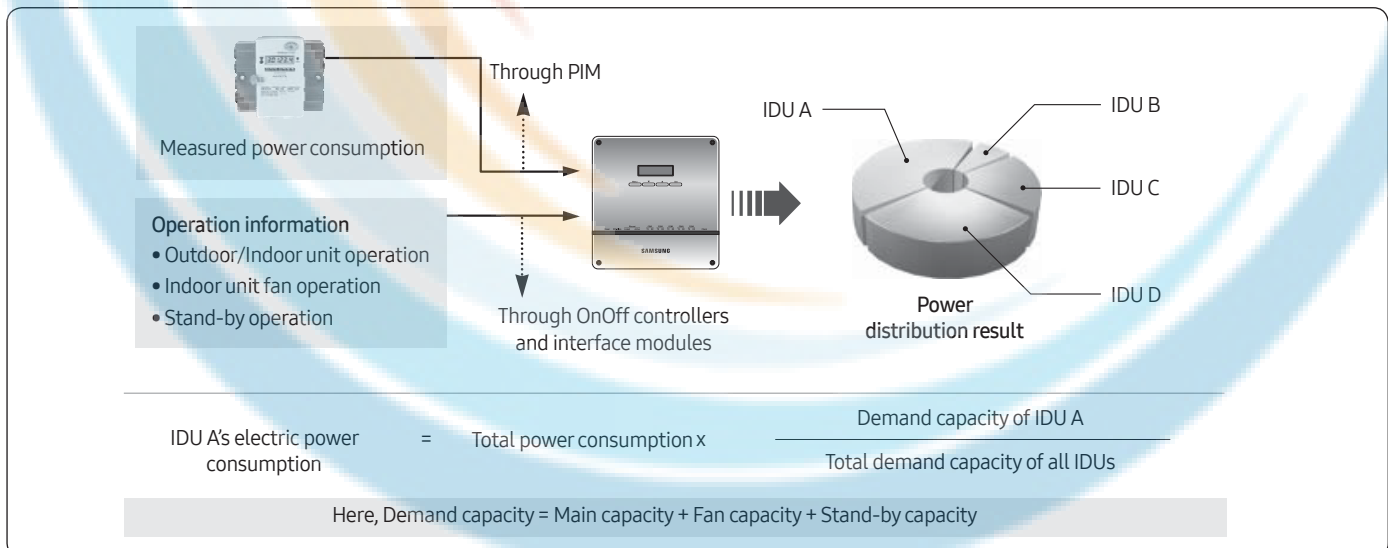

Note

- Demand capacity means the value that parameters of different units like required power and refrigerant amount are transformed into as a common number to make easy algebraic calculation.
- Power distribution is not supported to ERV, DVM CHILLER, FCU KIT.
- You can check DVM CHILLER's power consumption in the meter history menu. (PIM and watt-hour meter must be connected)

Main capacity

This is determined dynamically with the combination of various refrigerating parameters such as difference between room and set temperature or evaporator input/output temperature.

These parameters, as a result, determine the refrigerant amount flowing into the indoor unit by controlling EEV steps.

Fan capacity

This is constant value for indoor unit models. It differs depending on indoor units of different capacity.

When the indoor unit starts Cooling, Heating, Auto and Fan modes, fan capacity values of the indoor units are always monitored by the DMS2.5. DMS2.5 gathers capacity of zero value when they stop operating.

Stand-by capacity

Stand-by capacity is constant for all indoor units regardless of their operations. Since stand-by power is consumed all the time by PCBs and preheating coils in the outdoor unit, whose value is monitored with the same fraction which is relatively small compared to main capacity or fan capacity.

What if the room temperature begins to reach the set temperature?

If the room temperature begins to reach the set temperature, the indoor unit does not have to extract the full refrigerant amount to keep the set condition. Capacity from the indoor unit goes down to indicate the outdoor unit that it does not need refrigerant at the full capacity state.

When the room temperature has reached the set temperature, there is no need to pump the refrigerant into the indoor unit. Indoor unit goes into the thermally OFF state and sends capacity of zero value to the outdoor unit and the DMS2.5, which results in fan or stand-by power distribution only.

Capacity accumulation and power distribution

DMS2.5 gathers power consumption and capacity values during one-day.

At midnight, 1-day power consumption is distributed to the indoor units using the gathered information.

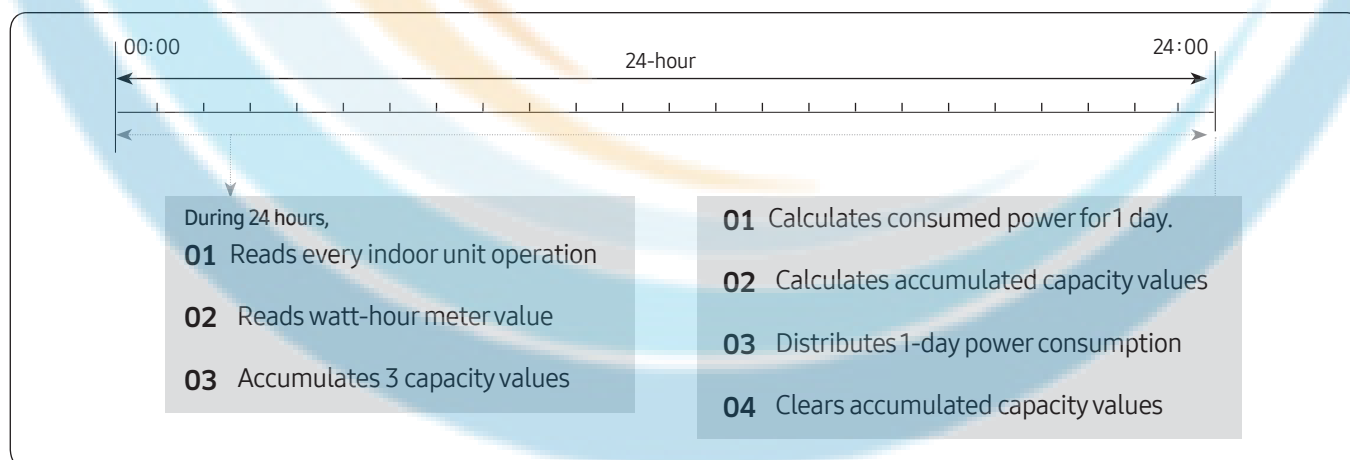

Not equal stand-by power distribution (In case all the indoor units are stopped)

Since there always exists error in each power consumption amount, distributed stand-by power may not be equal for different air-conditioning system. But the difference is so small that it is negligible.

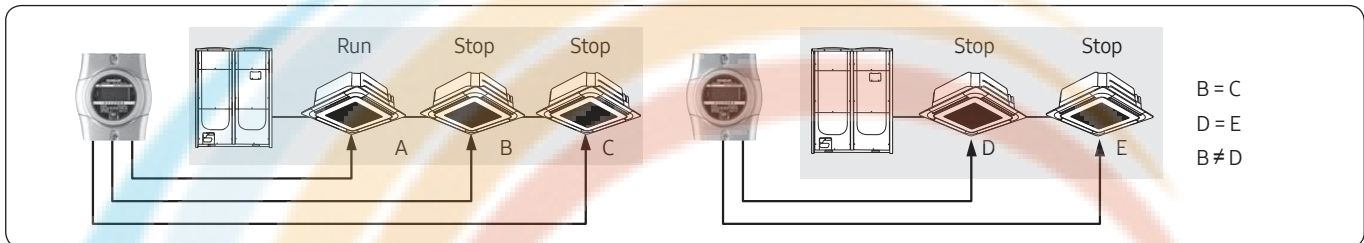

• Power distribution equation

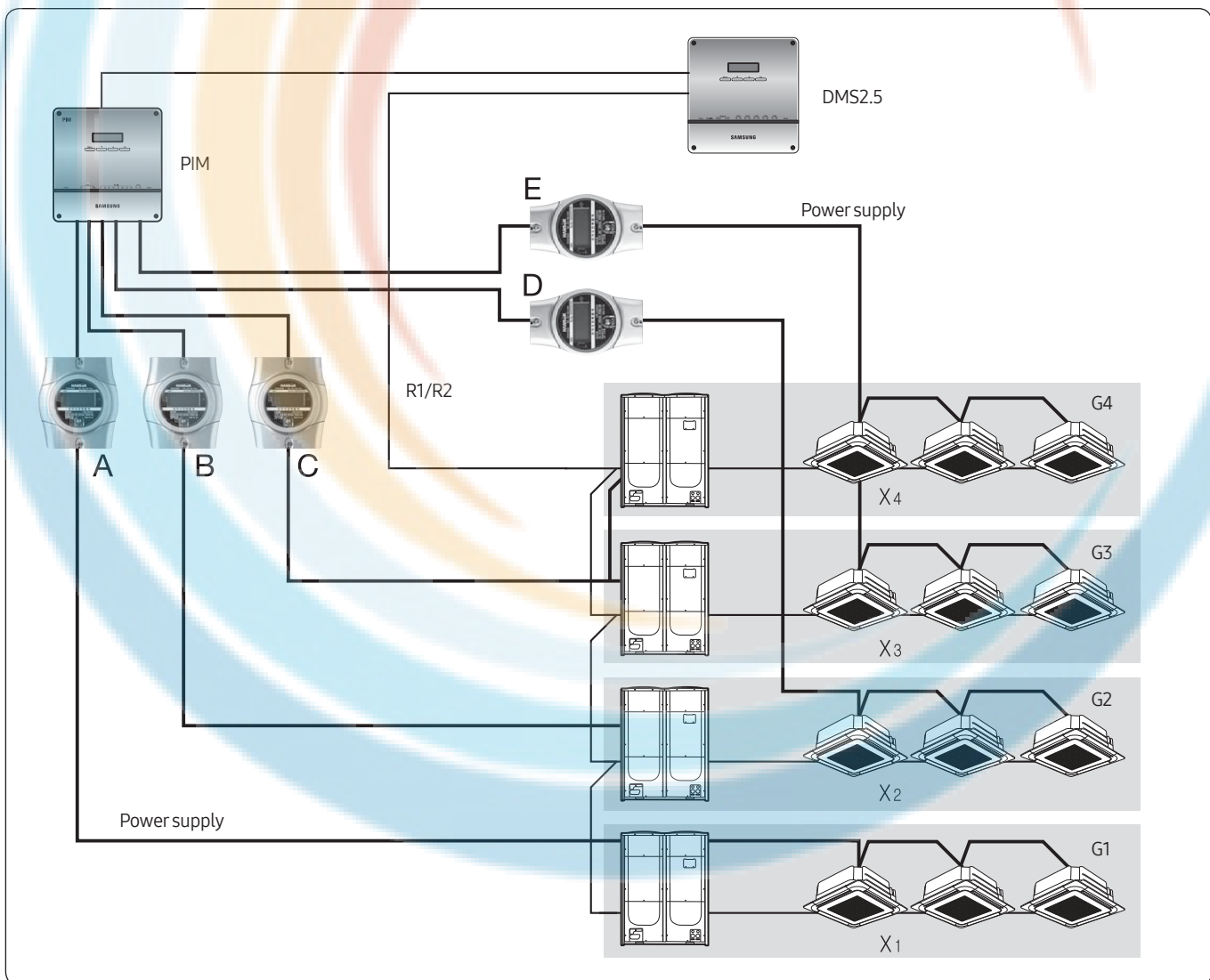

- When configuring the DMS2.5 and the whole system, mapping of watt-hour meters for indoor/outdoor units must be precisely assigned for correct power distribution.

$$\begin{aligned} \text{Indoor unit power X in G1} &= \text{Watt-hour A} \times \frac{\text{Main + Fan + Stand-by capacity of indoor unit X}}{\text{Total capacity of G1}} \\ \text{Indoor unit power X in G2} &= \text{Watt-hour B} \times \frac{\text{Main + Fan + Stand-by capacity of indoor unit X}}{\text{Total capacity of G2}} \\ &+ \text{Watt-hour D} \times \frac{\text{Main + Fan + Stand-by capacity of indoor unit X}}{\text{Total capacity of G2}} \\ \text{Indoor unit power X in G3+G4} &= \text{Watt-hour C} \times \frac{\text{Main + Fan + Stand-by capacity of indoor unit X}}{\text{Total capacity of G3 + G4}} \\ &+ \text{Watt-hour E} \times \frac{\text{Main + Fan + Stand-by capacity of indoor unit X}}{\text{Total capacity of G3+G4}} \end{aligned}$$

- Example**
 Suppose capacity values accumulated at 24:00 during one whole day is as follows.

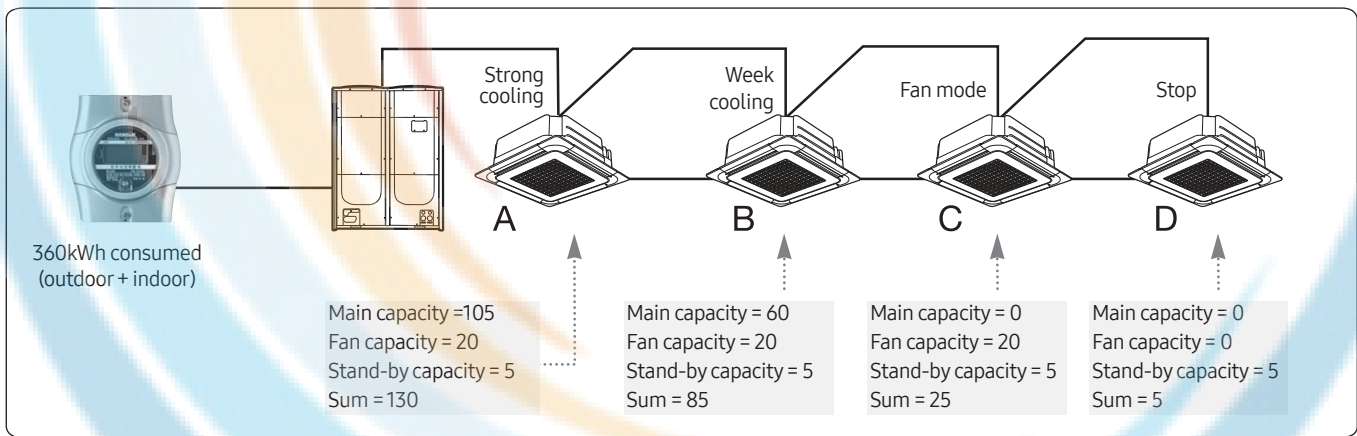

$$\begin{aligned} \text{Pd of Indoor unit A} &= \frac{\text{Indoor unit capacity}}{\text{Total capacity}} \times \text{Total kWh} = \frac{130 \times 360}{130 + 85 + 25 + 5} = 192.020 \text{ kWh} \\ \text{Pd of Indoor unit B} &= \frac{85 \times 360}{130 + 85 + 25 + 5} = 124.900 \text{ kWh} \\ \text{Pd of Indoor unit C} &= \frac{25 \times 360}{130 + 85 + 25 + 5} = 36.735 \text{ kWh} \\ \text{Pd of Indoor unit D} &= \frac{5 \times 360}{130 + 85 + 25 + 5} = 7.347 \text{ kWh} \end{aligned}$$

Installation example (Allowed)

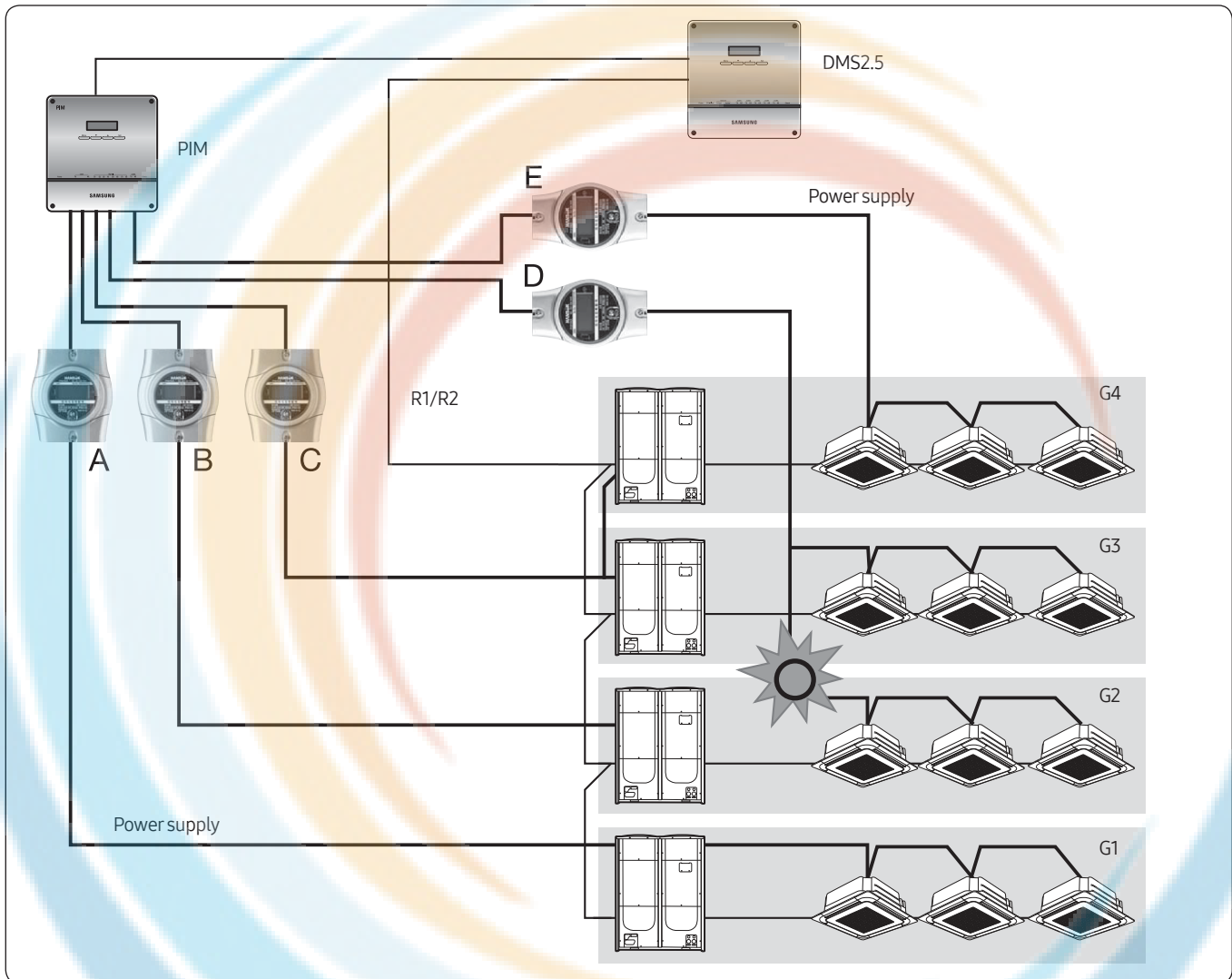

Mapping watt-hour meters to indoor/outdoor units

- Watt-hour meter A is mapped to all indoor/outdoor units in G1.
- Watt-hour meter B is mapped to the outdoor unit in G2.
- Watt-hour meter C is mapped to the outdoor units in G3 and G4.
- Watt-hour meter D is mapped to the indoor units in G2 + G3.
- Watt-hour meter E is mapped to the indoor units in G4.
- Installation above is allowed with proper mapping configuration.

Note

- Watt-hour meter can be shared to the multiple indoor/outdoor systems.

Installation example (Not allowed)

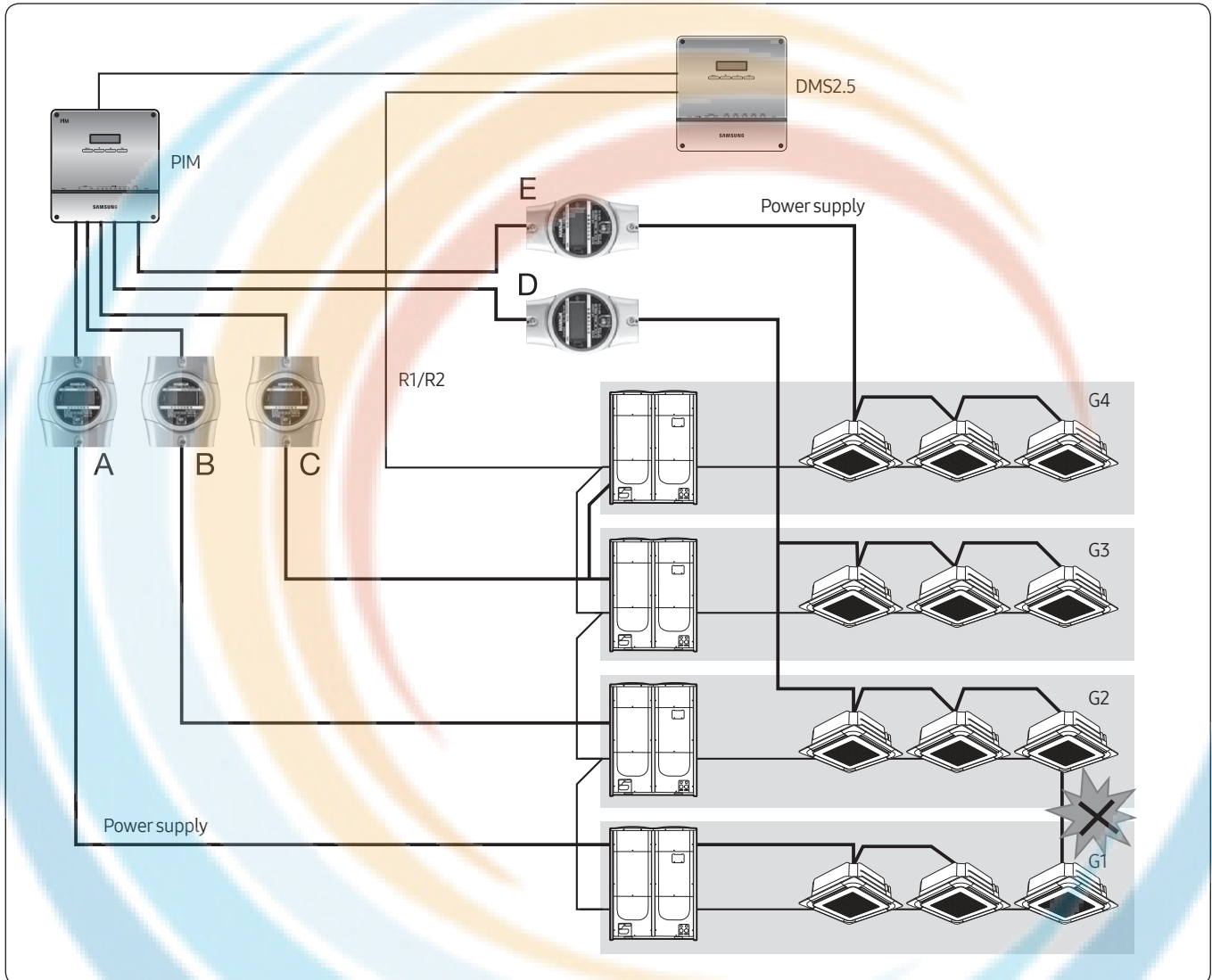

All indoor units in one outdoor unit must have the same power source.

- Installation above cannot be available for the reason that one indoor unit in G1 has different power source from the other indoor units. In this case, fractional power of D consumed by the separate-powered indoor unit in G1 is distributed to the indoor units in G2 and G3.

Setting the inspection section

If you want to check the distribution result by time period, set the time section.
 You must use S-NET3 to check the distribution result by time period.

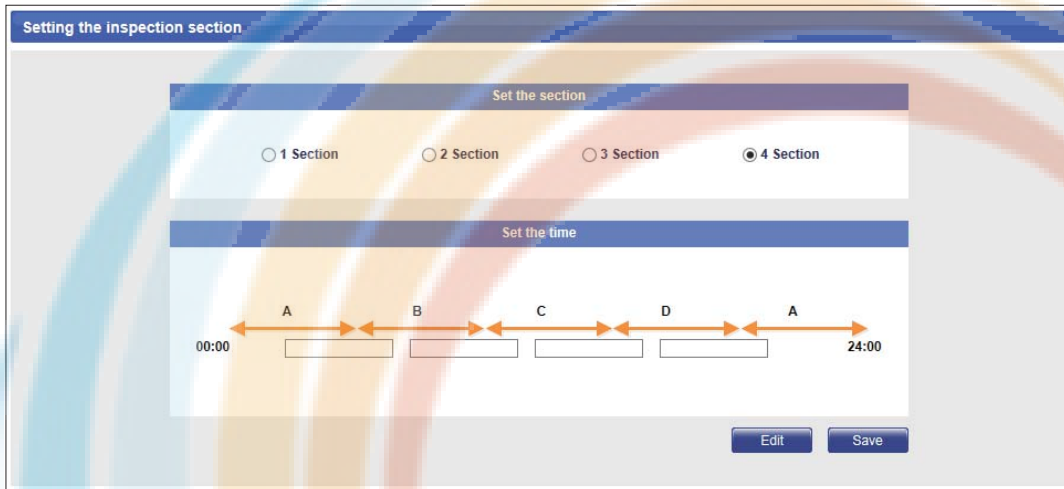

Setting the power distribution environment

This is important task for checking precise energy consumption of the outdoor/indoor unit. Each watt-hour meter connected to outdoor unit must be checked for which channel of the PIM interface module it is connected. Then PIM channel must be set according to the outdoor unit.

Indoor units must be checked which watt-hour meter it is connected to and then PIM channel of the corresponding watt-hour meter must be set according to indoor unit PIM channel as shown below.

Channel setting by indoor unit								
Indoor unit address	Indoor unit name	Outdoor unit SIM / PIM channel				Indoor unit SIM / PIM channel	Outdoor unit virtual channel	Indoor unit virtual channel
		Channel1	Channel2	Channel3	Channel4			
13.00.00	13.00.00	16.1				16.3		
13.00.01	13.00.01	16.1				16.3		
13.00.02	13.00.02	16.1				16.3		
13.01.00	13.01.00	16.2				16.4		
13.01.01	13.01.01	16.2				16.4		
13.01.02	13.01.02	16.2				16.4		

- Example of watt hour meter installation 1
 Installing watt-hour meter to outdoor/indoor unit

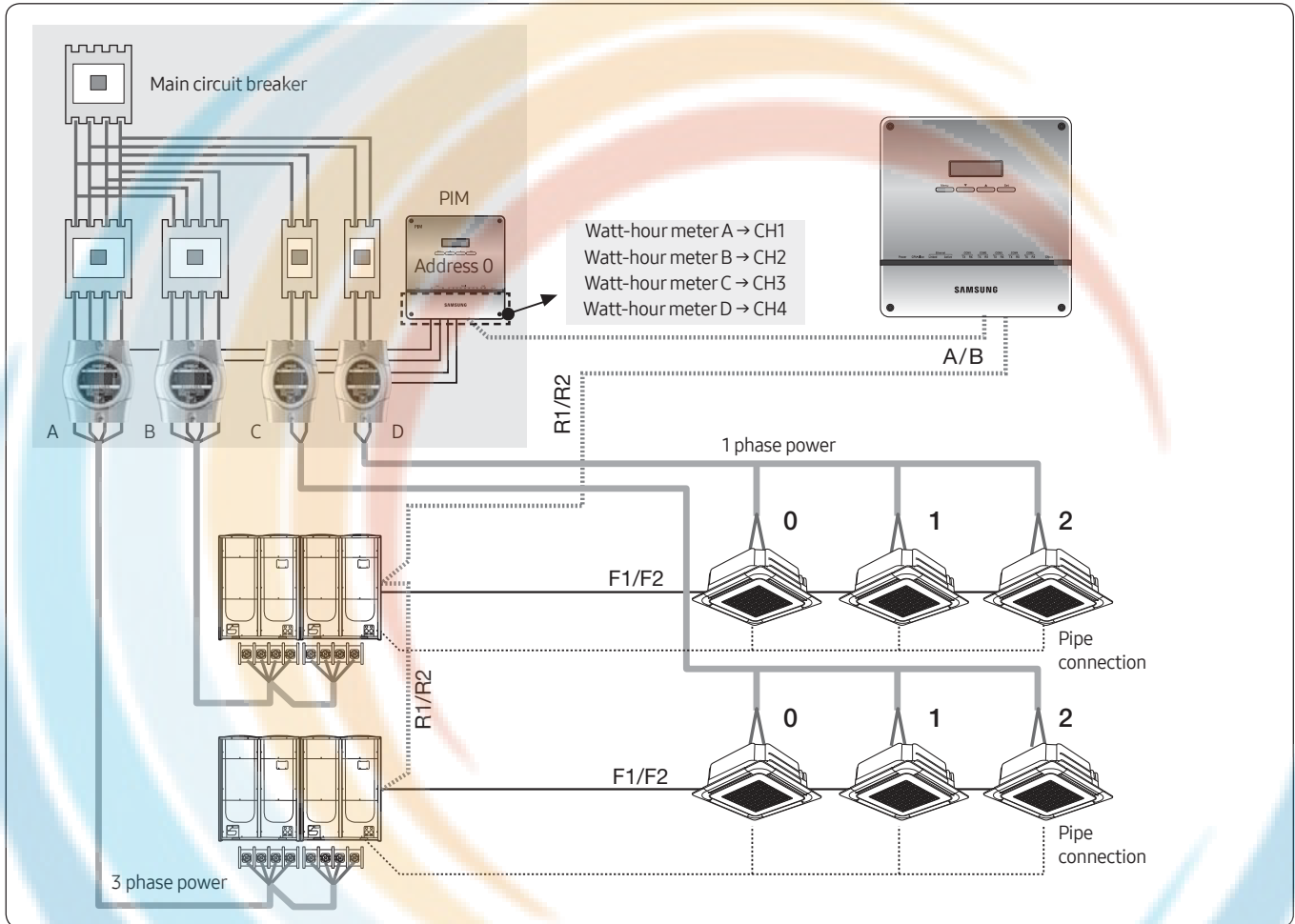

Channel setting by indoor unit								
Indoor unit address	Indoor unit name	Outdoor unit SIM / PIM channel				Indoor unit SIM / PIM channel	Outdoor unit virtual channel	Indoor unit virtual channel
		Channel1	Channel2	Channel3	Channel4			
13.00.00	13.00.00	16.1				16.3		
13.00.01	13.00.01	16.1				16.3		
13.00.02	13.00.02	16.1				16.3		
13.01.00	13.01.00	16.2				16.4		
13.01.01	13.01.01	16.2				16.4		
13.01.02	13.01.02	16.2				16.4		

⚠ Caution

- Connect appropriate watt-hour meter to outdoor/indoor unit.

- Example of watt hour meter installation 2
 Installing 1 watt-hour meter to all indoor units

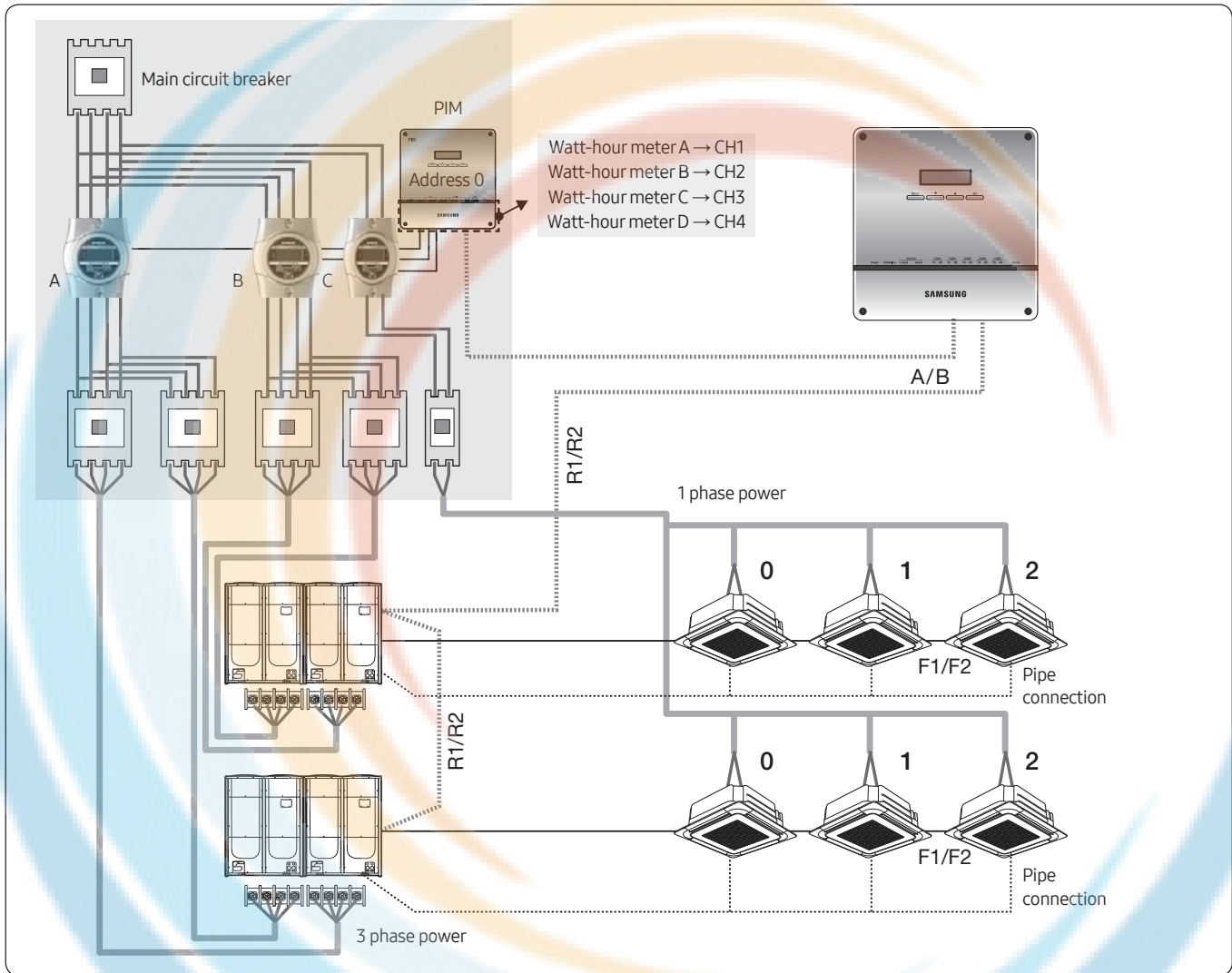

Channel setting by indoor unit								
Indoor unit address	Indoor unit name	Outdoor unit SIM / PIM channel				Indoor unit SIM / PIM channel	Outdoor unit virtual channel	Indoor unit virtual channel
		Channel1	Channel2	Channel3	Channel4			
13.00.00	13.00.00	16.1				16.3		
13.00.01	13.00.01	16.1				16.3		
13.00.02	13.00.02	16.1				16.3		
13.01.00	13.01.00	16.2				16.3		
13.01.01	13.01.01	16.2				16.3		
13.01.02	13.01.02	16.2				16.3		

Since all indoor units are connected to 1 watt-hour meter, PIM channel address of all indoor units is same.

- Example of watt hour meter installation 3
 Using CT watt-hour meter to and outdoor unit

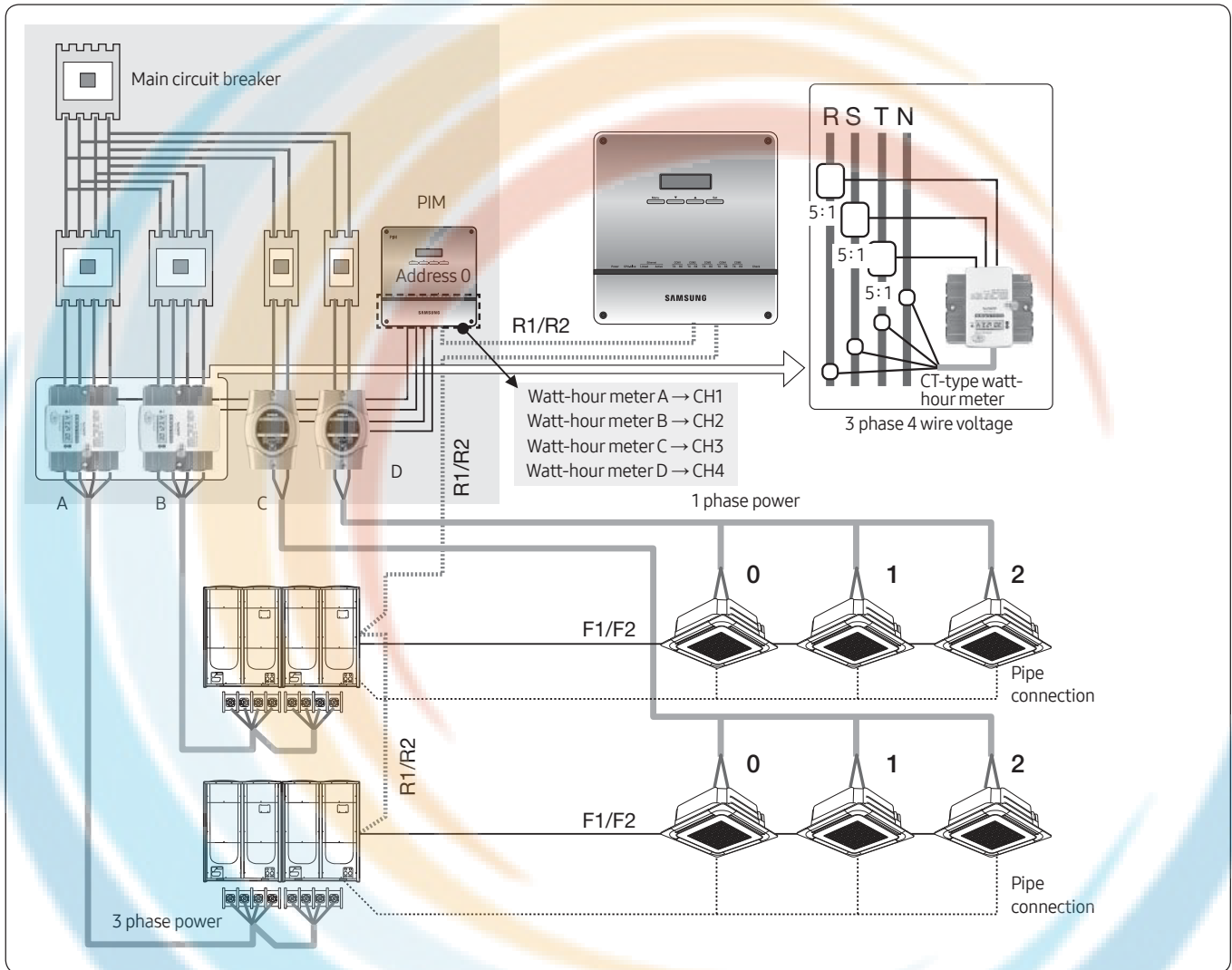

Setting and checking watt-hour meter			Kilowatthour history
SIM / PIM Channel	Name	CT proportion	Watt-hour meter value (kWh)
16.1	16.1	5	100.0
16.2	16.2	5	100.0
16.3	16.3	1	100.0
16.4	16.4	1	100.0
16.5	16.5	1	100.0
16.6	16.6	1	100.0
16.7	16.7	1	100.0
16.8	16.8	1	100.0

[Setting and checking watt-hour meter]
 From the menu, CT proportion of the CT watt-hour meter must be entered.

Note

- After entering CT proportion of the CT watt-hour meter, watt-hour meter must be set to correct outdoor/ indoor units from the [Channel setting by indoor unit] window.

- Checking the watt-hour meter connection
 Kilowatt-hour history of the watt-hour meter, connected to each PIM interface module, can be checked.
 Maximum 365 days worth of Kilowatt-hour history can be checked.

Setting and checking watt-hour meter Kilowatt-hour history

SIM / PIM Channel	Name	CT proportion	Watt-hour meter value (kWh)
16.1	16.1	5	100.0
16.2	16.2	5	100.0
16.3	16.3	1	100.0
16.4	16.4	1	100.0
16.5	16.5	1	100.0
16.6	16.6	1	100.0
16.7	16.7	1	100.0
16.8	16.8	1	100.0

SIM / PIM Address **16** Kilowatt-hour setting & inquiry

2011 ~ 2011 1 15 ~ 2011 1 18 Check

Date	16.1	16.2	16.3	16.4	16.5	16.6	16.7	16.8
2011-01-15	0.0	0.0	0.0	0.0	0.0	0.0	0.0	0.0
2011-01-16	0.0	0.0	0.0	0.0	0.0	0.0	0.0	0.0
2011-01-17	0.0	0.0	0.0	0.0	0.0	0.0	0.0	0.0
2011-01-18	1940.9	240.4	3199.7	299.9	0.0	0.0	0.0	0.0

- Setting virtual watt-hour meter
 When watt-hour meter or PIM interface module is not installed to a watt-hour meter channel, virtual channel can be used to manually distribute the power distribution

Setting and checking virtual channel

Virtual Channel	Name
24.1	24.1
24.2	24.2
24.3	24.3
24.4	24.4
24.5	24.5
31.11	31.11
31.12	31.12
31.13	31.13
31.14	31.14
31.15	31.15
31.16	31.16

- Maximum 128 virtual channel can be used.
- Address of the virtual channel will be displayed as following. (24~31).(1~16)

Channel setting by indoor unit

Indoor unit address	Indoor unit name	Outdoor unit SIM / PIM channel				Indoor unit SIM / PIM channel	Outdoor unit virtual channel	Indoor unit virtual channel
		Channel1	Channel2	Channel3	Channel4			
13.00.00	13.00.00	<input type="text"/>	<input type="text"/>	<input type="text"/>	<input type="text"/>	<input type="text"/>	24.1	24.3
13.00.01	13.00.01	<input type="text"/>	<input type="text"/>	<input type="text"/>	<input type="text"/>	<input type="text"/>	24.1	24.3
13.00.02	13.00.02	<input type="text"/>	<input type="text"/>	<input type="text"/>	<input type="text"/>	<input type="text"/>	24.1	24.3
13.01.00	13.01.00	<input type="text"/>	<input type="text"/>	<input type="text"/>	<input type="text"/>	<input type="text"/>	24.2	24.4
13.01.01	13.01.01	<input type="text"/>	<input type="text"/>	<input type="text"/>	<input type="text"/>	<input type="text"/>	24.2	24.4
13.01.02	13.01.02	<input type="text"/>	<input type="text"/>	<input type="text"/>	<input type="text"/>	<input type="text"/>	24.2	24.4

Note

- When PIM interface module is not installed, PIM channel of the outdoor/indoor unit will be inactive.

- Caution
 Power distribution function is only supported to air conditioners and AHU. ERV is not supported.

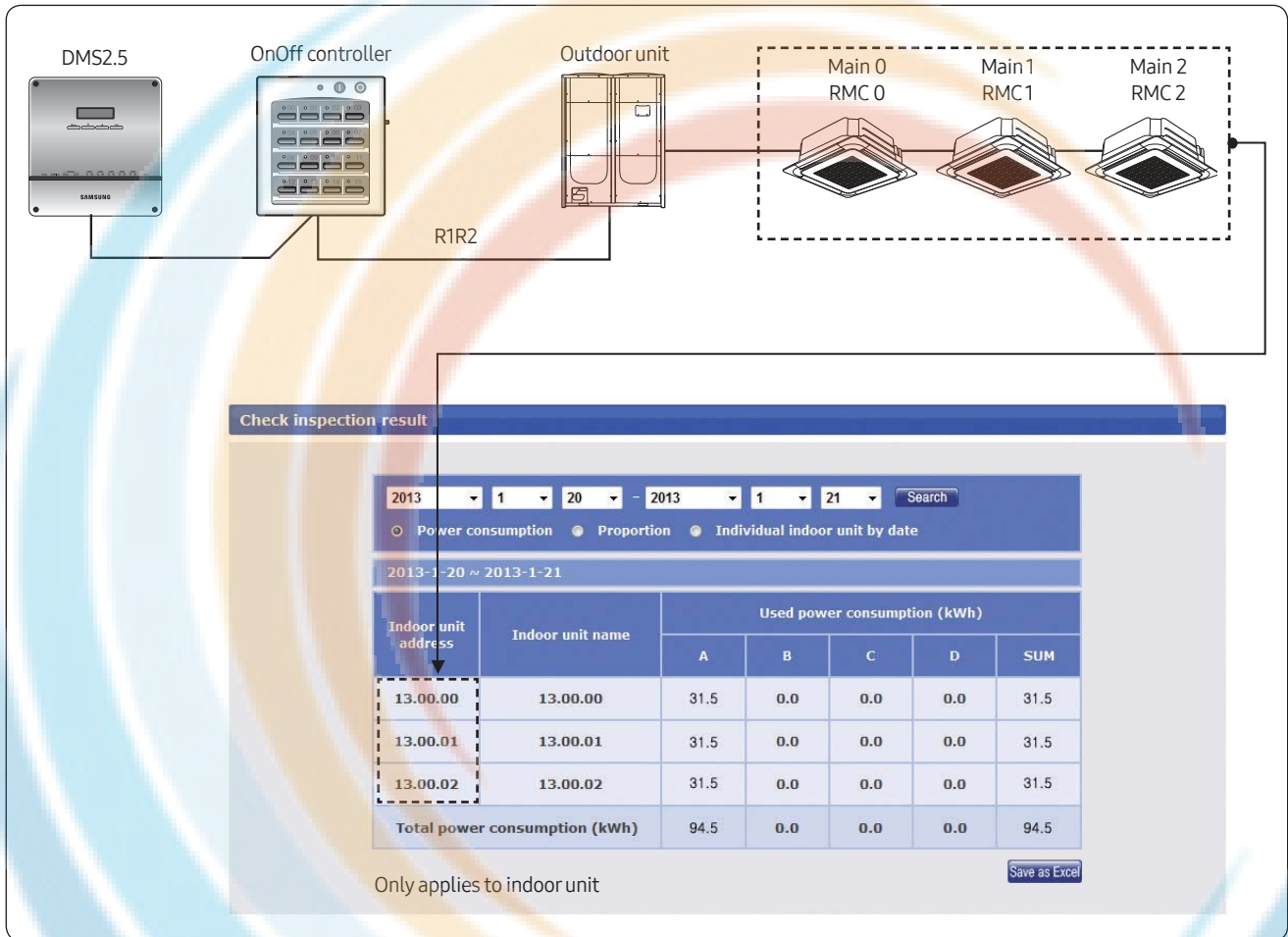

■ User authorization management

Menu	Admin	Manager	Regular user
Control and Monitoring	<input checked="" type="checkbox"/>	<input checked="" type="checkbox"/>	<input checked="" type="checkbox"/>
Zone management	<input checked="" type="checkbox"/>	<input checked="" type="checkbox"/>	<input type="checkbox"/>
Schedule	<input checked="" type="checkbox"/>	<input checked="" type="checkbox"/>	<input type="checkbox"/>
EHP Power Consumption Inspection	<input checked="" type="checkbox"/>	<input checked="" type="checkbox"/>	<input type="checkbox"/>
Control logic management	<input checked="" type="checkbox"/>	<input checked="" type="checkbox"/>	<input type="checkbox"/>
System Settings	<input checked="" type="checkbox"/>	<input checked="" type="checkbox"/>	<input type="checkbox"/>

Save Initialize

- Admin (Administrator): Can access all menus, accessible menu cannot be changed
- Manager: Default setting – Can access all menus, accessible menu can be changed.
- Regular user: Default setting – Can access [Control and monitoring] menu only.

■ Editing user authorization

Menu	Admin	Manager	Regular user
Control and Monitoring	<input checked="" type="checkbox"/>	<input checked="" type="checkbox"/>	<input checked="" type="checkbox"/>
Zone management	<input checked="" type="checkbox"/>	<input type="checkbox"/>	<input type="checkbox"/>
Schedule	<input checked="" type="checkbox"/>	<input type="checkbox"/>	<input type="checkbox"/>
EHP Power Consumption Inspection	<input checked="" type="checkbox"/>	<input type="checkbox"/>	<input type="checkbox"/>
Control logic management	<input checked="" type="checkbox"/>	<input checked="" type="checkbox"/>	<input type="checkbox"/>
System Settings	<input checked="" type="checkbox"/>	<input checked="" type="checkbox"/>	<input type="checkbox"/>

Save Initialize

- Accessible menu authorization of manager is editable.
 Select/deselect the checkbox of the function and save the setting to change the authorization.

User management



The screenshot shows a web interface titled "User management". It contains a table with the following data:

ID	Password	Name	Description	Registration date	Authorization
admin	1234	admin	admin	2009.1.1	Admin
guest	guest	guest	guest	2009.1.1	Regular user

Below the table is a button labeled "Add user".

- You can add or delete the user who access DMS2.5 through web.

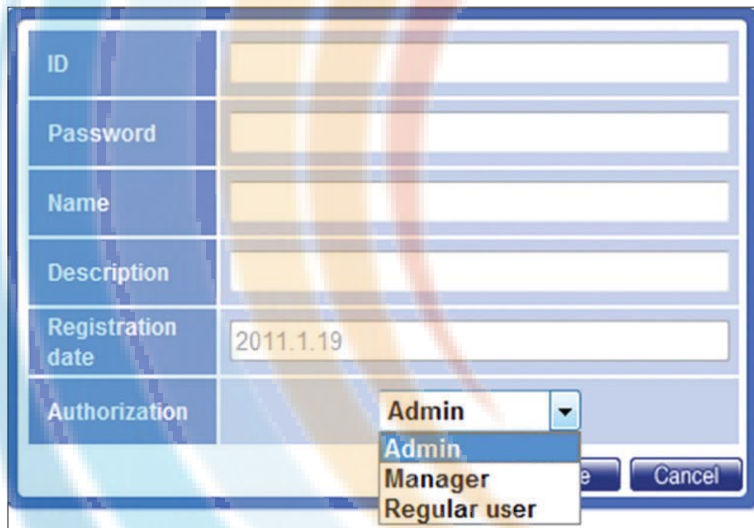

The screenshot shows a form for adding a new user. The fields are:

- ID:
- Password:
- Name:
- Description:
- Registration date:
- Authorization: (dropdown menu)

The dropdown menu for Authorization is open, showing the following options: Admin, Manager, and Regular user. There are "Save" and "Cancel" buttons at the bottom right of the form.

- Authorization of the added user can be set from [Admin], [Manager], [Regular user].

Zone management

- Zone edit: User can arrange the indoor units for convenient management.
- Setting the user authorization: Can restrict accessible indoor units depending on the user ID.

Zone edit

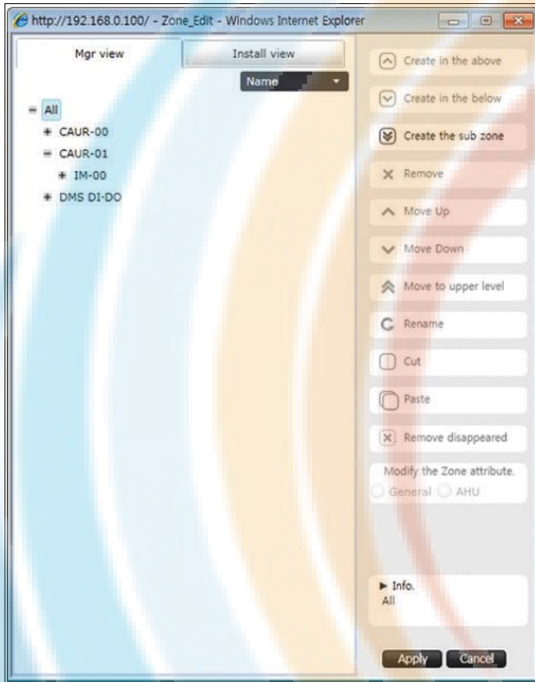

Initial setting

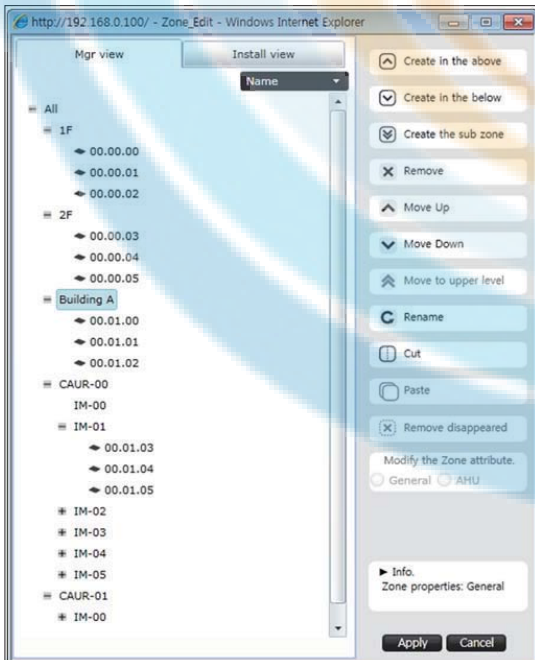

Zone edit :

- Add, delete zone
- Change name
- Move indoor unit

Setting the user authorization

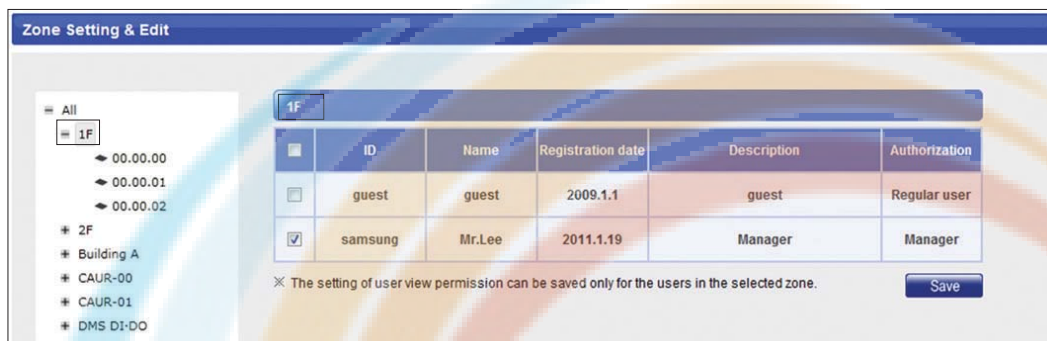

- Authorization to control and monitor a zone of indoor units can be assigned according to User ID

- 1 Select the zone and select a user ID who can access the zone.
 - Access authorization can be set by zone.
- 2 After setting, click [Save] to complete the authorization setting.

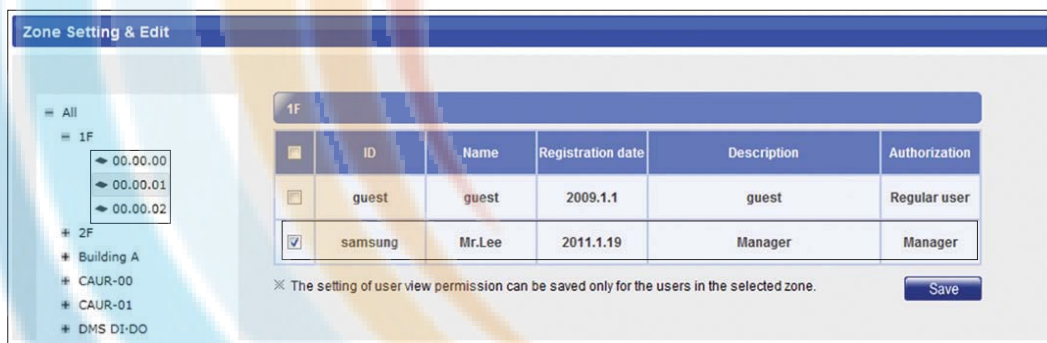

- User access authorization applies to all indoor units of the zone in same manager.

Control for unoccupied room

- It is the function to keep the room temperature when user goes out for a while.
- User can set the detail operation of [Unoccupied room control] using DMS2.5 or S-NET pro2.

Note

- Applicable indoor unit and controller
 Indoor unit: New communication applied indoor unit. (Software version check is required) FCU
 KIT: MIM-F00N

Diagram

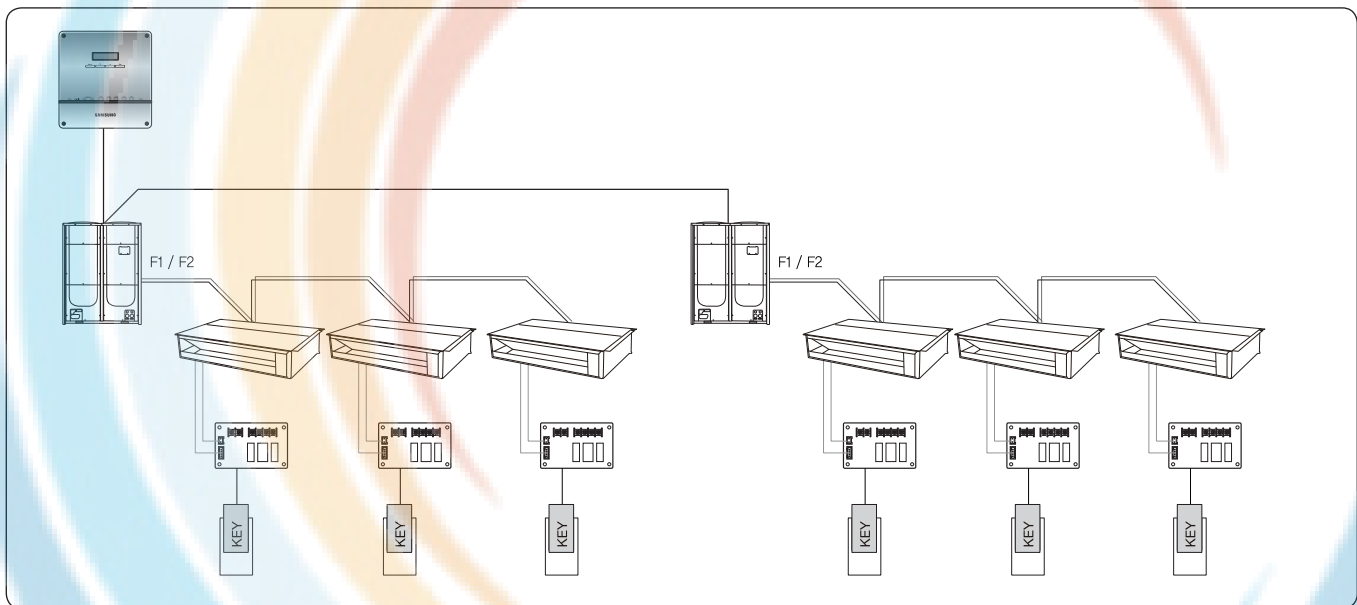

Requirement

- To use this function, external contact interface module (MIM-B14) should be installed to indoor unit.
- Installation option code of indoor unit [SEG14] should be set

[Installation option code SEG14]

SEG14	Contact	Operation of [Unoccupied room mode]		
		Indoor unit	Use of R/C	Use of upper controller
1	Close	ON	O	O
	Open	Operates as [Unoccupied room mode]	O	O
2	Close	Stay OFF	O	O
	Open	Operates as [Unoccupied room mode]	X	X
3	Close	Operates as last status before [Contact = Open]	O	O
	Open	Operates as [Unoccupied room mode]	X	X

Setting

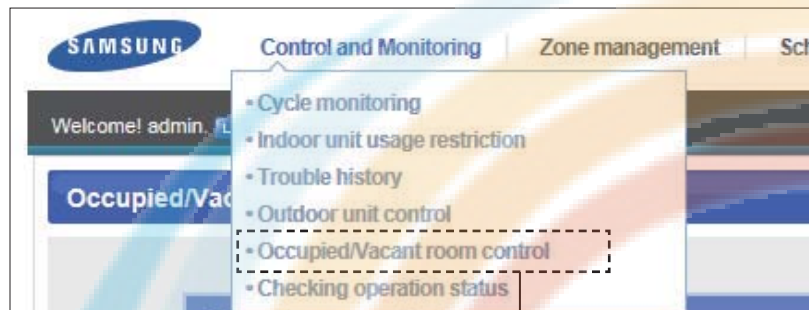

The screenshot shows the 'Vacant room control' configuration page. The page has a tab for 'Occupied room' and a 'Vacant room control' tab. Below the tabs is a table with the following columns: Address, Name, Mode, Desired temp., Fan speed, and Apply. The table contains five rows of data, each representing an indoor unit. The 'Apply' column has radio buttons for 'Disable' and 'Enable'.

Address	Name	Mode	Desired temp.	Fan speed	Apply
All	All	▼	°C	▼	
12.00.00	12.00.00	Auto ▼	0.0 °C	Auto ▼	<input checked="" type="radio"/> Disable <input type="radio"/> Enable
12.00.01	12.00.01	Auto ▼	0.0 °C	Auto ▼	<input checked="" type="radio"/> Disable <input type="radio"/> Enable
12.00.02	12.00.02	Auto ▼	0.0 °C	Auto ▼	<input checked="" type="radio"/> Disable <input type="radio"/> Enable
12.01.00	12.01.00	Auto ▼	0.0 °C	Auto ▼	<input checked="" type="radio"/> Disable <input type="radio"/> Enable

- Control and Monitoring] > [Occupied/Vacant room control] menu:
You can see indoor units which can support [Vacant room control]
- Set [Apply]
 - Enable: Indoor unit operates as [Vacant room control] when contact status is open.
 - Disable: Indoor unit stops when contact status is open.
- Set detail operation
 - Mode, Desired temperature, fan speed
 - Setting value is saved in indoor unit memory. (The setting value will be maintained in case of power failure or DMS2.5 removal)

Pre-heating/Pre-cooling control for occupied room

- This is a function to detect a user entrance (via an external contact) and to automatically perform the pre-heating, pre-cooling.
- It applies when the contact state of MIM-B14 which is connected to the indoor unit is Close.
- Detailed pre-operation settings is set by DMS2.5 or S-NET Pro2.
- Occupied and unoccupied control can be used at the same time.

Note

- Applicable indoor unit and controller
Indoor unit: New communication indoor unit
Controller: DMS 2.5, S-NET pro2

Diagram

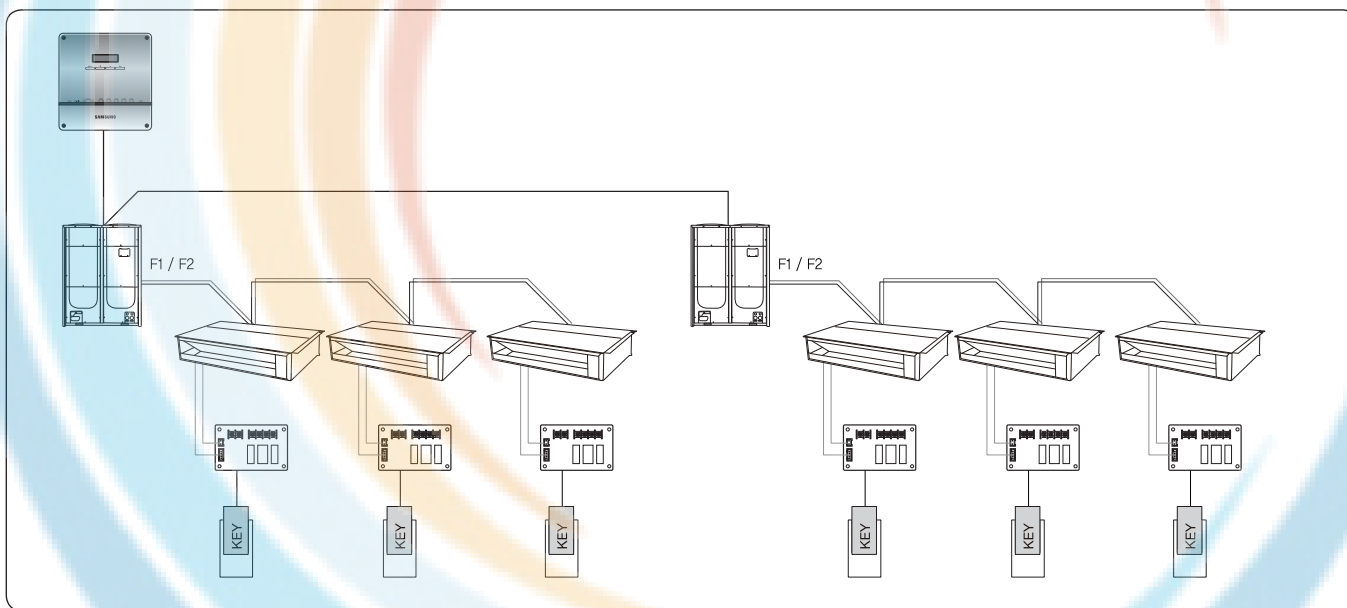

Requirement

Case	Indoor unit	DMS2.5/ S-NET PRO2	Description	
	External contact control (Installation option SEG14)	Vacant room control	In open contact (=Vacant room)	Use of R/C in open contact
1	On/Off Control (1)	Enable	On as [setting of Vacant room control]	0
2		Disable	Off	0
3	Off only Control (2)	Enable	On as [setting of Vacant room control]	X
4		Disable	Off	X
5	Window Control (3)	Enable	On as [setting of Vacant room control]	X
6		Disable	Off	X

Case	Indoor unit	DMS2.5/ S-NET PRO2	Description	
	External contact control (Installation option SEG14)	Occupied room control	In close contact (=Occupied room)	Use of R/C in close contact
1	On/Off Control (1)	Enable	On as [setting of Occupied room control]	0
2		Disable	On as [last On operation mode]	0
3	Off only Control (2)	Enable	On as [setting of Occupied room control]	0
4		Disable	Off	0
5	Window Control (3)	Enable	Case1) If Indoor unit was Off at last open contact → Off Case2) If Indoor unit was On at last open contact → On as [setting of Occupied room control]	0
6		Disable	On as [last operation mode]	0

Setting Auto Change Over

The screenshot shows the 'Auto Change Over setting' page in the Samsung DMS2.5 web interface. The page includes a navigation bar with 'System Settings' selected. The main content area is titled 'Auto Change Over setting' and contains several configuration sections:

- Auto Change Over applying:** Radio buttons for 'Apply' (selected) and 'Not apply'.
- Minimum operation mode time:** Radio buttons for '10 (min)', '20 (min)', and '30 (min)' (selected).
- Operating method of Auto Change Over:**
 - Weighted average
 - Representative temperature
 - Cooling/Heating load
 - Selected indoor unit load
- Temperature Settings:**
 - A (Heat Desired Temp.): 20.0°C (18-30°C, Default: 24°C)
 - B (Cool Desired Temp.): 22.2°C (18-30°C, Default: 27°C)
 - C (Heat to Cool): 23.8°C (21-40°C, Default: 29°C)
 - D (Cool to Heat): 18.3°C (1-27°C, Default: 22°C)
- Load Settings:**
 - Heating load: 50% (Minimum percent of the number of indoor units) with a 3°C offset.
 - Cooling load: 50% (Minimum percent of the number of indoor units) with a 3°C offset.
 - Selected indoor unit load: Heating load 3°C < (Desired temp. - Current temp.) and Cooling load 3°C < (Current temp. - Desired temp.).
- Table:**

Outdoor unit address	Outdoor unit name	Group	Exception
11.04.00	SYSTEM-7	1	<input type="checkbox"/>
11.07.00	SYSTEM-6	2	<input type="checkbox"/>
11.09.00	SYS-10	3	<input type="checkbox"/>

At the bottom right, there are '02 Edit' and '03 Save' buttons.

- Click [System Settings] → [Auto Change Over setting] when DMS2.5 web page menu screen appears.
 - Using the 'Auto Change Over' function, DMS2.5 can control indoor units to start auto cooling or auto heating.
 - When using auto cooling or heating, DMS2.5 operates the Fan → Cool or Heat → Auto modes in order. For ERV PLUS, it operates the Fan → Cool or Heat modes in order.

- Click [Edit] to configure the Auto Chang Over settings.

A [Apply] / [Not apply]

- When using the Auto Change Over function, 'A' appears in the [Control and Monitoring] screen on the indoor unit, and the indoor unit cannot control its operation mode separately.

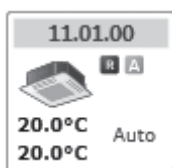

B Minimum operation mode time

- You can select a period of time among 10, 20, and 30 minutes for which the operation mode is maintained after the indoor units are controlled in automatic cooling or automatic heating. However, if you turn the indoor units on or off or change the set temperatures, the internal logic can maintain the operation mode for a time less than the selected time.

C [Weighted average]: Configure the settings so that indoor units automatically switch between cooling and heating modes according to the set temperature, current temperature, and cooling/heating capacity of the indoor units that are turned on.

Let's assume, for example, indoor units of the same capacity have been installed. If a larger number of the units have desired temperature lower than the current temperature, all of the units automatically switch to cooling mode. If a larger number of the units have the set temperature higher than the current number, all of the units automatically switch to heating mode.

D [Representative temperature]: Sets to run auto cooling or heating operation, according to the average temperature of the turned-on indoor units.

- DMS 2.5 sets the indoor units to the auto cooling mode and keeps the temperature according to 'B (Heat Desired Temp)' when the average temperature of the units currently running is higher than 'C (Heat to Cool)'. DMS 2.5 also sets the indoor units to the auto heating mode and keeps the temperature according to 'A (Cool Desired Temp)' when the average temperature of the units currently running is lower than 'D (Cool to Heat)'.

E Cooling/Heating load

- All indoor units that are turned on and belong to an outdoor unit group are controlled in automatic cooling or automatic heating according to the selected heating/cooling load.
- When the heating load is selected, the difference between the set temperature and the current temperature is calculated for all indoor units that are turned on and belong to the same outdoor unit group. If this difference is larger than the set difference and the number of indoor units with this value is equal to or greater than the set percentage, all indoor units belonging to the same outdoor unit group is controlled in automatic heating. If this difference is larger than the set difference and the number of indoor units with this value is less than the set percentage, all indoor units belonging to the same outdoor unit group are controlled in automatic cooling.
- When the cooling load is selected, the difference between the set temperature and the current temperature is calculated for all indoor units that are turned on and belong to the same outdoor unit group. If this difference is larger than the set difference and the number of indoor units with this value is equal to or greater than the set percentage, all indoor units belonging to the same outdoor unit group are controlled in automatic cooling. If this difference is larger than the set difference and the number of indoor units with this value is less than the set percentage, all indoor units belonging to the same outdoor unit group is controlled in automatic heating.

F Selected indoor unit load

- If all indoor units that you selected are turned on and belong to an outdoor unit group, all indoor units belonging to the same outdoor unit group are controlled in automatic cooling or automatic heating according to the selected heating/cooling load for indoor units.
- The difference between the set temperature and the current temperature is calculated for all indoor units that you selected and belong to the same outdoor unit group. If this difference is larger than the set difference for all the selected indoor units and the heating load is selected, all indoor units belonging to the same outdoor unit group are controlled in automatic heating.
- The difference between the set temperature and the current temperature is calculated for all indoor units that you selected and belong to the same outdoor unit group. If this difference is larger than the set difference for all the selected indoor units and the cooling load is selected, all indoor units belonging to the same outdoor unit group are controlled in automatic cooling.

G Outdoor unit setting

- Only Heat Pump outdoor units that support new communication mode appear in the list. However, not listed in the list are the Heat Pump outdoor units that are connected to the Fresh Duct, Hydro Unit, Hydro Unit HT, EHS, DVM CHILLER, or cooling only indoor unit, as these units are not applicable for Auto Change Over.
- The following outdoor units are not displayed in the list: the outdoor units designed solely for cooling and the outdoor units connected to the heating/cooling change-over switch if the switch is set to the cooling only mode or to the heating only mode.
- The conventional indoor and outdoor units connected to ERV interface module, FCU interface module, Heat Recovery, and compatible interface module—those units do not appear in the list, as these units are not applicable for Auto Change Over.
- Auto Change Over works for each group.
- All indoor units in a single group become the targets for calculating Auto Change Over operation, and are controlled to equally run auto cooling or auto heating.
- If you select [Exception], the outdoor unit cannot use the Auto Change Over function despite being grouped, and indoor units connected to the outdoor unit are excluded from the targets for calculating Auto Change Over operation.
- If the outdoor unit is set to cooling or heating only mode, the Auto Change Over function is not available.

3 Click [Save] after finishing the setup.

Note

- In the Auto mode, the indoor units for which the Dual Set Point function is enabled use the automatic heating set temperature or automatic cooling set temperature instead of the single set temperature.
- When the DMS2.5 is installed in the S-Net3, Touch Centralized controller, Wi-Fi Kit product, or wired/wireless remote controllers simultaneously, the indoor unit with the Auto Change Over function cannot control operation modes through S-Net3, Touch Centralized controller, Wi-Fi Kit product, or the wired/wireless remote controller.

Setting Dual Set Point

- 1 Click [System Settings] → [Dual Set Point setting] when DMS2.5 web page menu screen appears.
 - The Dual Set Point function allows you to set the automatic cooling and heating set temperatures only when the indoor unit is in the Auto mode.
 - If you want to use the Dual Set Point function for an indoor unit, the wired remote controller connected to the indoor unit must support the Dual Set Point function and the Dual Set Point function must be also enabled (the Auto Change Over function is enabled for the wired remote controller).
- 2 Click [Edit], and then select whether to enable the Dual Set Point function for each indoor unit.
 - Only the indoor units that support the Dual Set Point function appear on the screen.
- 3 Click [Save].

S-NET3

MST-P3P

Features

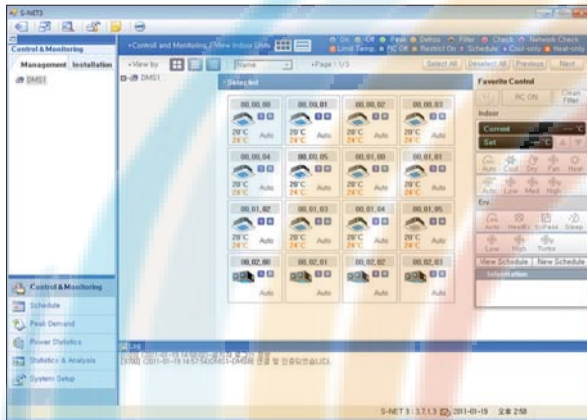

PC program designed to manage system air conditioners in a large site.

- Max. 16 DMS2.5 connection
- Max. 4,096 indoor unit controlling and monitoring
- Integrated management of indoor units, ventilators and AHU(Excluding DVM CHILLER, FCU KIT)
- Manages operation and error history
- Check indoor/outdoor unit cycle data
- Integrated management of peak control in single program

PC specifications

Item	Model	Details
PC	CPU	Pentium 4 or above
	Memory	More than 512MB
	HDD	More than 1Gbyte space available
	Network	10/100M
OS	-	Windows NT, Windows 2000, Windows XP, Windows VISTA, Windows 7

Compatible product

DMS	DMS(MIM-D00AN), DMS(MIM-D01AUN)
-----	---------------------------------

Note

Model	MST-P3P
Number of connection	Max. 16 DMSs

System connection

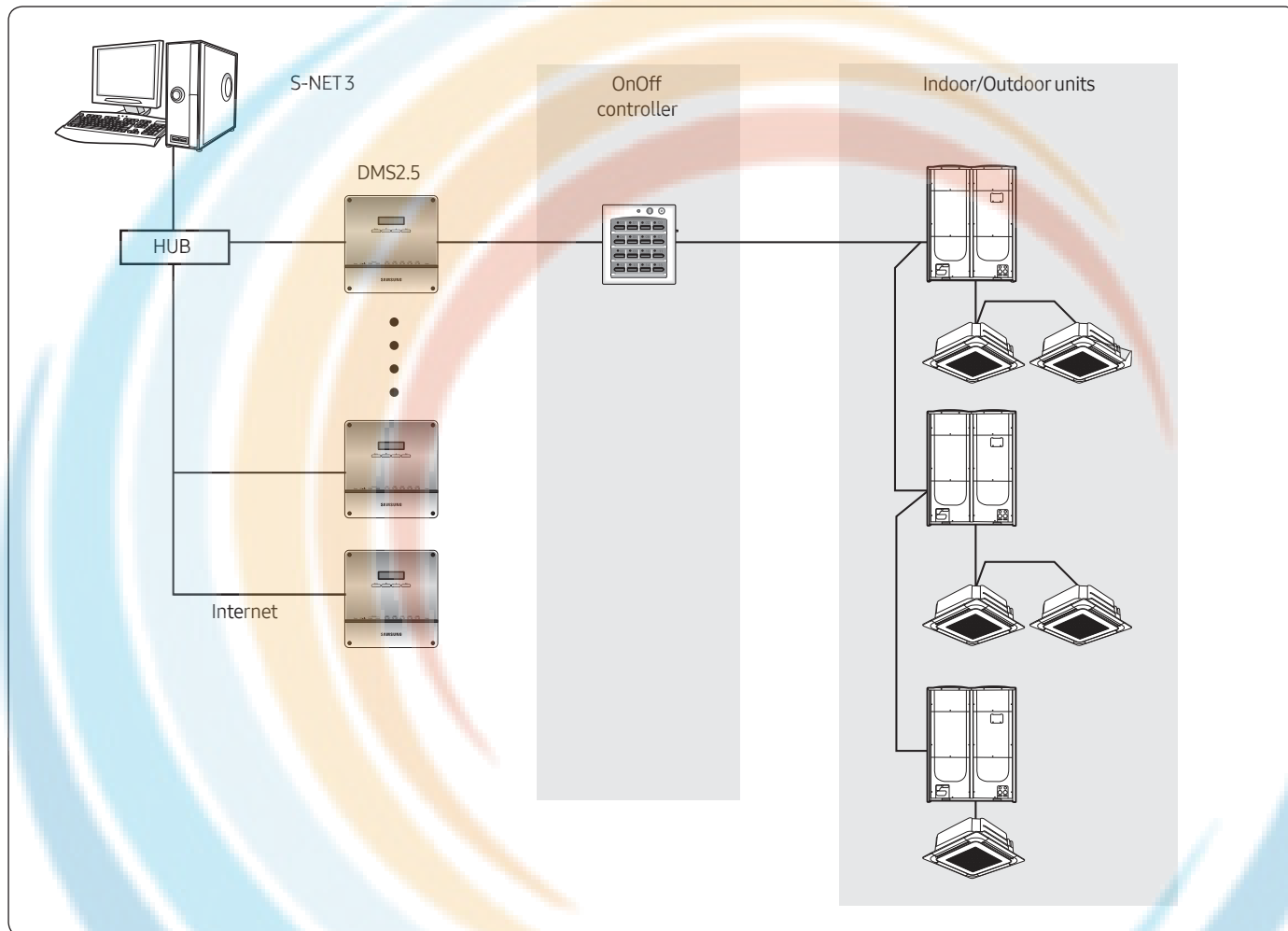

Function**S-NET3 function description**

Control & Monitoring	View the management structure	Control and monitor the indoor units (max. 4,096 units).
	View the installation structure	Check and refer the state of various devices such as indoor/outdoor units, OnOff controller, and I/M.
	Indoor unit/ERV control	Set the operation mode, temperature, fan speed, and fan Control & Monitoring direction of indoor unit/ERV.
	Indoor unit/ERV monitoring	Monitor the status of indoor unit/ERV.
	View outdoor unit	Check the outdoor unit's cycle data and the cycle data of the linked indoor units.
	View DMS2.5	Check the status data of the control unit linked to DMS2.5.
Schedule	Create new schedule	Set new schedule.
	View schedule	Check the schedule of the selected indoor unit.
	Start/Stop schedule	Start/Stop schedule application.
	Store/Call schedule	Store/Call a prepared schedule.
	View daily schedule	Confirm each schedule by date.
	Set common exception date	Set the date which schedule operation is not applied on.
Usage time and power	Usage time and power	Check the usage time and power for total, group, and individual indoor units.
	Power consumption report	For preparing the report on the power consumption by each indoor unit for the period set.
	Power distribution management group edition	Edit an indoor unit's power management structure
	Set the electricity rate section	Set up to 3 sections for electricity billing management.
Statistics and analysis	Indoor unit status	Check the status of indoor unit operation/temperature setting per period.
	Usage time and power	Check the usage time and power for total, group, and individual indoor units.
	Indoor unit usage	The usage ratio of all indoor units for a specific period.
System management	Set environment	Set the environment related to S-NET3 (password, language, temperature unit).
	Set DMS2.5	Set the DMS2.5 to connect with S-NET3.
	Refer event log	Refer the warning, error, data of indoor units.
	Renew installed device information	Modify S-NET3 data if installation data has been changed.
	DMS2.5 backup/restore	Backup the data of DMS2.5 connected to S-NET3.
	S-NET3 backup/restore	Backup the data of S-NET3.

Userfunctions

Manage a range of functions accessible to different types of users such as regular user, administrator and installer.

	User	Administrator	Installer
View the total indoor unit	0	0	0
Structure editing	X	0	0
The list of installed devices	X	0	0
Whole indoor unit stop	0	0	0
Indoor unit/ERV control/Monitoring	0	0	0
View the management structure	0	0	0
View the installation structure	X	0	0
View outdoor units, DMS2.5	X	0	0
Schedule	X	0	0
Indoor unit operation setting	X	0	0
Usage time and power	X	0	0
Power consumption report	X	0	0
Power distribution management group edit	X	0	0
Power distribution section setting	X	0	0
Statistics/Analysis	X	0	0
S-NET3 setting	X	0	0
DMS2.5 setting	X	0	0
Event log reference	X	0	0
Tracking	X	0	0
DMS2.5 restoration	X	0	0
DMS2.5 backup	X	0	0
S-NET3 restoration/backup	X	0	0

Detail function description

S-NET3 display

Log-in

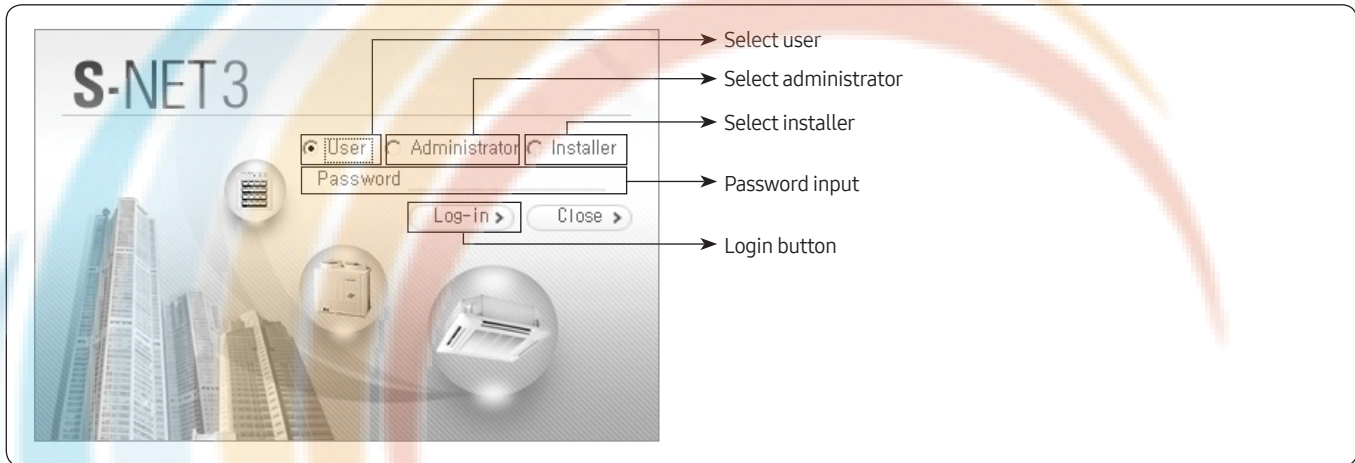

Control and monitoring

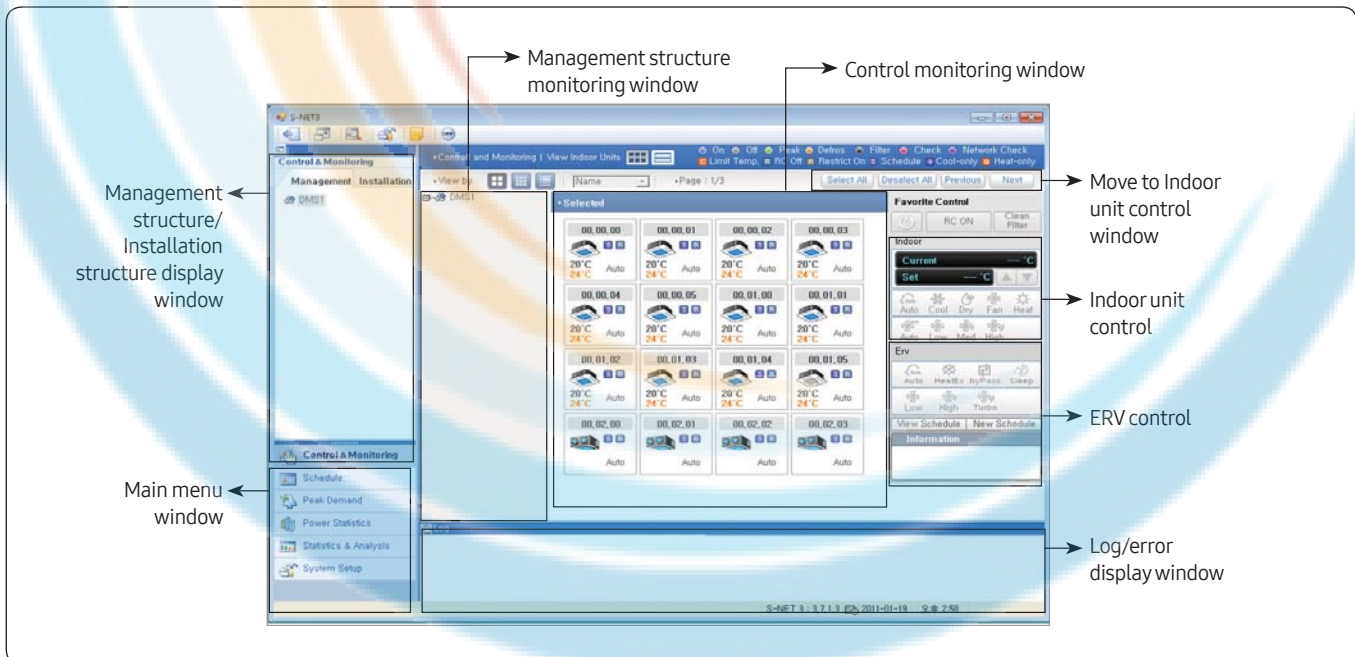

Installation structure window

Select the installation structure tab then select DMS2.5 connected to S-NET3; it is possible to see the program version, status of the selected DMS2.5, the program version and communication status of OnOff controller. If indoor or outdoor unit is selected at the installation structure, it is possible to check the hardware information of the selected device.



Selecting management structure

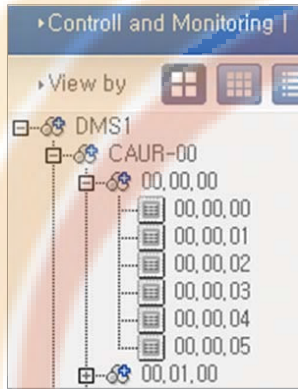

Selecting installation structure

A When DMS2.5 & OnOff controller are selected.

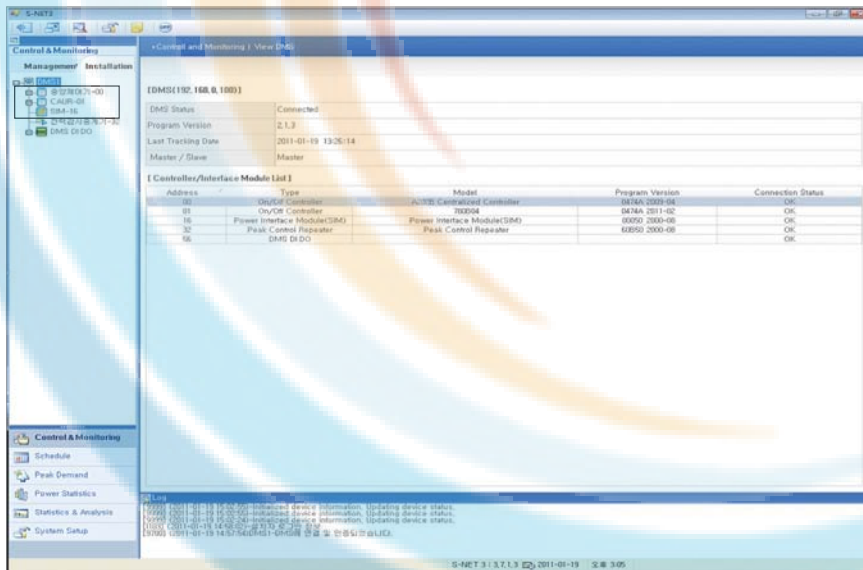

- DMS2.5 status, DMS2.5 program version, last tracking date and Master/Slave setting state.
- Displays model name, software version, communication state of centralized controller, PIM.

B When outdoor unit is selected

Temperature: °C Pressure: kg/㎥
 (DMS : DMS1-00,00 - Master)

Comp 1		Comp 2		Comp 3	
Start	Start	Start	Start	Start	Start
Defrost status information	--	Suction temperature	20°C	Operation Status	On standby
Oil temperature	10°C	Low pressure data	3kg/㎥	Operation Mode	On standby
Condenser temperature	0°C	High pressure data	17kg/㎥	Discharge temperature	22°C
Oil balancing	--	Oil recovering	--	Operation Status (start-up)	-
Condenser outlet temperature	33°C	Outdoor temperature	25°C	Error	-
Outdoor main expansion valve step	300 STEP	Sum of operating IDU capacity	0.5 kW	Rate of operating IDU capacity (Heating)	0.00%
Outdoor Model	DVM-3 or 4 HeatPump B136 Interface Module	Outdoor Version	0676B 2009-03	Double tube temperature	30°C
Discharge-2 temperature	22°C	Discharge-3 temperature	22°C	Outdoor Fan Step	30STEP
Running currents (Comp. 1)	10A	Running currents (Comp. 2)	10A	Outdoor Option Data	10HP
Main cooling valve	On	EVI bypass valve	On	Running currents (Comp. 3)	10A
Hot gas valve	On	Liquid bypass valve	On	4way valve	On
EVI EEV (Liquid EEV)	300STEP	HR EEV(Gas Liquid EEV)	300STEP	Loading time	5Sec
Crank case heater 1	On	Crank case heater 2	On	Accumulator CCH	On
		Crank case heater 3	On		

- Outdoor unit cycle data, outdoor unit model, interface module model and interface module program version is displayed.

C When indoor unit is selected

*Selected

Address	Name	RMC	
00,00,00	00,00,00	00	
Operation Mode	Auto	Current Temp.	20°C
On/Off	On	Desired Temp.	24°C
Desired Capacity	0.1 kW	EEV	120STEP
Eva In Temp.	50°C	Eva Out Temp.	50°C
Error Status	-	Human Sensor	-
Discharge T(Heat)	-	Discharge T(Cool)	-
Humidification	-	Model	2 Way Type
			Auto Clean
Address	00,00,01	Name	00,00,01
Operation Mode	Auto	Current Temp.	20°C
On/Off	On	Desired Temp.	24°C
Desired Capacity	0.1 kW	EEV	120STEP
Eva In Temp.	50°C	Eva Out Temp.	50°C
Error Status	-	Human Sensor	-
Discharge T(Heat)	-	Discharge T(Cool)	-
Humidification	-	Model	2 Way Type
			Auto Clean
Address	00,00,02	Name	00,00,02
Operation Mode	Auto	Current Temp.	20°C
On/Off	On	Desired Temp.	24°C
Desired Capacity	0.1 kW	EEV	120STEP
Eva In Temp.	50°C	Eva Out Temp.	50°C
Error Status	-	Human Sensor	-
Discharge T(Heat)	-	Discharge T(Cool)	-
Humidification	-	Model	2 Way Type
			Auto Clean
Address	00,00,03	Name	00,00,03
Operation Mode	Auto	Current Temp.	20°C
On/Off	On	Desired Temp.	24°C
Desired Capacity	0.1 kW	EEV	120STEP
Eva In Temp.	50°C	Eva Out Temp.	50°C
Error Status	-	Human Sensor	-
Discharge T(Heat)	-	Discharge T(Cool)	-
Humidification	-	Model	2 Way Type
			Auto Clean
Address	00,00,04	Name	00,00,04
Operation Mode	Auto	Current Temp.	20°C

- Indoor unit operation status, indoor unit cycle data and indoor unit model code is displayed.

S-NET3 > MST-P3P

Control

- Control indoor unit/ERV through the control window that appears on the screen.
- Control total indoor units, the operation mode of indoor units, multiple selection, temperature, fan speed, and fan direction.
- Set Upper/Lower temperature limit so that temperature cannot be set outside of the limited temperature range.
- Enable/disable remote control usage.
- Check the schedule of the selected indoor unit.

A Deselect device



B Selecting indoor unit and ERV together

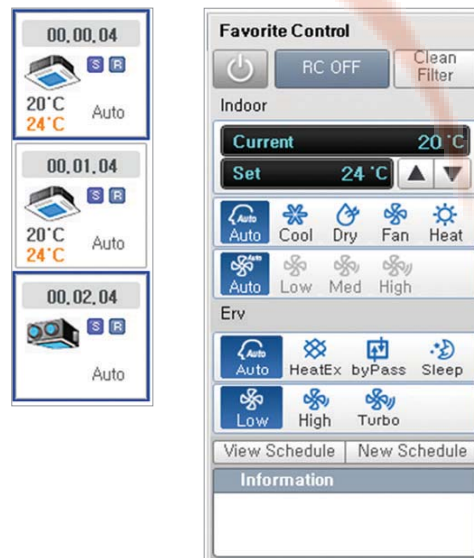

C Selecting indoor unit



D Selecting ERV

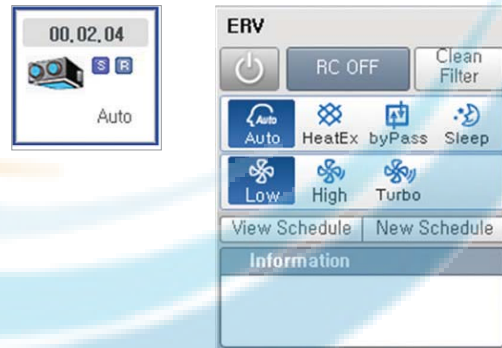

Schedule control

A Schedule setting

- Able to set a schedule to control indoor units and ERVs. (creating, modifying, deleting).
- Able to set weekly, daily, one day schedule.
- Able to control the operation mode, temperature setting, fan speed, fan direction during the schedule control.

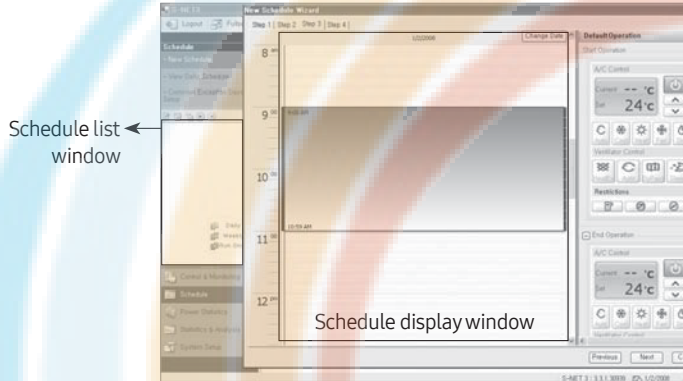

- Easy schedule control for user with the wizard method (step-by-step setting).

1 The 1st step (select a schedule mode)

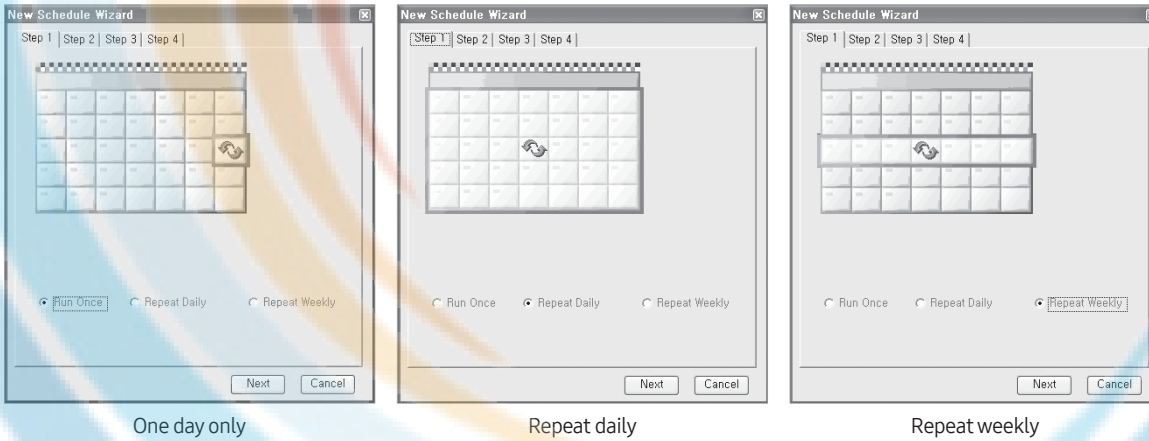

2 2nd step (select the indoor units to apply a schedule to)

- Display the total indoor units in S-NET3.
- Able to select individual indoor units, OnOff controller, DMS2.5.

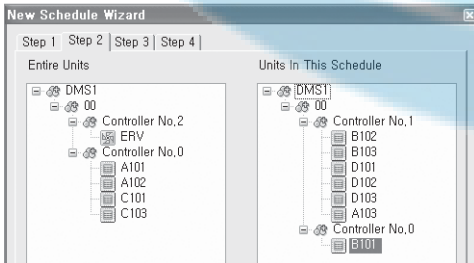

S-NET3 > MST-P3P

3 The 3rd step (schedule operation setting)

- Set up time by dragging on the time table.
- Set the schedule with the control panel on the right. (Operation mode, temperature setting, fan speed, fan direction and remote control use).
- Click the schedule time setup window to display a schedule modification window (able to modify a schedule time, operation mode and temperature setting).

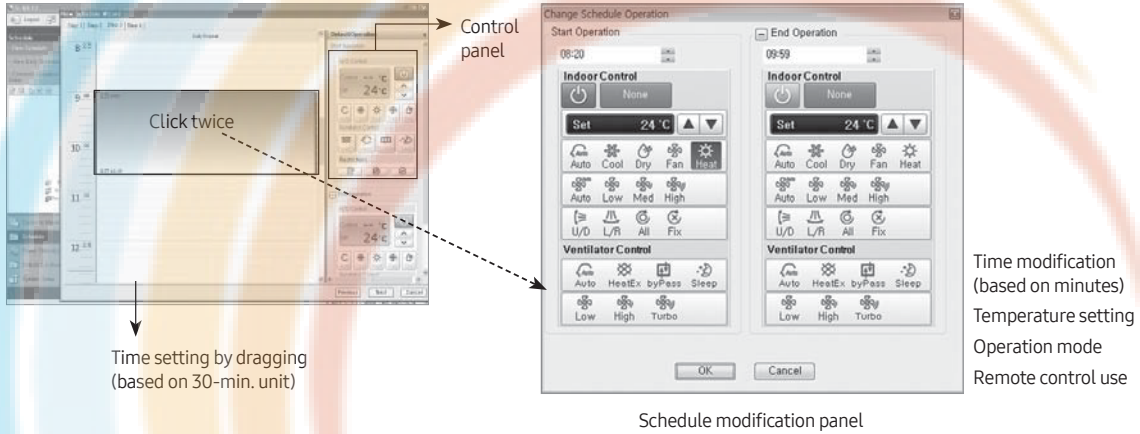

4 The 4th step (Schedule period and exception date setting)

- Click the date on the calendar to set the date (once selected, the designated date is displayed in red).

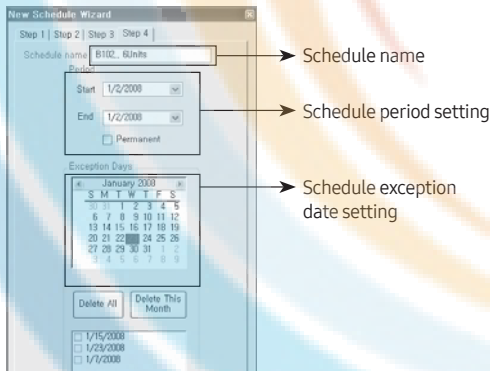

5 Schedule setting completion

- Displays a schedule list to be automatically applied to the schedule

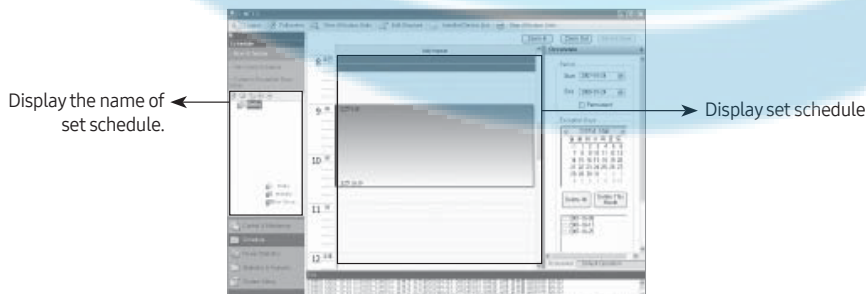

S-NET3 > MST-P3P

B Schedule control

- Click the set schedule display window twice to display the modification panel. Then it is possible to modify various functions such as schedule time, operation mode and temperature setting.
- Able to carry out various functions such as a schedule name change, schedule delete, indoor unit addition and deletion with the icons on the left menu window.

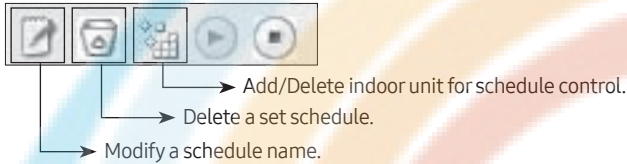

Usage time and power consumption

A Usage time and power

- Able to search for the power consumption and usage time by different conditions including the total indoor units applied to S-NET3, OnOff controller, individual indoor unit. OnOff controller, individual indoor unit.



Total indoor unit usage reference

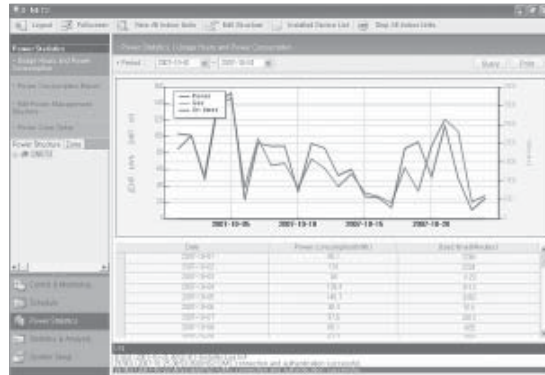

Individual indoor unit usage reference

B Power consumption report

- Able to print out the amount of power consumed for a specific period of time in the form of report.
- The applicable formats include PDF, TXT, HTML, CSV, MHT, EXCEL, graphic documents.

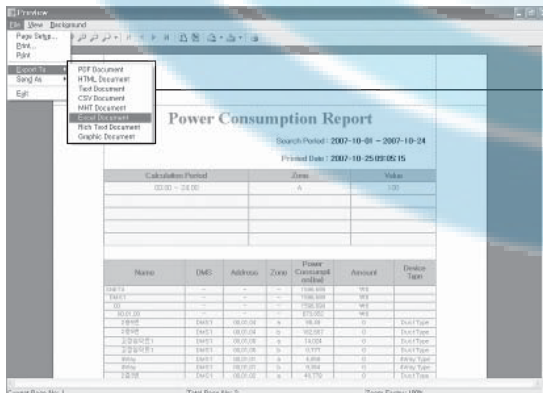

Types of document to be stored

C Power management structure editing

- Just as the structural editing at the monitoring, power management can be restructured to ensure greater convenience for administrators.
- Once the power management structure is edited, power consumption report and usage can be referred in the edited formats.

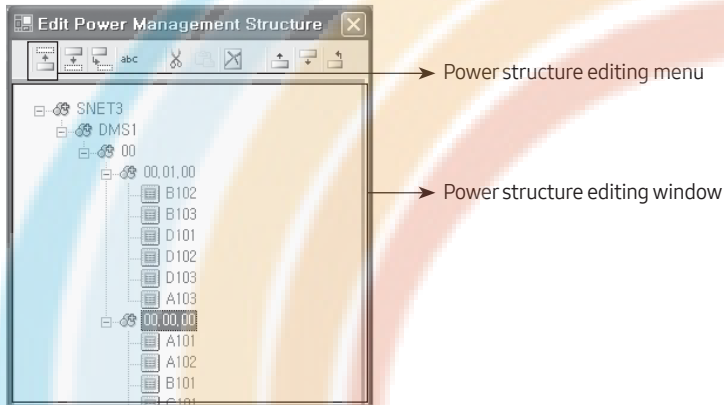

D Power section setting

- It can be referred and divided into max. 3 sections for power consumption reference.
- It is possible to refer or prepare reports for usage time and power consumption by dividing section by each hour.

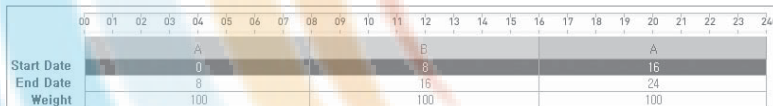

↓
Able to adjust the sections by inputting relevant time.

Statistics and analysis

A Indoor unit status

- Able to see the operation status of selected indoor units and room temperature for the present and the past.
- Able to refer to the operation status for the last two days. If the reference day is out of range, an error message window will appear.

Select indoor unit

Hourly indoor unit operation and temperature display

Input start-date again. (Can inquire yesterday and today)

Display errors if the wrong period has been set

B Power consumption of indoor units

- Displays the use time and power consumption ratios for the indoor units connected to each DMS2.5.

DMS2.5 selection

Period reference

Device Name	Device Addr	Demand Power	On Time(%)	On Time(Minute)	Model
1	00:00:00	0.0000	0.0000	0	0
2	00:00:00	0.0000	0.0000	0	0
3	00:00:00	0.0000	0.0000	0	0
4	00:00:00	0.0000	0.0000	0	0
5	00:00:00	0.0000	0.0000	0	0
6	00:00:00	0.0000	0.0000	0	0
7	00:00:00	0.0000	0.0000	0	0
8	00:00:00	0.0000	0.0000	0	0
9	00:00:00	0.0000	0.0000	0	0
10	00:00:00	0.0000	0.0000	0	0
11	00:00:00	0.0000	0.0000	0	0
12	00:00:00	0.0000	0.0000	0	0
13	00:00:00	0.0000	0.0000	0	0
14	00:00:00	0.0000	0.0000	0	0
15	00:00:00	0.0000	0.0000	0	0
16	00:00:00	0.0000	0.0000	0	0
17	00:00:00	0.0000	0.0000	0	0
18	00:00:00	0.0000	0.0000	0	0
19	00:00:00	0.0000	0.0000	0	0
20	00:00:00	0.0000	0.0000	0	0
21	00:00:00	0.0000	0.0000	0	0
22	00:00:00	0.0000	0.0000	0	0
23	00:00:00	0.0000	0.0000	0	0
24	00:00:00	0.0000	0.0000	0	0

DMS2.5 selection

System management

A Environment setting

- Set the environment of S-NET3.
- Set administrator password, language, temperature unit, default value for indoor unit, etc.
- Determine if peak power will be displayed or not in the menu setting (Korean market only).



Language setting
 Log date view setting
 Temperature unit setting: It is set automatically depending on indoor unit.

B DMS2.5 setting

- Set the DMS2.5 to connect with S-NET3.
- Click Save after inputting IP and passwords (1) and it will attempt to make communication with S-NET3 and DMS2.5 then display normal when communication is made.

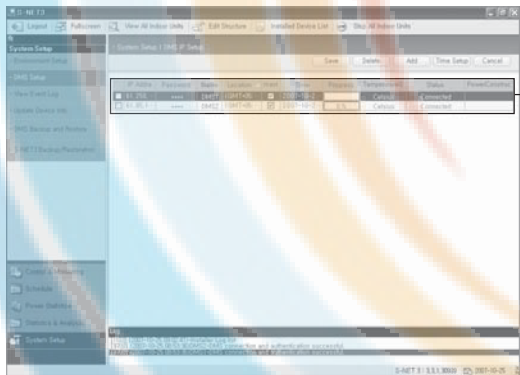

DMS2.5 setup window

When a DMS2.5 to connect with S-NET3 is added
 DMS2.5 time setting

IP Addr	Password	Name	Location	Time	Progress	TemperatureS	Status	PowerConstruc
61.250...	****	DMS1	(GMT+05:...	2007-10-2		Celsius	Connected	
61.85.1...	****	DMS2	(GMT+05:...	2007-10-2	0%	Celsius	Connected	

DMS2.5's access IP input
 Password input

Note

- DMS2.5 has two passwords. One is a password needed to connect to a DMS2.5 web client (set at the user management), the other is necessary to make access to S-NET3 (set at the system environment).
- When the wrong password for S-NET3 is input, a message indicating DMS2.5 – account recognition failure appears.

S-NET3 › MST-P3P

C View event log

- Able to check various information such as indoor/outdoor units connected to S-NET3, control device error/warning, information details by date.

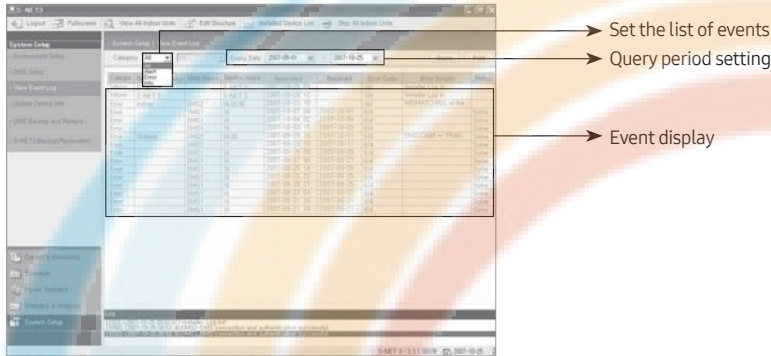

D Information update of the installed device

- Able to carry out information update or tracking for the installed device.
- Tracking involves receiving data from DMS2.5 after tracking it so as to renew data, whereas data renewal involves correcting data from DMS2.5 after receiving data without DMS2.5 tracking.



E S-NET3 backup and restoration

- Able to backup and restore data of S-NET3.
- Backup involves in backing up all data in S-NET3. Thus, if backup data is restored in a PC where S-NET3 is installed, it will produce the same environment that is previously used.



S-NET3 log information

Log	Contents
E9000	Connection impossible
E9001	Connection denied
E9002	Connection finished
E9010	WINK denied
E9011	DMS2.5 password authentication failure
E9012	Serial exchange failure
E9100	General error on instruction transmission
E9150	Attempt to transmit to a DMS2.5 not in connection
E9151	Attempt to transmit to a DMS2.5 not registered
E9200	General error on response acceptance
E9250	There is no response to the requested command due to DMS2.5 failure and/or network delay
E9300	XML generating
E9400	XML parsing
E9401	Installation information on S-NET3 and DMS2.5 does not match, check tracking information
E9999	Initialized device information updating device status
I101	Common user log in
I102	Administrator user log in
I103	Installer log in
I104	Log in
I105	Log out
I201	Tracking
I202	Request to tracking
I301	Request to schedule change
I801	Insert DMS2.5
I802	Delete DMS2.5
I803	DMS2.5 time setting
I9700	DMS2.5 connection and authorization successful
I9701	Reconnection
I9801	Emergency stop

Chapter 04

Gateway

BACnet Gateway	
MIM-B17BUN	187
LonWorks Gateway	
MIM-B18BUN	214
External Contact Interface Module	
MIM-B14.....	233
PIM (Pulse Interface Module)	
MIM-B16UN	238
Interface module	
MIM-N01.....	250
FCU interface module	
MIM-F10N	259

BACnet Gateway

MIM-B17BUN

Features

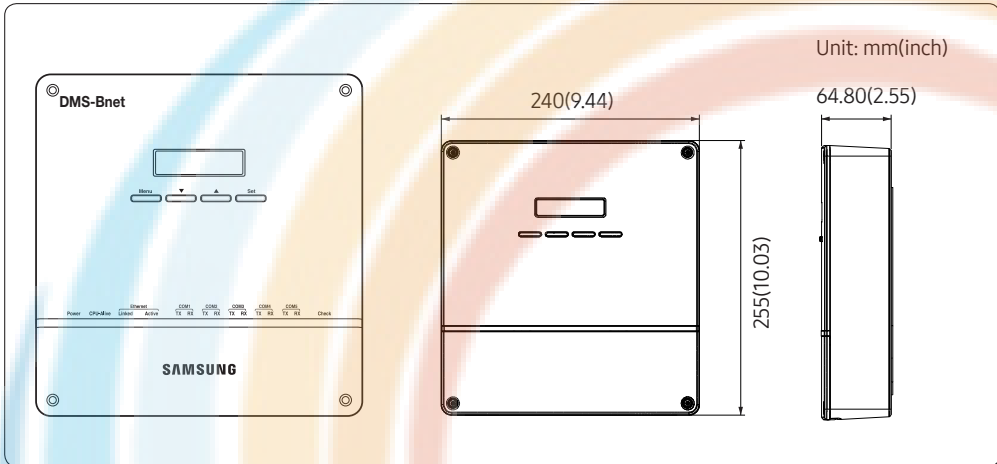

- For BACnet protocol system Support DMS2.5 control function at the same time.

Product specification

Power supply	Source	DC Adaptor		
	Input	100~240VAC (±10%), 50/60Hz		
	Output	12V 3A		
Operating temperature range		-10°C ~ 50°C (14°F~122°F)		
Operating humidity range		10%RH ~ 90%RH		
Communication connection		<ul style="list-style-type: none"> • Lower layer: RS485 x 5 • Upper layer: Ethernet100Base-T x 1 		
External connection port	Digital Output	8		
	Digital Input	10		
Maximum length of connection	RS485	1000m (3280ft)		
	Digital Output	100m (328ft)		
	Digital Input	100m (328ft)		
	Ethernet	100m (328ft): When there is no repeater		
Max. connectable number of device	Control layer	Device	Numbers per each channel	Total number for 5 channels
		Indoor units (including ERV, MCU, FCU KIT)	128	256
		Outdoor unit (including MIM-N01, MIM-N10, MIM-F10N, DVM CHILLER unit)	16	80
		OnOff controller	Total 15	Total 75
		Touch centralized controller		
		PIM interface module (MIM-B16UN)	8	8
		Wi-Fi kit (MIM-H03UN)	1	5

BACnet Gateway > MIM-B17BUN

Compatible product

Outdoor unit	AM****X****
Controller	OnOff controller (MCM-A202DUN)
	Touch centralized controller (MCM-A300UN)
	PIM interface module (MIM-B16UN)
	Wi-Fi kit (MIM-H03UN)

- Conventional communication outdoor unit requires compatible interface module (MIM-N01) to establish connection
- MIM-B13D, MIM-B13E, MIM-B04A Interface modules cannot be connected.
- To connect ERV, MIM-N10 is required.
- To connect FCU KIT, MIM-F10N is required.
- Conventional PIM must connect to CH4(COM5) of DMS2.5.

Description of parts

Front

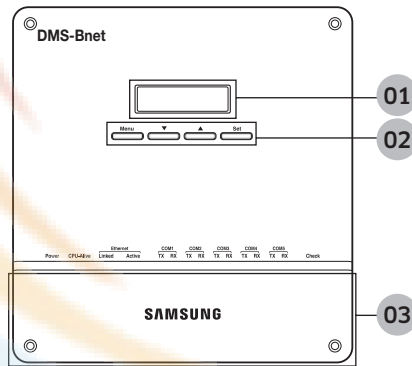

No.	Item	Function
01	LCD display	Displays current time or menu.
	Menu button	Access the setting menu.
02	▼/▲ button	Select function or setting item in the setting menu.
	Set button	Enter or check setting item in the setting menu.
03	Bottom cover	Unscrew 2 screws on the bottom to remove the cover and check the cable connections.

LED indicator

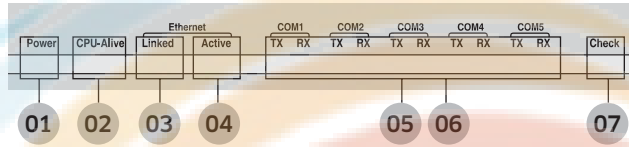

No.	Item	Name	Status
01	Power	Power indicator	Turns blue when the power is supplied
02	CPU Alive	CPU operation indicator	Blinks in orange with 1 second intervals during normal operation
03	Ethernet-Linked	Internet connection indicator	Turns green during normal connection
04	Ethernet-Active	Internet data transmission/reception indicator	Blinks in orange during normal transmission/reception
05	COM1~5 – TX	Channel 1~5 OnOff controller/Interface module Data transmission indicator	Blinks in green during normal transmission
06	COM1~5 – RX	Channel 1~5 OnOff controller/interface module Data reception indicator	Blinks in green during normal reception
07	Check	Indoor/Outdoor unit Communication status indicator	Turns green when communication error occurs

Bottom

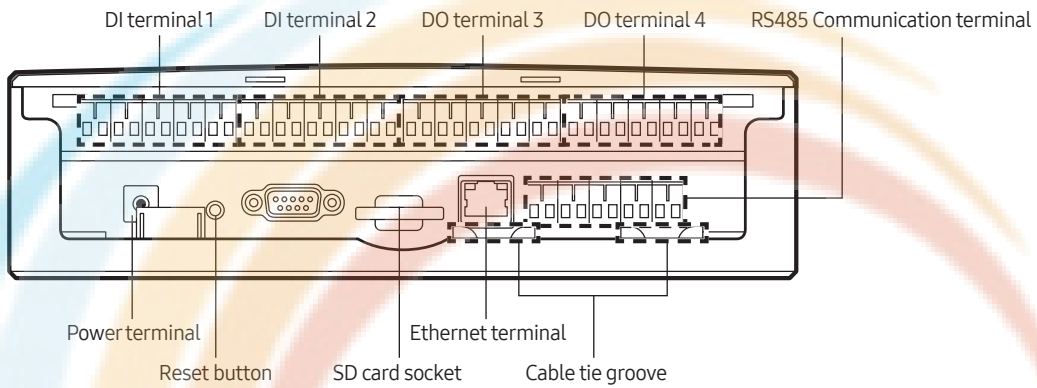

Name	Description
DI terminal 1	Digital Input connection terminal, Channel 1~Channel 5
DI terminal 2	Digital Input connection terminal, Channel 6~Channel 10
DO terminal 3	Digital Output connection terminal, Channel 1~Channel 5
DO terminal 4	Digital Output connection terminal, Channel 6~Channel 8
Reset button	Reset BACnet Gateway
SD card socket	Sub memory (for program update and set information saving) socket
RS485 communication terminal	RS485 port for communication with OnOff controller/interface module
Ethernet Terminal	Connect LAN cable
Cable tie groove	Groove for arranging cables

BACnet Gateway > MIM-B17BUN

Connection diagram

MIM-B16UN(PIM) can be connected with outdoor units or controllers to same channel of DMS2.5.

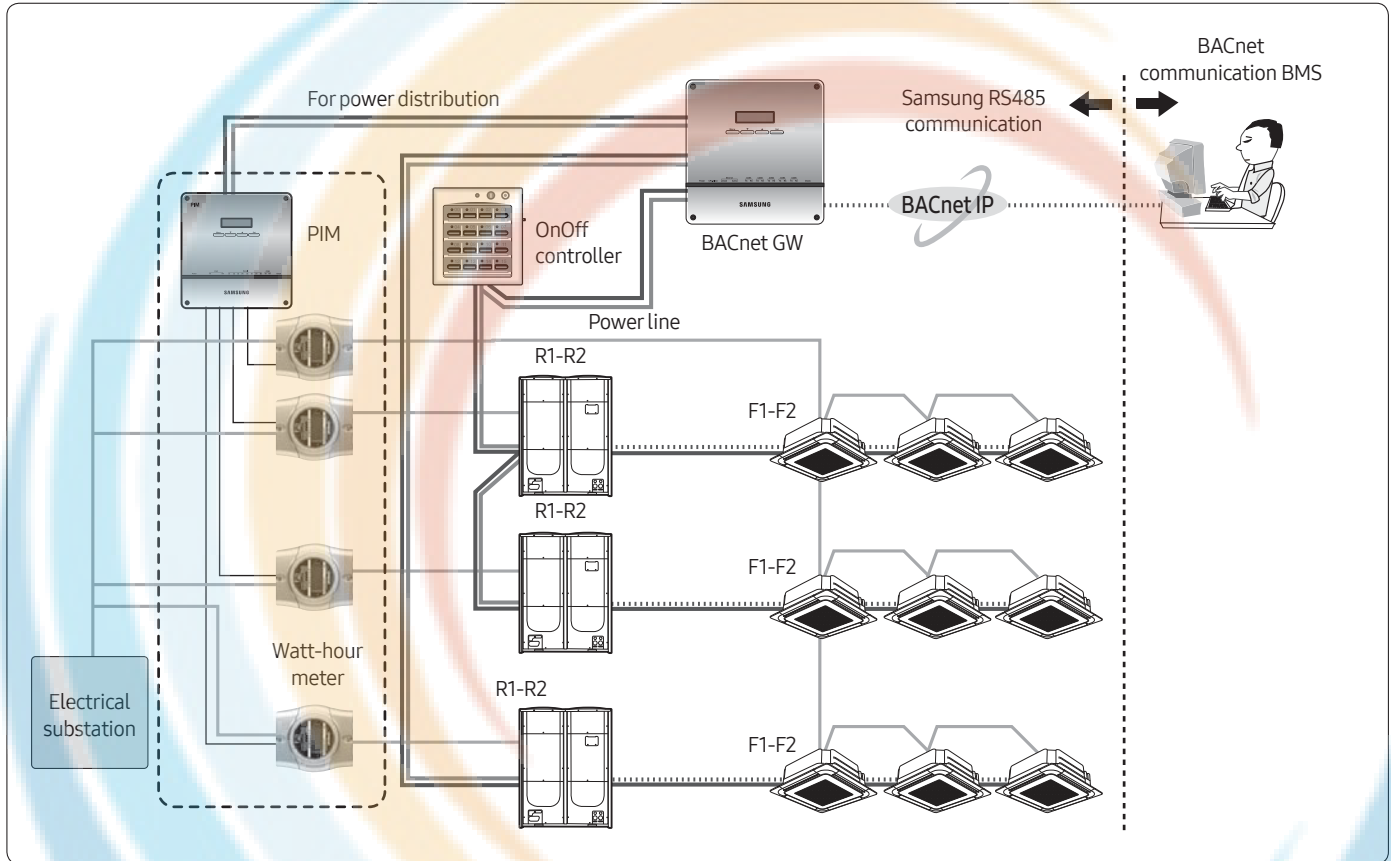

Wiring

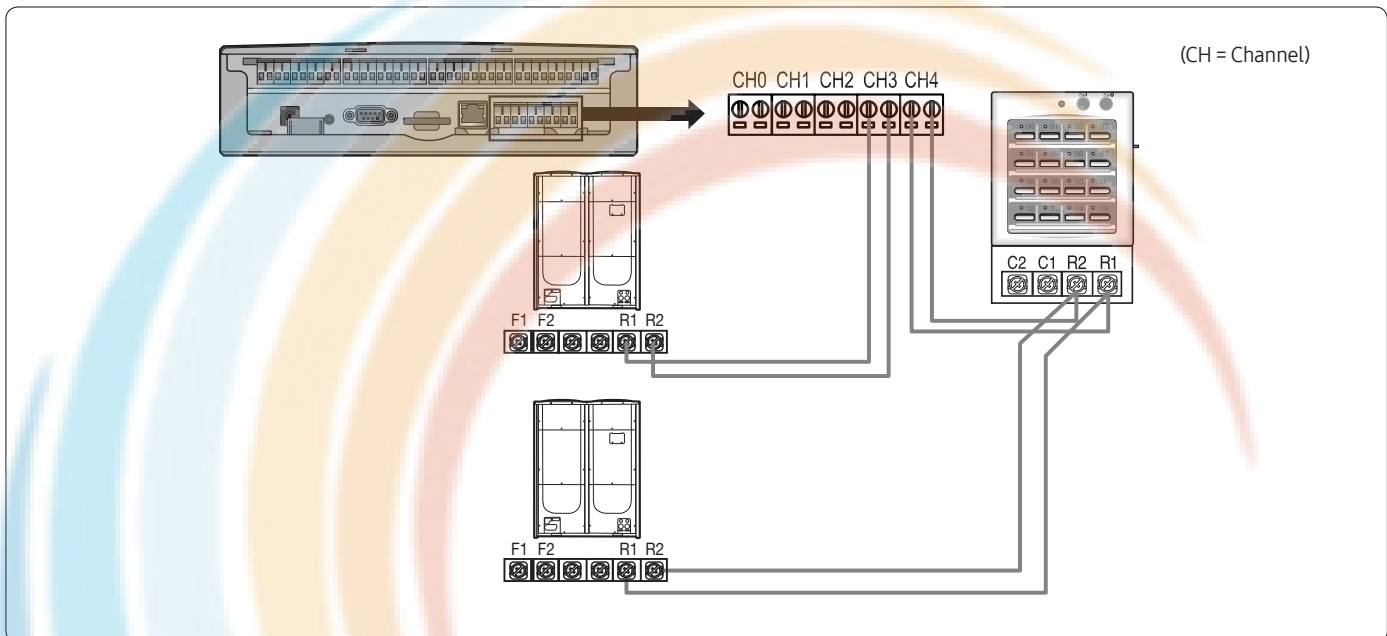

- **Connecting outdoor unit directly**
 - Maximum 16 outdoor units can be connected to each channel
 - Total 80 outdoor units can be connected
- **Connecting OnOff controller/Touch centralized controller**
 - Maximum 15 OnOff controller/Touch centralized controller can be connected to each channel

 **Note**

- BACnet gateway can connect outdoor unit and OnOff controller/Touch centralized controller at the same time.
- Outdoor unit and OnOff controller/Touch centralized controller can be connected to 1 communication channel at the same time.

BACnet Gateway > MIM-B17BUN

Connecting with outdoor unit

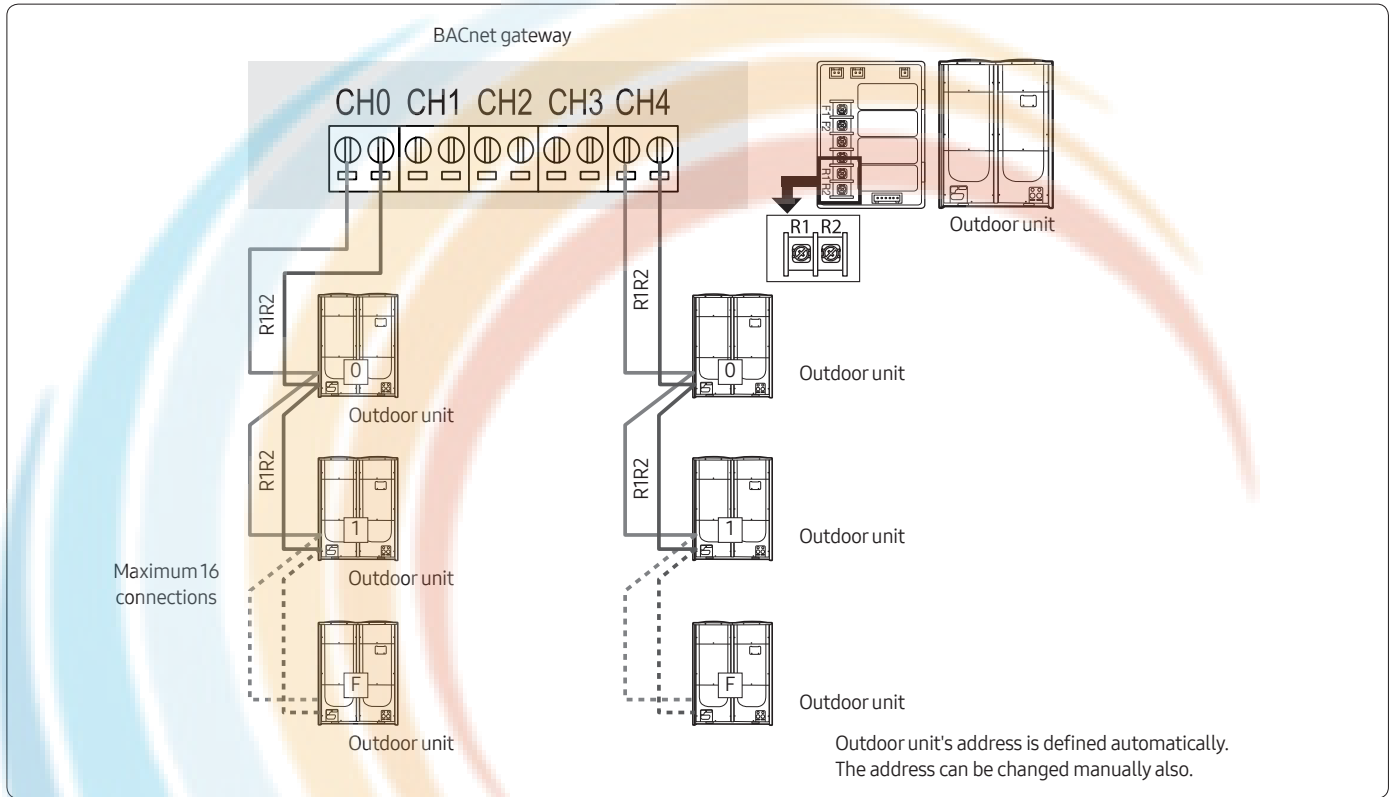

Connecting with OnOff controller

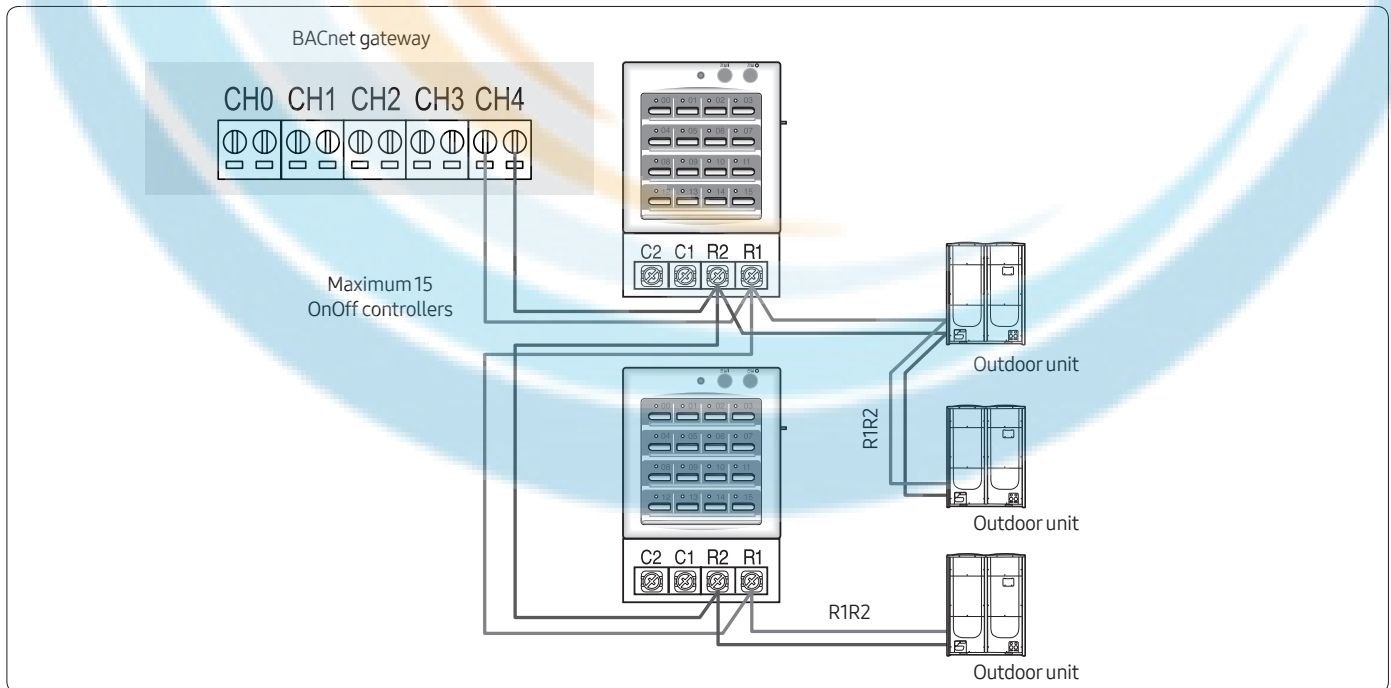

BACnet Gateway > MIM-B17BUN

Connecting with outdoor unit and OnOff controller

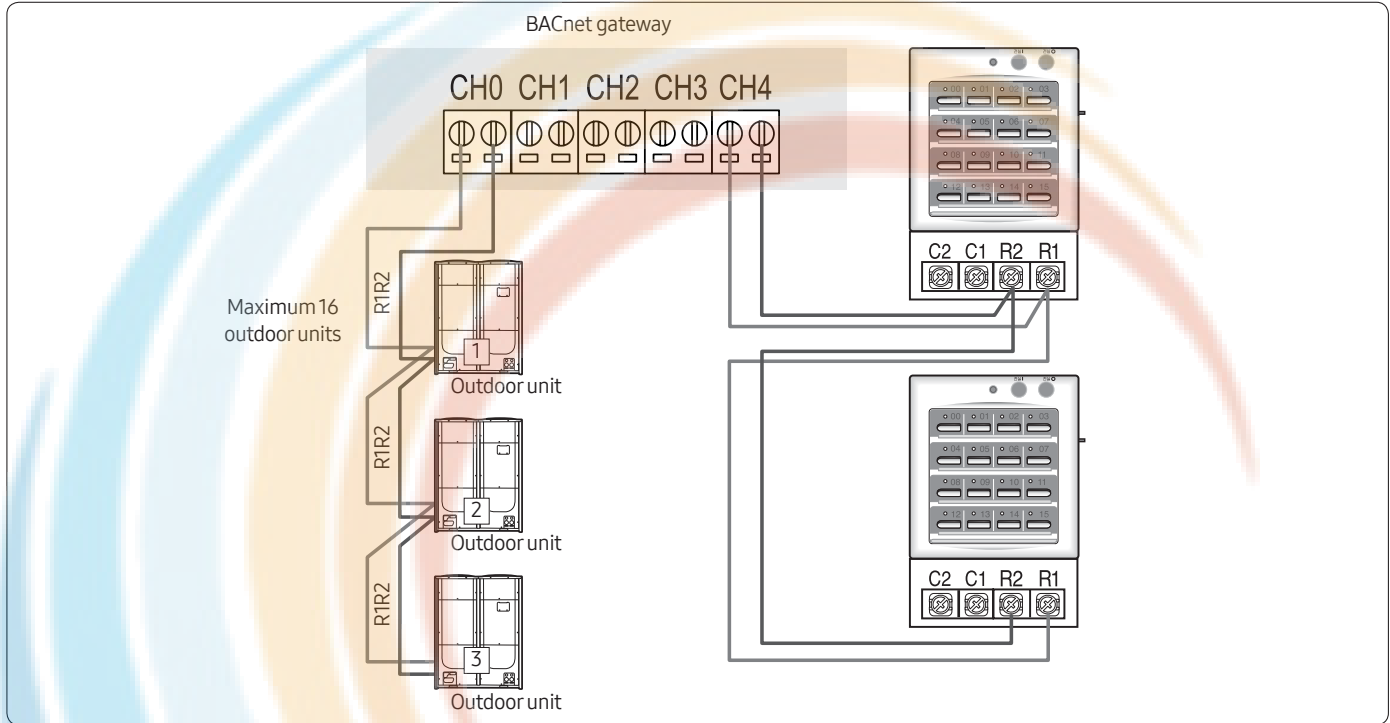

Wiring distance

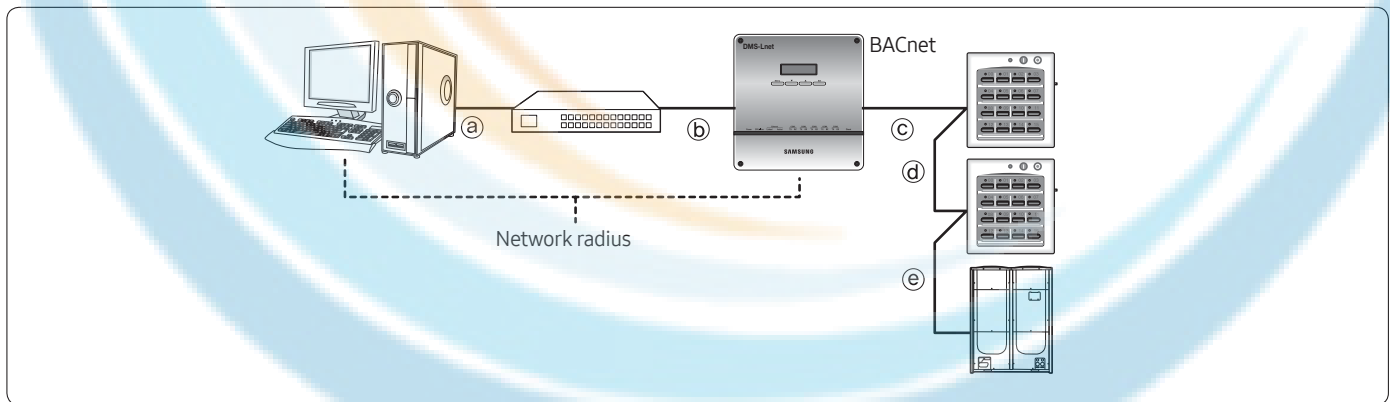

Distance between BACnet gateway and OnOff controller/outdoor unit

- Distance from the BACnet gateway to the furthest device cannot exceed 1000m(3280ft).
- © + @ + © ≤ 1000m(3280ft)

Distance between BACnet gateway and upper level controller

- Since BACnet gateway supports 100 Base-T Ethernet, first repeater or upper level controller from the BACnet gateway cannot be further than 100m(328ft) (IEEE 802.3). Therefore, maximum network radius is restricted to 500m(1640ft).

BACnet Gateway > MIM-B17BUN

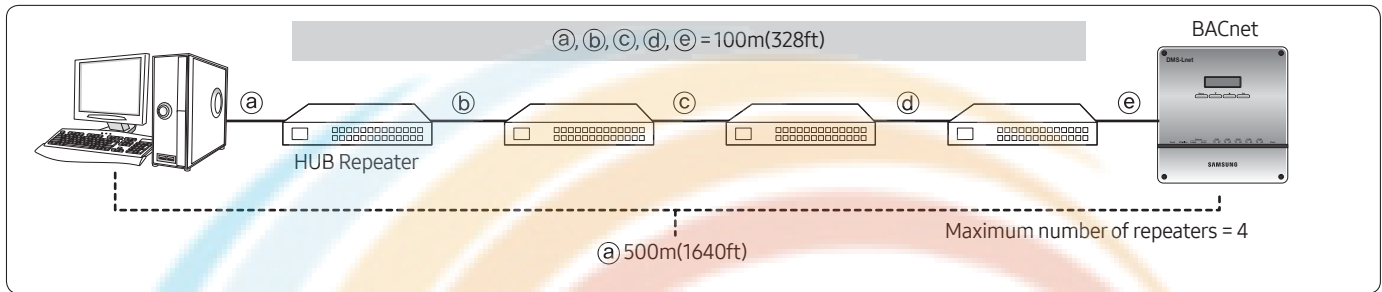

Description of device ID

Item	DNET – Range [Digit 2]	CPP – Range [Digit 3]	INDOOR – Range [Digit 2]
OnOff Controller	1~40	000~015	64
PIM	1~40	100~115	64
DMS DI/DO	1~40	300~315	64
Interface Module	1~40	400~655 (16 x 16)	64
Indoor Unit, ERV AHU kit, EHS	1~40	400~655	0~63
Gateway	1~40	900	64

- Ex) • Indoor Unit
 • DNET (Gateway number): 9
 • Indoor Unit Address: 01.01.32
 • Device ID: 941732

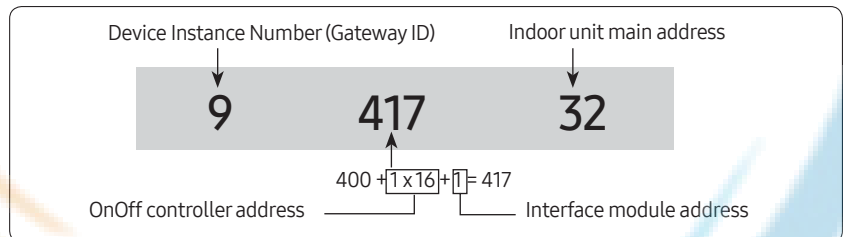

Checking device ID from BACnet Gateway

- Click 'Object ID' from the 'Object ID' column. Detail information window will appear and detail information will be displayed.

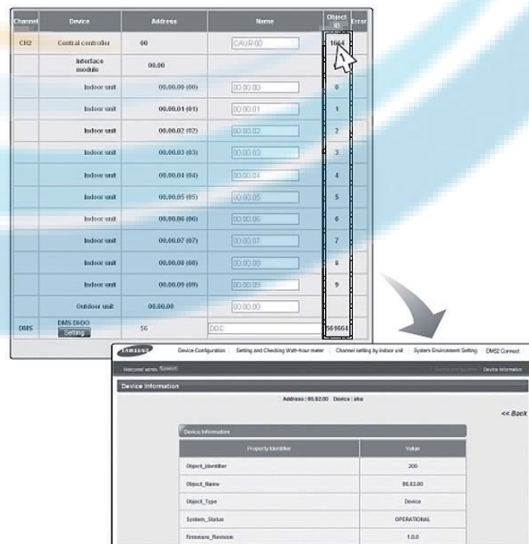

BACnet Point List

The BACnet point list varies depending on which [BACnet point provision type] is selected in the [System Settings] menu.

There are two BACnet point provision types:

- (1) Basic: Reflects the default points.
 - (2) Advanced: Reflects updated points.
- For details, refer to the point list below.

Indoor Unit [Basic]

Single indoor unit has following point list.

Instance Number	Object	Object Type	Object Name	Unit	Status value				
				Inactive	Active				
				Text-1	Text-2	Text-3	Text-4	Text-5	
1	Indoor Temperature	AI	AC_RoomTemp_xx_xxxxxx	°C					
2	Set temperature	AV	AC_Temp_Set_xx_xxxxxx	°C					
3	Setting lower temperature limit	AV	AC_Cool_LimitTemp_xx_xxxxxx	°C					
4	Setting upper temperature limit	AV	AC_Heat_LimitTemp_xx_xxxxxx	°C					
5	The power value of an indoor unit after the basic date	AI	AC_Baseline_kWh_xx_xxxxxx	kWh					
6	The number of hours usage of an indoor unit after the basic date	AI	AC_Baseline_Minute_xx_xxxxxx	Minute					
7	Power value within period	AI	AC_Period_kWh_xx_xxxxxx	kWh					
8	The number of hours usage of an indoor unit within period	AI	AC_Period_Minute_xx_xxxxxx	Minute					
**9	Power On/Off	BV	AC_Power_xx_xxxxxx	Off	On				
10	Applying lower temperature limit setting	BV	AC_Cool_Limit_set_xx_xxxxxx	FALSE	TRUE				
11	Applying upper temperature limit setting	BV	AC_Heat_Limit_set_xx_xxxxxx	FALSE	TRUE				
**12	Filter sign status	BI	AC_FilterSign_xx_xxxxxx	FALSE	TRUE				
**13	Filter sign reset	BO	AC_FilterSign_Reset_xx_xxxxxx	FALSE	TRUE				
**14	Operation mode status	MV	AC_Operation_Mode_xx_xxxxxx	Auto	Cool	Heat	Fan	Dry	
*15	Fan speed status	MV	AC_FanSpeed_xx_xxxxxx	Auto	Low	Mid	High	Turbo	
*16	Air flow direction status	MV	AC_FanFlow_xx_xxxxxx	1: None, 2: Vertical, 3: Horizon, 4: All, 5: Spot, 6: Mid, 7: Wide, 8: Swing					
**17	Operation mode limit status	MV	AC_Mode_Limit_xx_xxxxxx	No Limit	Cool Only	Heat Only			
**18	Remote controller limit status	MV	AC_Remocon_Limit_xx_xxxxxx	Enable RC	Disable RC	Conditional RC			
**19	Integrated error code of both indoor unit and outdoor unit	AI	AC_Error_Code_xx_xxxxxx	Refer to list of error code					
*20	SPI setting	BV	AC_SPI_xx_xxxxxx	FALSE	TRUE				
*21	HumanSensor setting	BV	AC_MDS_xx_xxxxxx	FALSE	TRUE				
*22	Discharge cooling set temperature	AV	AC_DisCoolTemp_Set_xx_xxxxxx	°C(°F)					

BACnet Gateway > MIM-B17BUN

Instance Number	Object	Object Type	Object Name	Unit		Status value				
				Inactive	Active					
				Text-1	Text-2	Text-3	Text-4	Text-5		
* 23	Discharge heating set temperature	AV	AC_DisHeatTemp_Set_xx_xxxxxx	°C(°F)						
* 24	Discharge current temperature	AI	AC_DisCurrentTemp_xx_xxxxxx	°C(°F)						
** 25	AC Indoor Notify	NC	AC_Notify_xx_xxxxxx	When the error occurred, send event to list of destination in the recipient_list. (Max : 8)						

Note

- Temperature setting range can be different depending on the model and the common range is as follows:
 - Auto: 18 °C~30 °C
 - Cool: 18 °C~30 °C
 - Heat: 16 °C~30 °C
 - Fan: Temperature cannot be adjusted
 - Dry: 18 °C~30 °C
- (*) Mark is optionally supported. For a fresh duct, (**) mark is supported.

Indoor Unit [Advanced]

Single indoor unit has following point list.

Instance Number	Object	Object Type	Object Name	Unit		Status value				
				Inactive	Active					
				Text-1	Text-2	Text-3	Text-4	Text-5		
1	Indoor Temperature	AI	AC_RoomTemp_xx_xxxxxx	°C						
2	Set temperature	AV	AC_Temp_Set_xx_xxxxxx	°C						
3	Setting lower temperature limit	AV	AC_Cool_LimitTemp_xx_xxxxxx	°C						
4	Setting upper temperature limit	AV	AC_Heat_LimitTemp_xx_xxxxxx	°C						
5	The power value of an indoor unit after the basic date	AI	AC_Baseline_kWh_xx_xxxxxx	kWh						
6	The number of hours usage of an indoor unit after the basic date	AI	AC_Baseline_Minute_xx_xxxxxx	Minute						
7	Power value within period	AI	AC_Period_kWh_xx_xxxxxx	kWh						
8	The number of hours usage of an indoor unit within period	AI	AC_Period_Minute_xx_xxxxxx	Minute						
** 9	Power On/Off	BV	AC_Power_xx_xxxxxx	Off	On					
10	Applying lower temperature limit setting	BV	AC_Cool_Limit_set_xx_xxxxxx	FALSE	TRUE					
11	Applying upper temperature limit setting	BV	AC_Heat_Limit_set_xx_xxxxxx	FALSE	TRUE					
** 12	Filter sign status	BI	AC_FilterSign_xx_xxxxxx	FALSE	TRUE					
** 13	Filter sign reset	BO	AC_FilterSign_Reset_xx_xxxxxx	FALSE	TRUE					
** 14	Operation mode status	MV	AC_Operation_Mode_xx_xxxxxx	Auto	Cool	Heat	Fan	Dry		
* 15	Fan speed status	MV	AC_FanSpeed_xx_xxxxxx	Auto	Low	Mid	High	Turbo		

BACnet Gateway > MIM-B17BUN

Instance Number	Object	Object Type	Object Name	Status value				
				Inactive	Active			
				Text-1	Text-2	Text-3	Text-4	Text-5
* 16	Air flow direction status	MV	AC_FanFlow_xx_xxxxxx	1: None, 2: Vertical, 3: Horizon, 4: All, 5: Spot, 6: Mid, 7: Wide, 8: Swing				
** 17	Operation mode limit status	MV	AC_Mode_Limit_xx_xxxxxx	No Limit	Cool Only	Heat Only		
** 18	Remote controller limit status	MV	AC_Remocon_Limit_xx_xxxxxx	Enable RC	Disable RC	Conditional RC		
** 19	Integrated error code of both indoor unit and outdoor unit	AI	AC_Error_Code_xx_xxxxxx	Refer to list of error code				
* 20	SPI setting	BV	AC_SPI_xx_xxxxxx	FALSE	TRUE			
* 21	HumanSensor setting	BV	AC_MDS_xx_xxxxxx	FALSE	TRUE			
* 22	Discharge cooling set temperature	AV	AC_DisCoolTemp_Set_xx_xxxxxx	°C(°F)				
* 23	Discharge heating set temperature	AV	AC_DisHeatTemp_Set_xx_xxxxxx	°C(°F)				
* 24	Discharge current temperature	AI	AC_DisCurrentTemp_xx_xxxxxx	°C(°F)				
* 25	Wind-Free	BV	AC_WindFree_xx_xxxxxx	FALSE	TRUE			
* 26	MDS air-flow direction	MV	AC_MDS_Opt_Direction_xx_xxxxxx	Indirect	direct			
27	Cooling temperature upper limit	AV	AC_Cool_Upper_LimitTemp_xx_xxxxxx	°C(°F)				
28	Heating temperature lower limit	AV	AC_Heat_Lower_LimitTemp_xx_xxxxxx	°C(°F)				
29	Use of cooling temperature upper limit	BV	AC_Cool_Upper_Limit_set_xx_xxxxxx	FALSE	TRUE			
30	Use of heating temperature lower limit	BV	AC_Heat_Lower_Limit_set_xx_xxxxxx	FALSE	TRUE			
* 31	Automatic Cooling Set Temperature	AV	AC_DualSetPoint_CoolTemp_xx_xxxxxx	°C(°F)				
* 32	Automatic Heating Set Temperature	AV	AC_DualSetPoint_HeatTemp_xx_xxxxxx	°C(°F)				
* 33	Comprehensive air cleanliness	MI	AC_Air_Total_Clean_Level_xx_xxxxxx	1: None, 2: Level 1 (Good), 3: Level 2 (Moderate), 4: Level 3 (Bad), 5: Level 4 (Very bad), 6: Level 5 (Very very bad), 7: Level 6 (Very very very bad)				
* 34	PM10.0 value	AI	AC_Dust_Sensor_PM_10_0	µg/m3				
* 35	PM2.5 value	AI	AC_Dust_Sensor_PM_2_5	µg/m3				
* 36	PM1.0 value	AI	AC_Dust_Sensor_PM_1_0	µg/m3				
** 54	AC Indoor Notify	NC	AC_Notify_xx_xxxxxx	When the error occurred, send event to list of destination in the recipient_list. (Max : 8)				

Of the BACnet points, Reserved points (Instance Numbers 37 to 53) are points for future use.

Note

- Temperature setting range can be different depending on the model and the common range is as follows:
 - Auto: 18 °C~30 °C
 - Cool: 18 °C~30 °C
 - Heat: 16 °C~30 °C
 - Fan: Temperature cannot be adjusted
 - Dry: 18 °C~30 °C
- (*) Mark is optionally supported. For a fresh duct, (**) mark is supported.

BACnet Gateway > MIM-B17BUN

AHU Kit [Basic]

Single AHU unit has following point list.

Instance Number	Object	Object Type	Object Name	Unit	Status value				
				Inactive	Active				
				Text-1	Text-2	Text-3	Text-4	Text-5	
1	Indoor Temperature	AI	AHU_RoomTemp_xx_xxxxxx	°C					
2	Set temperature	AV	AHU_Temp_Set_xx_xxxxxx	°C					
3	Setting lower temperature limit	AV	AHU_Cool_LimitTemp_xx_xxxxxx	°C					
4	Setting upper temperature limit	AV	AHU_Heat_LimitTemp_xx_xxxxxx	°C					
5	The power value of an indoor unit after the basic date	AI	AHU_Baseline_kWh_xx_xxxxxx	kWh					
6	The number of hours usage of an indoor unit after the basic date	AI	AHU_Baseline_Minute_xx_xxxxxx	Minute					
7	Power value within period	AI	AHU_Period_kWh_xx_xxxxxx	kWh					
8	The number of hours usage of an indoor unit within period	AI	AHU_Period_Minute_xx_xxxxxx	Minute					
9	Power On/Off	BV	AHU_Power_xx_xxxxxx	Off	On				
10	Applying lower temperature limit setting	BV	AHU_Cool_Limit_set_xx_xxxxxx	FALSE	TRUE				
11	Applying upper temperature limit setting	BV	AHU_Heat_Limit_set_xx_xxxxxx	FALSE	TRUE				
12	Filter sign status	BI	AHU_FilterSign_xx_xxxxxx	FALSE	TRUE				
13	Filter sign reset	BO	AHU_FilterSign_Reset_xx_xxxxxx	FALSE	TRUE				
14	Operation mode status	MV	AHU_Operation_Mode_xx_xxxxxx	Auto	Cool	Heat	Fan	Dry	
15	Operation mode limit status	MV	AHU_Mode_Limit_xx_xxxxxx	No Limit	Cool Only	Heat Only			
16	Remote controller limit status	MV	AHU_Remocon_Limit_xx_xxxxxx	Enable RC	Disable RC	Conditional RC			
17	Integrated error code of both indoor unit and outdoor unit	AI	AHU_Error_Code_xx_xxxxxx	Refer to list of error code					
*18	Discharge cooling set temperature	AV	AHU_DisCoolSetTemp_xx_xxxxxx	°C					
*19	Discharge heating set temperature	AV	AHU_DisHeatSetTemp_xx_xxxxxx	°C					
*20	Discharge current temperature	AI	AHU_Dis_CurrentTemp_xx_xxxxxx	°C					
*21	Humidification setting	BV	AHU_Humidification_xx_xxxxxx	Off	On				
*22	Outdoor air intake setting	BV	AHU_OAIntake_xx_xxxxxx	Off	On				
*23	Outdoor cooling setting	BV	AHU_OutdoorCool_xx_xxxxxx	Off	On				
*24	Fan speed status	MV	AHU_FanSpeed_xx_xxxxxx	Low	Mid	High			
*25	Set humidity status	MV	AHU_SetHumidity_xx_xxxxxx	Low	Mid	High			
*26	Current humidity status	MI	AHU_CurrentHumidity_xx_xxxxxx	Low	Mid	High			
27	AHU Notify	NC	AHU_Notify_xx_xxxxxx	When the error occurred, send event to list of destination in the recipient_list. (Max : 8)					

Note

- (*) Mark is optionally supported.

BACnet Gateway > MIM-B17BUN

■ AHU Kit [Advanced]

Single AHU unit has following point list.

Instance Number	Object	Object Type	Object Name	Unit	Status value				
				Inactive	Active				
				Text-1	Text-2	Text-3	Text-4	Text-5	
1	Indoor Temperature	AI	AHU_RoomTemp_xx_xxxxxx	°C					
2	Set temperature	AV	AHU_Temp_Set_xx_xxxxxx	°C					
3	Setting lower temperature limit	AV	AHU_Cool_LimitTemp_xx_xxxxxx	°C					
4	Setting upper temperature limit	AV	AHU_Heat_LimitTemp_xx_xxxxxx	°C					
5	The power value of an indoor unit after the basic date	AI	AHU_Baseline_kWh_xx_xxxxxx	kWh					
6	The number of hours usage of an indoor unit after the basic date	AI	AHU_Baseline_Minute_xx_xxxxxx	Minute					
7	Power value within period	AI	AHU_Period_kWh_xx_xxxxxx	kWh					
8	The number of hours usage of an indoor unit within period	AI	AHU_Period_Minute_xx_xxxxxx	Minute					
9	Power On/Off	BV	AHU_Power_xx_xxxxxx	Off	On				
10	Applying lower temperature limit setting	BV	AHU_Cool_Limit_set_xx_xxxxxx	FALSE	TRUE				
11	Applying upper temperature limit setting	BV	AHU_Heat_Limit_set_xx_xxxxxx	FALSE	TRUE				
12	Filter sign status	BI	AHU_FilterSign_xx_xxxxxx	FALSE	TRUE				
13	Filter sign reset	BO	AHU_FilterSign_Reset_xx_xxxxxx	FALSE	TRUE				
14	Operation mode status	MV	AHU_Operation_Mode_xx_xxxxxx	Auto	Cool	Heat	Fan	Dry	
15	Operation mode limit status	MV	AHU_Mode_Limit_xx_xxxxxx	No Limit	Cool Only	Heat Only			
16	Remote controller limit status	MV	AHU_Remocon_Limit_xx_xxxxxx	Enable RC	Disable RC	Conditional RC			
17	Integrated error code of both indoor unit and outdoor unit	AI	AHU_Error_Code_xx_xxxxxx	Refer to list of error code					
*18	Discharge cooling set temperature	AV	AHU_DisCoolSetTemp_xx_xxxxxx	°C					
*19	Discharge heating set temperature	AV	AHU_DisHeatSetTemp_xx_xxxxxx	°C					
*20	Discharge current temperature	AI	AHU_Dis_CurrentTemp_xx_xxxxxx	°C					
*21	Humidification setting	BV	AHU_Humidification_xx_xxxxxx	Off	On				
*22	Outdoor air intake setting	BV	AHU_OAIntake_xx_xxxxxx	Off	On				
*23	Outdoor cooling setting	BV	AHU_OutdoorCool_xx_xxxxxx	Off	On				
*24	Fan speed status	MV	AHU_FanSpeed_xx_xxxxxx	Low	Mid	High			
*25	Set humidity status	MV	AHU_SetHumidity_xx_xxxxxx	Low	Mid	High			
*26	Current humidity status	MI	AHU_CurrentHumidity_xx_xxxxxx	Low	Mid	High			
27	Cooling temperature upper limit	AV	AHU_Cool_Upper_LimitTemp_xx_xxxxx	°C(°F)					
28	Heating temperature lower limit	AV	AHU_Heat_Lower_LimitTemp_xx_xxx xx	°C(°F)					
29	Use of cooling temperature upper limit	BV	AHU_Cool_Upper_Limit_set_xx_xxxxx	FALSE	TRUE				

BACnet Gateway > MIM-B17BUN

Instance Number	Object	Object Type	Object Name	Unit		Status value				
				Inactive	Active					
				Text-1	Text-2	Text-3	Text-4	Text-5		
30	Use of heating temperature lower limit	BV	AHU_Heat_Lower_Limit_set_xx_xxxxx	FALSE	TRUE					
*31	Automatic Cooling Set Temperature	AV	AHU_DualSetPoint_CoolTemp_xx_xxxxx	°C(°F)						
*32	Automatic Heating Set Temperature	AV	AHU_DualSetPoint_HeatTemp_xx_xxxxx	°C(°F)						
33	AHU Notify	NC	AHU_Notify_xx_xxxxx	When the error occurred, send event to list of destination in the recipient_list. (Max : 8)						

Note

- (*) Mark is optionally supported.

EHS [Basic]

Single EHS Unit has following point list.

Instance Number	Object	Object Type	Object Name	Unit		Status value			
				Inactive	Active				
				Text-1	Text-2	Text-3	Text-4		
1	Room temperature	AI	EHS_RoomTemp_xx_xxxxx	°C					
2	Set temperature	AV	EHS_Temp_Set_xx_xxxxx	°C	Use when displayed temperature type is set to 'Room'.				
3	Set temperature of water out	AV	EHS_WaterOutTemp_Set_xx_xxxxx	°C	Use when displayed temperature type is set to 'WaterOut'.				
4	Set temperature of hot water	AV	EHS_HotWaterTemp_Set_xx_xxxxx	°C					
5	Setting lower temperature limit	AV	EHS_Cool_LimitTemp_xx_xxxxx	°C	Use when displayed temperature type is set to 'Room'.				
6	Setting upper temperature limit	AV	EHS_Heat_LimitTemp_xx_xxxxx	°C	Use when displayed temperature type is set to 'Room'.				
7	Lower temperature limit for water out	AV	EHS_WOCoolLimitTemp_xx_xxxxx	°C					
8	Upper temperature limit for water out	AV	EHS_WOHeatLimitTemp_xx_xxxxx	°C					
9	Upper temperature limit for hot water	AV	EHS_WHeatLimitTemp_xx_xxxxx	°C					
10	The power value after the basic date	AI	EHS_Baseline_kWh_xx_xxxxx	kWh					
11	The number of hours usage of an indoor unit after the basic date	AI	EHS_Baseline_Minute_xx_xxxxx	Minute					
12	Power value within period	AI	EHS_Period_kWh_xx_xxxxx	kWh					
13	The number of hours usage of an indoor unit within period	AI	EHS_Period_Minute_xx_xxxxx	Minute					
14	Current temperature of water out	AI	EHS_WOCurrentTemp_xx_xxxxx	°C					
15	Current temperature of hot water	AI	EHS_HotWaterTemp_xx_xxxxx	°C					
16	Displayed temperature type	BI	EHS_ControlTempType_xx_xxxxx	Room	WaterOut				

Instance Number	Object	Object Type	Object Name	Unit		Status value	
				Inactive	Active		
				Text-1	Text-2	Text-3	Text-4
17	Thermostat usage	BI	EHS_Thermostat_xx_xxxxxx	FALSE	TRUE		
18	Outing	BI	EHS_GoOut_xx_xxxxxx	Off	On		
19	Power On/Off	BV	EHS_Power_xx_xxxxxx	Off	On		
20	Setting lower temperature limit	BV	EHS_Cool_LimitTemp_Set_xx_xxxxxx	FALSE	TRUE	Use when displayed temperature type is set to 'Room'.	
21	Setting upper temperature limit	BV	EHS_Heat_LimitTemp_Set_xx_xxxxxx	FALSE	TRUE	Use when displayed temperature type is set to 'Room'.	
22	Apply lower temperature limit for water out	BV	EHS_WOCoolLimitFlag_xx_xxxxxx	FALSE	TRUE	Use when displayed temperature type is set to 'WaterOut'.	
23	Apply upper temperature limit for water out	BV	EHS_WOHeatLimitFlag_xx_xxxxxx	FALSE	TRUE	Use when displayed temperature type is set to 'WaterOut'.	
24	Apply upper temperature limit for hot water	BV	EHS_WTHeatLimitFlag_xx_xxxxxx	FALSE	TRUE		
25	On/Off status of hot water mode	BV	EHS_HotWater_Power_xx_xxxxxx	Off	On		
26	Status of quiet operation	BV	EHS_Sleep_xx_xxxxxx	Off	On		
27	Operation mode status	MV	EHS_Operation_Mode_xx_xxxxxx	Auto	Cool	Heat	
28	Operation mode limit status	MV	EHS_Mode_Limit_xx_xxxxxx	No Limit	Cool Only	Heat Only	
29	Remote controller limit status	MV	EHS_Remocon_Limit_xx_xxxxxx	Enable RC	Disable RC	Conditional RC	
30	Status of hot water operation mode	MV	EHS_HotWater_Mode_xx_xxxxxx	* Force	Eco	Standard	Power
31	Integrated error code of both indoor unit and outdoor unit	AI	EHS_Error_Code_xx_xxxxxx				
32	EHS notify	NC	EHS_Notify_xx_xxxxxx	When the error occurred, send event to list of destination in the recipient_list. (Max : 8)			

Note

- Force hot water mode (* marked) will be supported later. It is the point list of Hydro Unit and Hydro Unit HT.

BACnet Gateway > MIM-B17BUN

EHS [Advanced]

Single EHS Unit has following point list.

Instance Number	Object	Object Type	Object Name	Unit		Status value	
				Inactive	Active	Text-3	Text-4
				Text-1	Text-2		
1	Room temperature	AI	EHS_RoomTemp_xx_xxxxx	°C			
2	Set temperature	AV	EHS_Temp_Set_xx_xxxxx	°C	Use when displayed temperature type is set to 'Room'.		
3	Set temperature of water out	AV	EHS_WaterOutTemp_Set_xx_xxxxx	°C	Use when displayed temperature type is set to 'WaterOut'.		
4	Set temperature of hot water	AV	EHS_HotWaterTemp_Set_xx_xxxxx	°C			
5	Setting lower temperature limit	AV	EHS_Cool_LimitTemp_xx_xxxxx	°C	Use when displayed temperature type is set to 'Room'.		
6	Setting upper temperature limit	AV	EHS_Heat_LimitTemp_xx_xxxxx	°C	Use when displayed temperature type is set to 'Room'.		
7	Lower temperature limit for water out	AV	EHS_WOCoolLimitTemp_xx_xxxxx	°C			
8	Upper temperature limit for water out	AV	EHS_WOHeatLimitTemp_xx_xxxxx	°C			
9	Upper temperature limit for hot water	AV	EHS_WHeatLimitTemp_xx_xxxxx	°C			
10	The power value after the basic date	AI	EHS_Baseline_kWh_xx_xxxxx	kWh			
11	The number of hours usage of an indoor unit after the basic date	AI	EHS_Baseline_Minute_xx_xxxxx	Minute			
12	Power value within period	AI	EHS_Period_kWh_xx_xxxxx	kWh			
13	The number of hours usage of an indoor unit within period	AI	EHS_Period_Minute_xx_xxxxx	Minute			
14	Current temperature of water out	AI	EHS_WOCurrentTemp_xx_xxxxx	°C			
15	Current temperature of hot water	AI	EHS_HotWaterTemp_xx_xxxxx	°C			
16	Displayed temperature type	BI	EHS_ControlTempType_xx_xxxxx	Room	WaterOut		
17	Thermostat usage	BI	EHS_Thermostat_xx_xxxxx	FALSE	TRUE		
18	Outing	BI	EHS_GoOut_xx_xxxxx	Off	On		
19	Power On/Off	BV	EHS_Power_xx_xxxxx	Off	On		
20	Setting lower temperature limit	BV	EHS_Cool_LimitTemp_Set_xx_xxxxx	FALSE	TRUE	Use when displayed temperature type is set to 'Room'.	
21	Setting upper temperature limit	BV	EHS_Heat_LimitTemp_Set_xx_xxxxx	FALSE	TRUE	Use when displayed temperature type is set to 'Room'.	
22	Apply lower temperature limit for water out	BV	EHS_WOCoolLimitFlag_xx_xxxxx	FALSE	TRUE	Use when displayed temperature type is set to 'WaterOut'.	

BACnet Gateway > MIM-B17BUN

Instance Number	Object	Object Type	Object Name	Unit		Status value	
				Inactive	Active	Text-3	Text-4
				Text-1	Text-2		
23	Apply upper temperature limit for water out	BV	EHS_WOHeatLimitFlag_xx_xxxxxx	FALSE	TRUE	Use when displayed temperature type is set to 'WaterOut'.	
24	Apply upper temperature limit for hot water	BV	EHS_WTHeatLimitFlag_xx_xxxxxx	FALSE	TRUE		
25	On/Off status of hot water mode	BV	EHS_HotWater_Power_xx_xxxxxx	Off	On		
26	Status of quiet operation	BV	EHS_Sleep_xx_xxxxxx	Off	On		
27	Operation mode status	MV	EHS_Operation_Mode_xx_xxxxxx	Auto	Cool	Heat	
28	Operation mode limit status	MV	EHS_Mode_Limit_xx_xxxxxx	No Limit	Cool Only	Heat Only	
29	Remote controller limit status	MV	EHS_Remocon_Limit_xx_xxxxxx	Enable RC	Disable RC	Conditional RC	
30	Status of hot water operation mode	MV	EHS_HotWater_Mode_xx_xxxxxx	* Force	Eco	Standard	Power
31	Integrated error code of both indoor unit and outdoor unit	AI	EHS_Error_Code_xx_xxxxxx				
32	Cooling temperature upper limit	AV	EHS_Cool_Upper_LimitTemp_xx_xxxxxx	°C(°F)	Used when the room temperature is used as the temperature display reference		
33	Heating temperature lower limit	AV	EHS_Heat_Lower_LimitTemp_xx_xxxxxx	°C(°F)	Used when the room temperature is used as the temperature display reference		
34	Cooling temperature upper limit, based on water out temperature	AV	EHS_WO_Cool_Upper_LimitTemp_xx_xxxxxx	°C(°F)	Used when the water out temperature is used as the temperature display reference		
35	Heating temperature lower limit, based on water out temperature	AV	EHS_WO_Heat_Lower_LimitTemp_xx_xxxxxx	°C(°F)	Used when the water out temperature is used as the temperature display reference		
36	Hot water temperature lower limit	AV	EHS_WT_Heat_Lower_LimitTemp_xx_xxxxxx	°C(°F)			
37	Use of cooling temperature upper limit	BV	EHS_Cool_Upper_Limit_set_xx_xxxxxx	FALSE	TRUE	Used when the room temperature is used as the temperature display reference	
38	Use of heating temperature lower limit	BV	EHS_Heat_Lower_Limit_set_xx_xxxxxx	FALSE	TRUE	Used when the room temperature is used as the temperature display reference	
39	Use of cooling temperature upper limit, based on water out temperature	BV	EHS_WO_Cool_Upper_LimitFlag_xx_xxxxxx	FALSE	TRUE	Used when the water out temperature is used as the temperature display reference	
40	Use of heating temperature lower limit, based on water out temperature	BV	EHS_WO_Heat_Lower_LimitFlag_xx_xxxxxx	FALSE	TRUE	Used when the water out temperature is used as the temperature display reference	

BACnet Gateway > MIM-B17BUN

Instance Number	Object	Object Type	Object Name	Unit		Status value	
				Inactive	Active		
				Text-1	Text-2	Text-3	Text-4
41	Use of hot water temperature lower limit	BV	EHS_WT_Heat_Lower_LimitFlag_xx_xxxxx	FALSE	TRUE		
42	EHS notify	NC	EHS_Notify_xx_xxxxx	When the error occurred, send event to list of destination in the recipient_list. (Max : 8)			

Note

- Force hot water mode (* marked) will be supported later. It is the point list of Hydro Unit and Hydro Unit HT.

ERV, ERV Plus [Basic, Advanced]

Single ERV or ERV Plus unit has following point list.

Instance Number	Object	Object Type	Object Name	Unit		Status value		
				Inactive	Active			
				Text-1	Text-2	Text-3	Text-4	Text-5
1	Power On/Off operation	BV	ERV_Power_xx_xxxxx	Off	On			
2	Filter sign status	BI	ERV_FilterSign_xx_xxxxx	FALSE	TRUE			
3	Filter sign reset	BO	ERV_FilterSign_Reset_xx_xxxxx	FALSE	TRUE			
4	Operation mode status	MV	ERV_Operation_Mode_xx_xxxxx	Auto	HeatEx	Bypass	Sleep	
5	Fan speed status	MV	ERV_FanSpeed_xx_xxxxx	Low	High	Turbo		
6	Remote controller limit status	MV	ERV_Remocon_Limit_xx_xxxxx	Enable RC	Disable RC	Conditional RC		
7	Integrated error code of ERV unit	AI	ERV_Error_Code_xx_xxxxx					
*8	The power value of an ERV Plus unit after the basic date	AI	ERV_Plus_Baseline_kWh_xx_xxxxx	kWh				
*9	The number of hours usage of an ERV Plus unit after the basic date	AI	ERV_Plus_Baseline_Minute_xx_xxxxx	Minute				
*10	Power value within period	AI	ERV_Plus_Period_kWh_xx_xxxxx	kWh				
*11	The number of hours usage of an ERV Plus unit within period	AI	ERV_Plus_Period_Minute_xx_xxxxx	Minute				
*12	ERV Plus operation mode status	MV	ERV_Plus_Operation_Mode_xx_xxxxx	Auto	Cool	Heat	Off	
*13	ERV Plus operation mode limit status	MV	ERV_Plus_Mode_Limit_xx_xxxxx	No Limit	Cool Only	Heat Only		
14	ERV Notify	NC	ERV_Notify_xx_xxxxx	When the error occurred, send event to list of destination in the recipient_list. (Max : 8)				

Note

- (*) Mark is optionally supported.

BACnet Gateway > MIM-B17BUN

■ DVM CHILLER [Basic, Advanced]

Single DVM CHILLER Unit has following point list.

Instance Number	Object	Object Type	Object Name	Status value				
				Inactive	Active			
				Text-1	Text-2	Text-3	Text-4	Text-5
1	Chilled Water Temperature	AI	MC_WaterTemp_xx_xxxxxx	°C/F				
2	Set temperature	AV	MC_WaterTemp_Set_xx_xxxxxx	°C/F				
3	Demand limit setting	AV	MC_Demand_Set_xx_xxxxxx	%				
4	The number of hours usage of an indoor unit after the basic date	AI	MC_Baseline_Minute_xx_xxxxxx	Minute				
5	The number of hours usage of an indoor unit within peirod	AI	MC_Period_Minute_xx_xxxxxx	Minute				
6	Power On/Off operation	BV	MC_Power_xx_xxxxxx	Off	On			
7	Water Law	BO	MC_Water_Law_xx_xxxxxx	FALSE	TRUE			
8	Quiet	BV	MC_Quiet_xx_xxxxxx	Off	On			
9	Forced Fan	BV	MC_Forced_Fan_xx_xxxxxx	Off	On			
10	Operation mode status	MV	MC_Operation_Mode_xx_xxxxxx	Cool	Heat	Cool Storage	Hot Water	
11	Remote controller limit status	MV	MC_Remocon_Limit_xx_xxxxxx	Enable RC	Disable RC	Conditional RC		
12	Integrated error code	AI	MC_Error_Code_xx_xxxxxx					
13	DVM CHILLER Notify	NC	MC_Notify_xx_xxxxxx	When the error occurred, send event to list of destination in the recipient_list. (Max : 8)				

BACnet Device Object does not support master function of DVM CHILLER.

Demand control setting range is as follows:

50,55,60,65,70,75,80,85,90,95,100(%)

■ SIM/PIM [Basic, Advanced]

Single SIM/PIM has following point list.

Instance Number	Object	Object Type	Object Name	Status value
1	SIM/PIM error code	AI	SIM_Error_Code_xx_xx	Refer to list of error code
2	SIM/PIM Notify	NC	SIM_Notify_xx_xx	When the error occurred, send event to list of destination in the recipient_list. (Max : 8)

■ Centralized Controller (OnOff Controller) [Basic, Advanced]

Single Centralized Controller (OnOff Controller) has following point list.

Instance Number	Object	Object Type	Object Name	Status value
1	Centralized Controller (OnOff Controller) error code	AI	Central_Error_Code_xx_xx	Refer to the list of the integrated error code
2	Centralized Controller (OnOff Controller) notify	NC	Central_Notify_xx_xx	When the error occurred, send event to list of destination in the recipient_list. (Max : 8)

BACnet Gateway > MIM-B17BUN

Interface Module (Outdoor Unit) [Basic]

Single Interface Module (Outdoor Unit) has following point list.

Instance Number	Object	Object Type	Object Name	Unit	Status value				
				Inactive	Active				
				Text-1	Text-2	Text-3	Text-4	Text-5	
1	Outside temperature	AI	ODU_Outside_Temp_xx_xxxx	°C					
* 2	Cool capacity compensation	AV	ODU_Cool_Compensation_xx_xxxx	0 : 5~7°C / 1 : 7~9°C / 2 : 9~11°C / 3 : 10~12°C / 4 : 11~13°C / 5 : 12~14°C / 6 : 13~15°C / 14 : Auto control (from ODU)					
* 3	Heat capacity compensation	AV	ODU_Heat_Compensation_xx_xxxx	0 : 25 kg/cm ² / 1 : 26 kg/cm ² / 2 : 27 kg/cm ² / 3 : 28 kg/cm ² / 4 : 29 kg/cm ² / 5 : 30 kg/cm ² / 6 : 31 kg/cm ² / 7 : 32 kg/cm ² / 8 : 33 kg/cm ² / 14 : Auto control (from ODU)					
4	Compressor status	BI	ODU_Comp_Status_xx_xxxx	FALSE	TRUE				
5	Interface Module (Outdoor Unit) error code	AI	Repeater_Error_Code_xx_xxxx	Refer to the list of the integrated error code					
6	Interface Module (Outdoor Unit) notify	NC	IM_Notify_xx_xxxx	When the error occurred, send event to list of destination in the recipient_list. (Max : 8)					

Note

- (*) Mark is optionally supported.

Interface Module (Outdoor Unit) [Advanced]

Single Interface Module (Outdoor Unit) has following point list.

Instance Number	Object	Object Type	Object Name	Unit	Status value				
				Inactive	Active				
				Text-1	Text-2	Text-3	Text-4	Text-5	
1	Outside temperature	AI	ODU_Outside_Temp_xx_xxxx	°C					
* 2	Cool capacity compensation	AV	ODU_Cool_Compensation_xx_xxxx	0 : 5~7°C / 1 : 7~9°C / 2 : 9~11°C / 3 : 10~12°C / 4 : 11~13°C / 5 : 12~14°C / 6 : 13~15°C / 14 : Auto control (from ODU)					
* 3	Heat capacity compensation	AV	ODU_Heat_Compensation_xx_xxxx	0 : 25 kg/cm ² / 1 : 26 kg/cm ² / 2 : 27 kg/cm ² / 3 : 28 kg/cm ² / 4 : 29 kg/cm ² / 5 : 30 kg/cm ² / 6 : 31 kg/cm ² / 7 : 32 kg/cm ² / 8 : 33 kg/cm ² / 14 : Auto control (from ODU)					
4	Compressor status	BI	ODU_Comp_Status_xx_xxxx	FALSE	TRUE				
5	Interface Module (Outdoor Unit) error code	AI	Repeater_Error_Code_xx_xxxx	Refer to the list of the integrated error code					

BACnet Gateway > MIM-B17BUN

Instance Number	Object	Object Type	Object Name	Unit		Status value		
				Inactive	Active			
				Text-1	Text-2	Text-3	Text-4	Text-5
*6	Water temperature	AI	ODU_Water_Temp_xx_xxxxx	°C(°F)		Only valid for the DVM water outdoor unit		
*7	Hot gas charging valve	BI	ODU_HotGas_Charging_Valve_xx_xxxxx	FALSE	TRUE	Only valid for the DVM water outdoor unit		
8	Interface Module (Outdoor Unit) notify	NC	IM_Notify_xx_xxxx	When the error occurred, send event to list of destination in the recipient_list. (Max : 8)				

Note

- (*) Mark is optionally supported.

BACnet Gateway [Basic, Advanced]

BACnet Gateway has following point list.

Instance Number	Control and Monitoring	Object Type	Object Name	Status Value
1	All device OFF	BO	ALL_OFF_xx	Inactive : All devices Off
2	DMS2.5 Status	AI	DMS2.5_Status_xx	0: Normal, 8: Emergency stop, 105 : Tracking in progress, 108 : Tracking failed 109 : DMS2.5↔BACnet Communication failed
3	BACnet error code	AI	BACnetApp_Error_Code_xx	BACnet error code
4	Gateway Notify	NC	GW_Notify_xx	When the error occurred, send event to list of destination in the recipient_list. (Max : 8)

BACnet Gateway › MIM-B17BUN

DDC [Basic, Advanced]

DDC has following point list.

Instance Number	Object	Object Type	Object Name	Unit		Status value				
				Inactive	Active					
				Text-1	Text-2	Text-3	Text-4	Text-5		
1	Digital Input 1	BI	DI_01_xx_xx (BACnet Gateway Reserved)	Off	On					
2	Digital Input 2	BI	DI_02_xx_xx (BACnet Gateway Reserved)	Off	On					
3	Digital Input 3	BI	DI_03_xx_xx	Off	On					
4	Digital Input 4	BI	DI_04_xx_xx	Off	On					
5	Digital Input 5	BI	DI_05_xx_xx	Off	On					
6	Digital Input 6	BI	DI_06_xx_xx	Off	On					
7	Digital Input 7	BI	DI_07_xx_xx	Off	On					
8	Digital Input 8	BI	DI_08_xx_xx	Off	On					
9	Digital Input 9	BI	DI_09_xx_xx	Off	On					
10	Digital Input 10	BI	DI_10_xx_xx	Off	On					
11	Digital Output 1	BO	DO_01_xx_xx (BACnet Gateway Reserved)	Off	On					
12	Digital Output 2	BO	DO_02_xx_xx (BACnet Gateway Reserved)	Off	On					
13	Digital Output 3	BO	DO_03_xx_xx	Off	On					
14	Digital Output 4	BO	DO_04_xx_xx	Off	On					
15	Digital Output 5	BO	DO_05_xx_xx	Off	On					
16	Digital Output 6	BO	DO_06_xx_xx	Off	On					
17	Digital Output 7	BO	DO_07_xx_xx	Off	On					
18	Digital Output 8	BO	DO_08_xx_xx	Off	On					

⚠ Caution

- If communication error occurs on devices such as SIM/PIM/Centralized Controller (OnOff Controller)/Interface Module (Outdoor Unit) etc, other functions such as power distribution may also create a problem. You must have BMS system to check the errors and you must take action immediately.

Checking BACnet communication through Wireshark

Who-is (I-Am)

- After device instance numbers have been automatically assigned, Who-is command which is requested in the Wireshark will be replied by i-am from the devices.

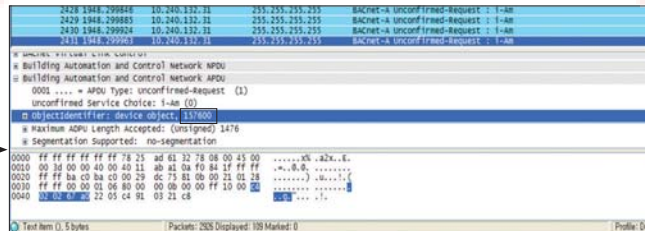
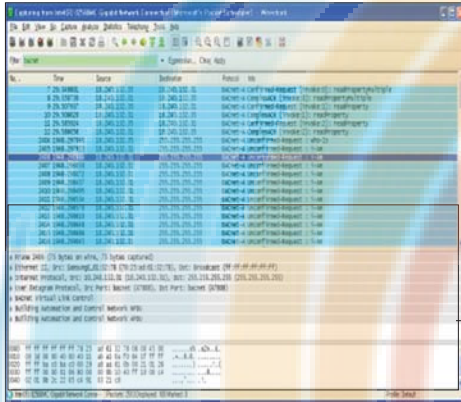

ReadPropertyMultiple

- Request all status datas.
- Device description, BACnet network number device node ID, status, BACnet MAC address version, Max APDU length accepted, APDU retries, timeout, supported services, supported object types and so on.

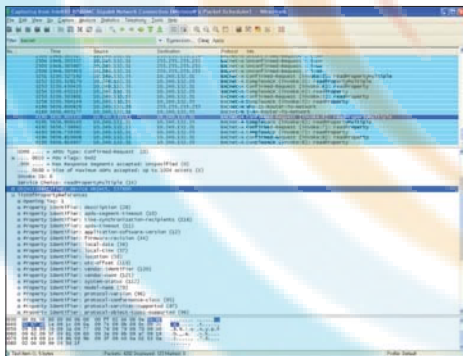

ReadPropertyMultiple Request

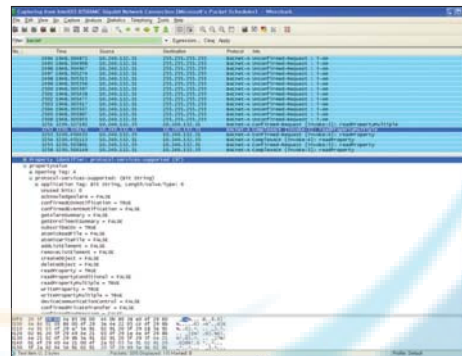

ReadPropertyMultiple Response

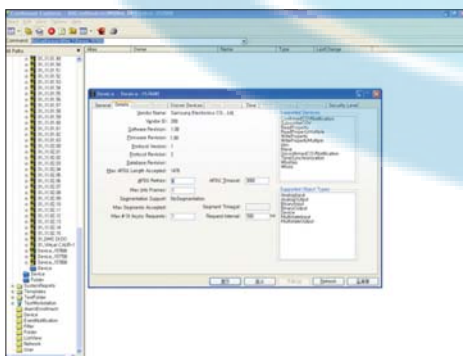

Continuum CyberStation

ReadPropertyMultiple

- Object_MultiStateInput

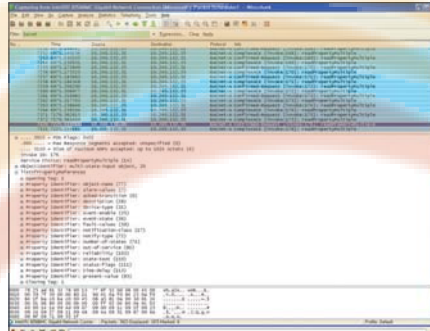
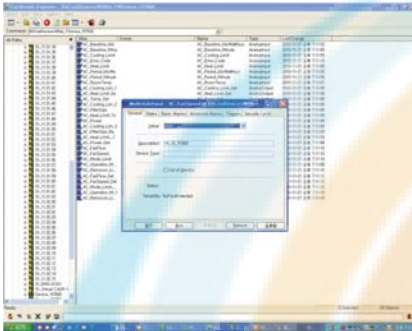

Request

```

Property Identifier: state-text (110)
propertyvalue
  Opening Tag: 4
  state-text: 'Auto'
  state-text: 'Low'
  state-text: 'Mid'
  state-text: 'High'
  state-text: 'No State'
  Closing Tag: 4
Property Identifier: status-flags (111)
propertyvalue
  Opening Tag: 4
  status-flags: (bit string)
  Closing Tag: 4
Property Identifier: time-delay (113)
propertyAccessError
  Opening Tag: 5
  error Class: property
  error Code: unknown-property
  Closing Tag: 5
Property Identifier: present-value (85)
propertyvalue
  Opening Tag: 4
  present-value: (unsigned) 1
  Closing Tag: 4
Closing Tag: 1
    
```

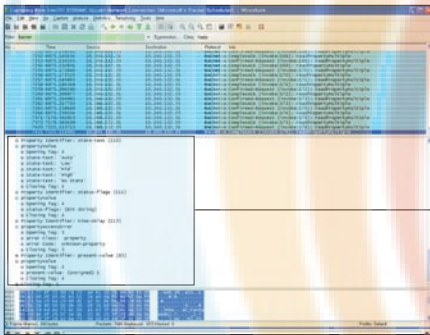

- WriteProperty

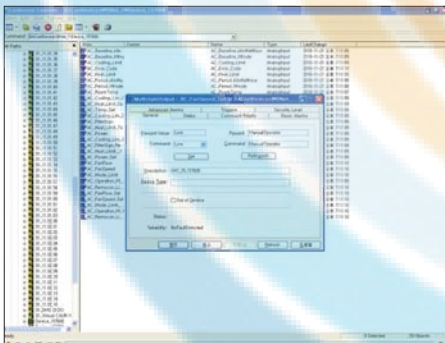

Change the FanSpeed from Auto to Low

```

BACnet-A Confirmed-Request [invoke:179]: writeProperty
BACnet-A SimpleACK [invoke:179]: writeProperty
BACnet-A Confirmed-Request [invoke:180]: readPropertyMultiple
BACnet-A ComplexACK [invoke:180]: readPropertyMultiple
    
```

1. Request - WriteProperty (FanSpeed 'Auto' → 'Low')
2. Response - SimpleACK
3. Request - ReadPropertyMultiple (FanSpeed)
4. Response - ReadPropertyMultiple (FanSpeed 'Low')

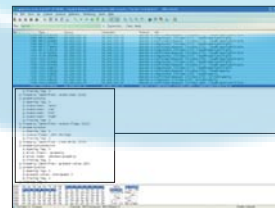
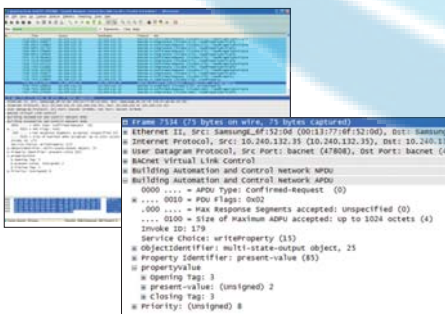

```

Property Identifier: state-text (110)
propertyvalue
  Opening Tag: 4
  state-text: 'Auto'
  state-text: 'Low'
  state-text: 'Mid'
  state-text: 'High'
  Closing Tag: 4
Property Identifier: status-flags (111)
propertyvalue
  Opening Tag: 4
  status-flags: (bit string)
  Closing Tag: 4
Property Identifier: time-delay (113)
propertyAccessError
  Opening Tag: 5
  error Class: property
  error Code: unknown-property
  Closing Tag: 5
Property Identifier: present-value (85)
propertyvalue
  Opening Tag: 4
  present-value: (unsigned) 2
  Closing Tag: 4
Closing Tag: 1
    
```

WriteProperty

ReadPropertyMultiple

Subscribe COV

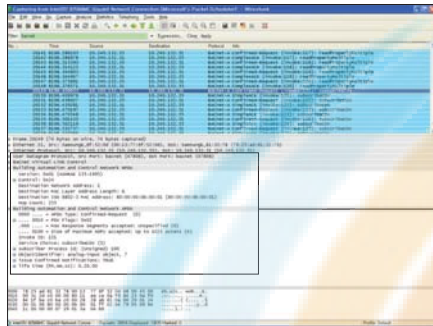

Request

```
User Datagram Protocol, Src Port: bacnet (47808), Dst Port: bacnet (47808)
BACnet Virtual Link Control
Building Automation and Control Network NPDU
  Version: 0x01 (ASHRAE 135-1995)
  Control: 0x24
  Destination Network Address: 1
  Destination MAC Layer Address Length: 6
  Destination ISO 8802-3 MAC Address: 80:00:00:0b:00:01 (80:00:00:0b:00:01)
  Hop Count: 255
Building Automation and Control Network APDU
  0000 .... = APDU Type: Confirmed-Request (0)
  .... 0010 = PDU Flags: 0x02
  .000 .... = Max Response Segments accepted: Unspecified (0)
  .... 0100 = Size of Maximum APDU accepted: up to 1024 octets (4)
  Invoke ID: 121
  Service choice: subscribecov (5)
  subscriber Process ID: (Unsigned) 100
  ObjectIdentifier: analog-input object, 7
  issue Confirmed Notifications: TRUE
  life time (hh.mm.ss): 0.20.00
```

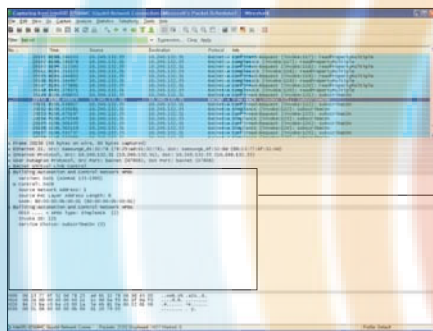

Response

```
User Datagram Protocol, Src Port: bacnet (47808)
BACnet Virtual Link Control
Building Automation and Control Network NPDU
  Version: 0x01 (ASHRAE 135-1995)
  Control: 0x08
  Source Network Address: 1
  Source MAC Layer Address Length: 6
  SADR: 80:00:00:0b:00:01 (80:00:00:0b:00:01)
Building Automation and Control Network APDU
  0010 .... = APDU Type: SimpleACK (2)
  Invoke ID: 121
  Service Choice: subscribecov (5)
```

COV Notification

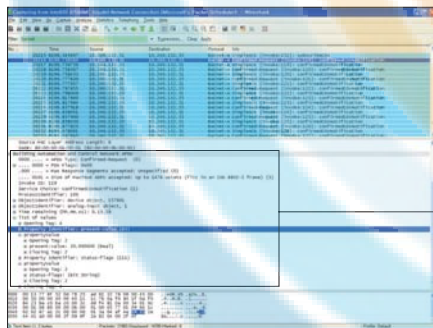

Notification

```
Building Automation and Control Network APDU
  0000 .... = APDU Type: Confirmed-Request (0)
  .... 0000 = PDU Flags: 0x00
  .000 .... = Max Response Segments accepted: Unspecified (0)
  .... 0101 = Size of Maximum APDU accepted: up to 1476 octets (fits in an ISO 8802-3 frame) (5)
  Invoke ID: 119
  Service choice: confirmedCOVNotification (1)
  ProcessIdentifier: 100
  ObjectIdentifier: device object, 157601
  ObjectIdentifier: analog-input object, 1
  Time remaining (hh.mm.ss): 0.19.59
  List of values:
  Opening Tag: 4
  Property Identifier: present-value (65)
  propertyvalue
  Opening Tag: 2
  present-value: 20.000000 (Real)
  Closing Tag: 2
  Property Identifier: status-flags (111)
  propertyvalue
  Opening Tag: 2
  status-flags: (fmt string)
  Closing Tag: 2
  Closing Tag: 4
```

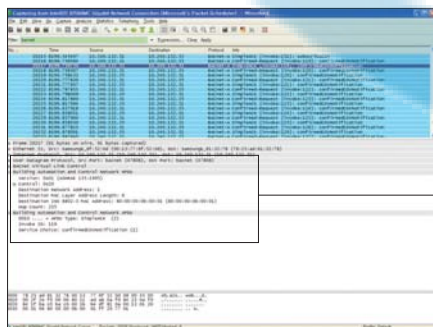

Response

```
BACnet Virtual Link Control
Building Automation and Control Network NPDU
  Version: 0x01 (ASHRAE 135-1995)
  Control: 0x20
  Destination Network Address: 1
  Destination MAC Layer Address Length: 6
  Destination ISO 8802-3 MAC Address: 80:00:00:0b:00:01 (80:00:00:0b:00:01)
  Hop Count: 255
Building Automation and Control Network APDU
  0010 .... = APDU Type: SimpleACK (2)
  Invoke ID: 119
  Service choice: confirmedCOVNotification (1)
```

Standard Object Types Supported

Object Type	Supported	Dynamically Creatable	Dynamically Deletable	Writeable Properties
Analog Input	<input checked="" type="checkbox"/>	<input type="checkbox"/>	<input type="checkbox"/>	
Analog Output	<input type="checkbox"/>	<input type="checkbox"/>	<input type="checkbox"/>	
Analog Value	<input checked="" type="checkbox"/>	<input type="checkbox"/>	<input type="checkbox"/>	Present value
Binary Input	<input checked="" type="checkbox"/>	<input type="checkbox"/>	<input type="checkbox"/>	
Binary Output	<input checked="" type="checkbox"/>	<input type="checkbox"/>	<input type="checkbox"/>	Present value
Binary Value	<input checked="" type="checkbox"/>	<input type="checkbox"/>	<input type="checkbox"/>	Present value
Calendar	<input type="checkbox"/>	<input type="checkbox"/>	<input type="checkbox"/>	
Command	<input type="checkbox"/>	<input type="checkbox"/>	<input type="checkbox"/>	
Device	Yes	n/a	n/a	n/a
Event Enrollment	<input type="checkbox"/>	<input type="checkbox"/>	<input type="checkbox"/>	
File	<input type="checkbox"/>	<input type="checkbox"/>	<input type="checkbox"/>	
Group	<input type="checkbox"/>	<input type="checkbox"/>	<input type="checkbox"/>	
Loop	<input type="checkbox"/>	<input type="checkbox"/>	<input type="checkbox"/>	
Multi-state Input	<input checked="" type="checkbox"/>	<input type="checkbox"/>	<input type="checkbox"/>	Present value
Multi-state Output	<input type="checkbox"/>	<input type="checkbox"/>	<input type="checkbox"/>	
Multi-state Value	<input checked="" type="checkbox"/>	<input type="checkbox"/>	<input type="checkbox"/>	Present value
Notification Class	<input checked="" type="checkbox"/>	<input type="checkbox"/>	<input type="checkbox"/>	Recipient_List
Program	<input type="checkbox"/>	<input type="checkbox"/>	<input type="checkbox"/>	
Schedule	<input type="checkbox"/>	<input type="checkbox"/>	<input type="checkbox"/>	

LonWorks Gateway

MIM-B18BUN

Features

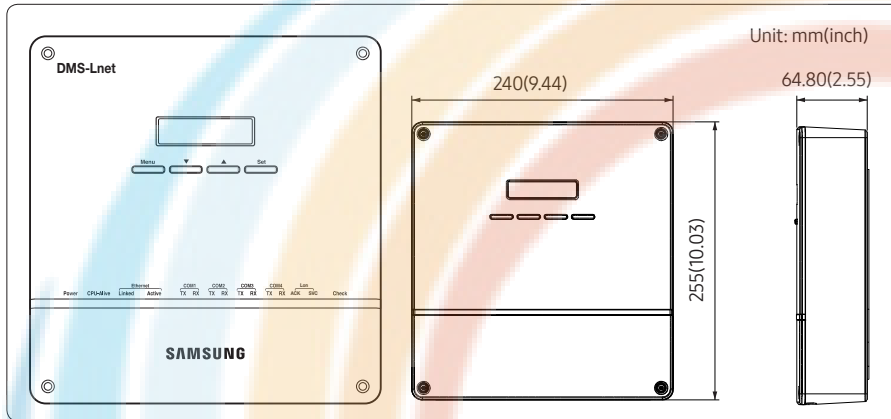

- For LonWorks protocol system.
- Support DMS2.5 control function at the same time.

Product specification

Power supply	Source	DC Adaptor		
	Input	100~240VAC (±10%), 50/60Hz		
	Output	12V 3A		
Operating temperature range		-10°C ~ 50°C (14°F~122°F)		
Operating humidity range		10%RH ~ 90%RH		
Communication connection		<ul style="list-style-type: none"> • Lower layer: RS485 x 5 • Upper layer: Ethernet100Base-T x 1 • LonWorks layer: TP/FT-10A(Free topology 78kbps) 		
External connection port	Digital Output	8		
	Digital Input	10		
Maximum length of connection	RS485	1000m (3280ft)		
	Digital Output	100m (328ft)		
	Digital Input	100m (328ft)		
	Ethernet	100m (328ft): When there is no repeater		
	LonWorks	500m (1640ft): When connecting with Bus type: 2700m (8858ft)		
Max. connectable number of device	Control layer	Device	Numbers per each channel	Total number for 5 channels
		Indoor units (including ERV, MCU, FCU KIT)	128	128
		Outdoor unit (including MIM-N01, MIM-N10, MIM-F10N, DVM CHILLER unit)	16	80
		OnOff controller	Total 15	Total 75
		Touch centralized controller		
		PIM interface module (MIM-B16UN)	8	8

LonWorks Gateway > MIM-B18BUN

Compatible product

Outdoor unit	AM****X****, AC****X****
Controller	OnOff controller (MCM-A202DUN)
	Touch centralized controller (MCM-A300UN)
	PIM interface module (MIM-B16UN)

- Conventional communication outdoor unit requires compatible interface module (MIM-N01) to establish connection
- MIM-B13D, MIM-B13E, MIM-B04A Interface modules cannot be connected.
- To connect ERV, MIM-N10 is required.
- To connect FCU KIT, MIM-F10N is required.
- Conventional PIM must connect to CH4(COM5) of DMS 2.5.

Description of parts

Front

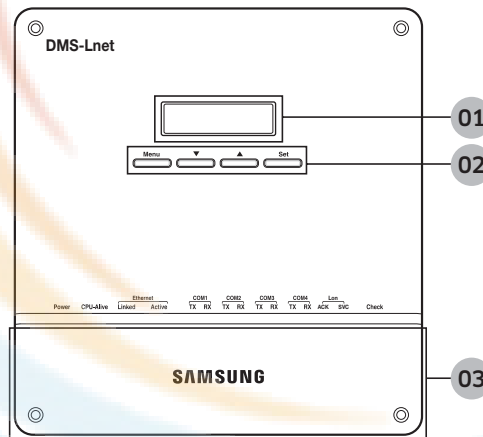

No.	Item	Function
01	LCD display	Displays current time or menu.
	Menu button	Access the setting menu.
02	▼/▲ button	Select function or setting item in the setting menu.
	Set button	Enter or check setting item in the setting menu.
03	Bottom cover	Unscrew 2 screws on the bottom to remove the cover and check the cable connections.

LonWorks Gateway > MIM-B18BUN

LED indicator

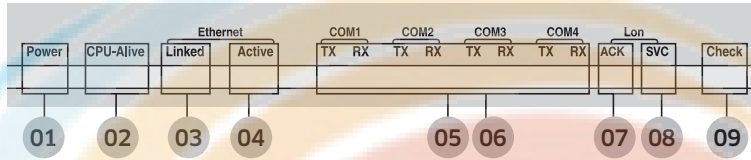

No.	Item	Name	Status
01	Power	Power indicator	Turns blue when the power is supplied.
02	CPU Alive	CPU operation indicator	Blinks in orange with 1 second intervals during normal operation.
03	Ethernet-Linked	Internet connection indicator	Turns green during normal connection.
04	Ethernet-Active	Internet data transmission/reception indicator	Blinks in orange during normal transmission/reception.
05	COM1~4-TX	Channel 1~4 OnOff controller/Interface module Data transmission indicator	Blinks in green during normal transmission.
06	COM1~4-RX	Channel 1~4 OnOff controller/interface module Data reception indicator	Blinks in green during normal reception.
07	Lon ACK	LonWorks data reception indicator	Blinks in green during normal reception.
08	Lon SVC	LonWorks device status indicator	Blinks in green during un-configured.
09	Check	Indoor/Outdoor unit communication status indicator	Turns green when there is an error on more than one indoor/outdoor unit or in communication.

LonWorks Gateway > MIM-B18BUN

Bottom

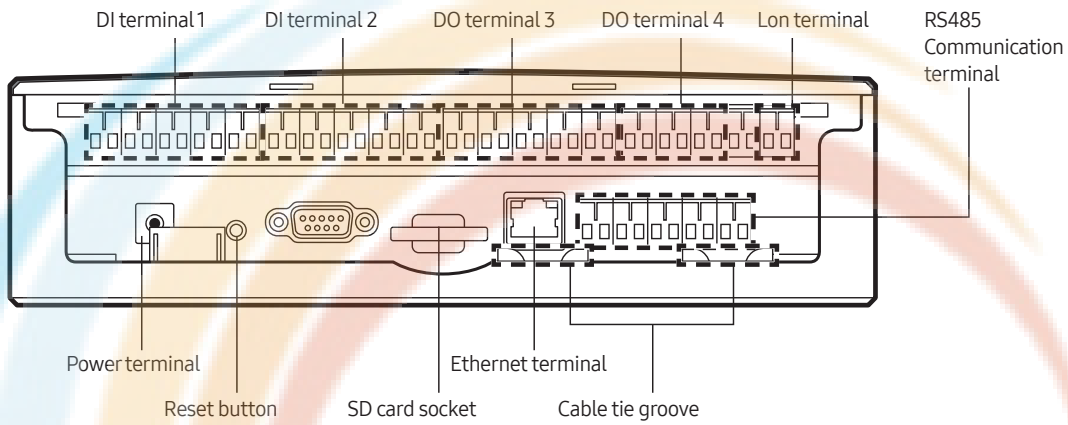

Name	Description
DI terminal 1	Digital Input connection terminal, Channel1~Channel5
DI terminal 2	Digital Input connection terminal, Channel6~Channel10
DO terminal 3	Digital Output connection terminal, Channel1~Channel5
DO terminal 4	Digital Output connection terminal, Channel6~Channel8
Lon terminal	Terminal Block for LonWorks communication (TP/FT-10)
Reset button	Reset LonWorks Gateway
SD card socket	Sub memory (for program update and set information saving) socket
RS485 communication terminal	RS485 port for communication with OnOff controller/interface module
Ethernet Terminal	Connect LAN cable
Cable tie groove	Groove for arranging cables

LonWorks Gateway > MIM-B18BUN

Connection diagram

MIM-B16UN(PIM) can be connected with outdoor units or controllers to same channel of DMS2.5.

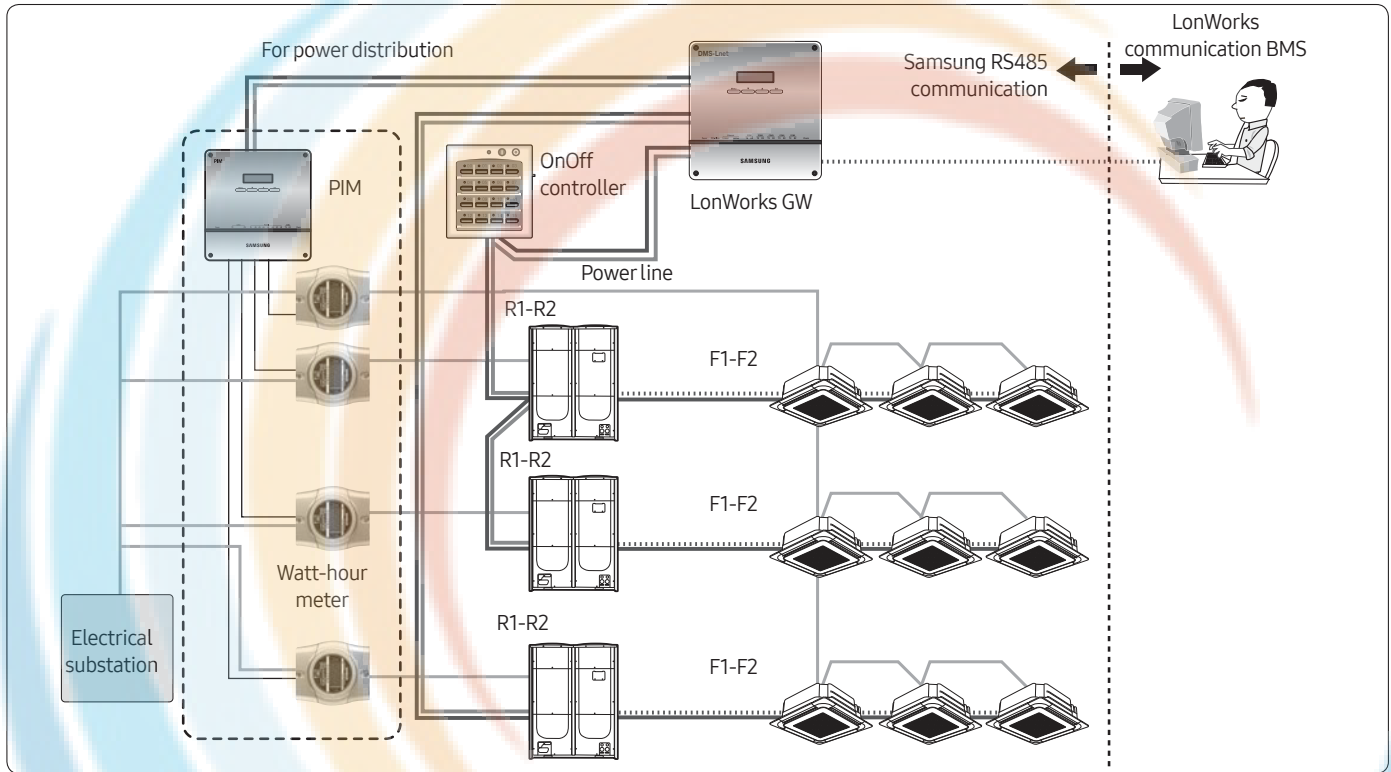

Wiring

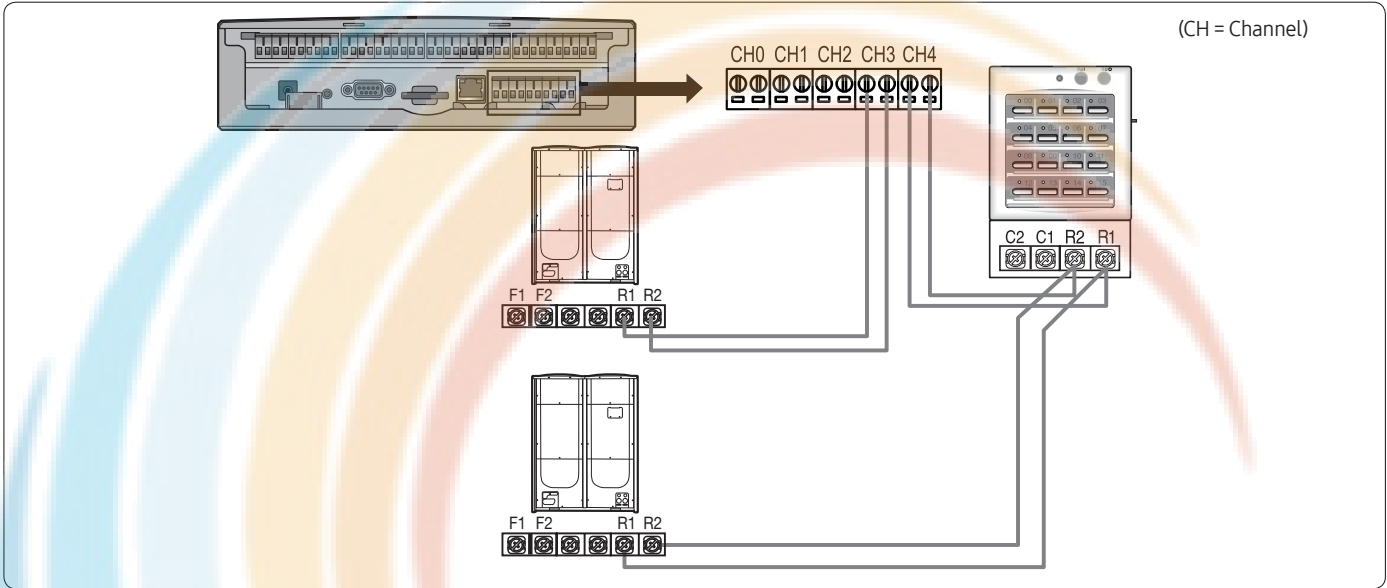

- **Connecting outdoor unit directly**
 - Maximum 16 outdoor units can be connected to each channel
 - Total 80 outdoor units can be connected
- **Connecting OnOff controller/Touch centralized controller**
 - Maximum 15 OnOff controller/Touch centralized controller can be connected to each channel

Note

- LonWorks gateway can connect outdoor unit and OnOff controller/Touch centralized controller at the same time.
- Outdoor unit and OnOff controller/Touch centralized controller can be connected to 1 communication channel at the same time.

LonWorks Gateway > MIM-B18BUN

Connecting with outdoor unit

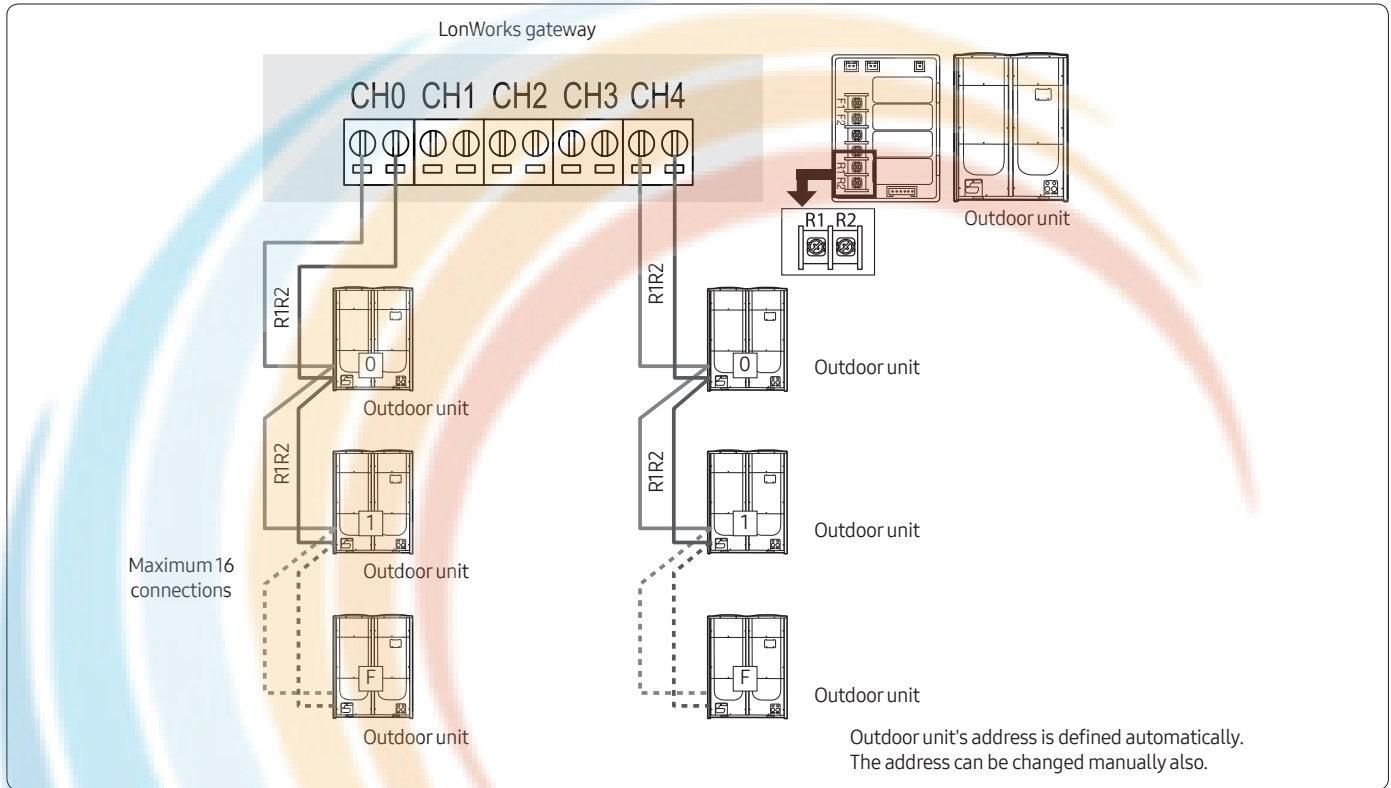

Connecting with OnOff controller

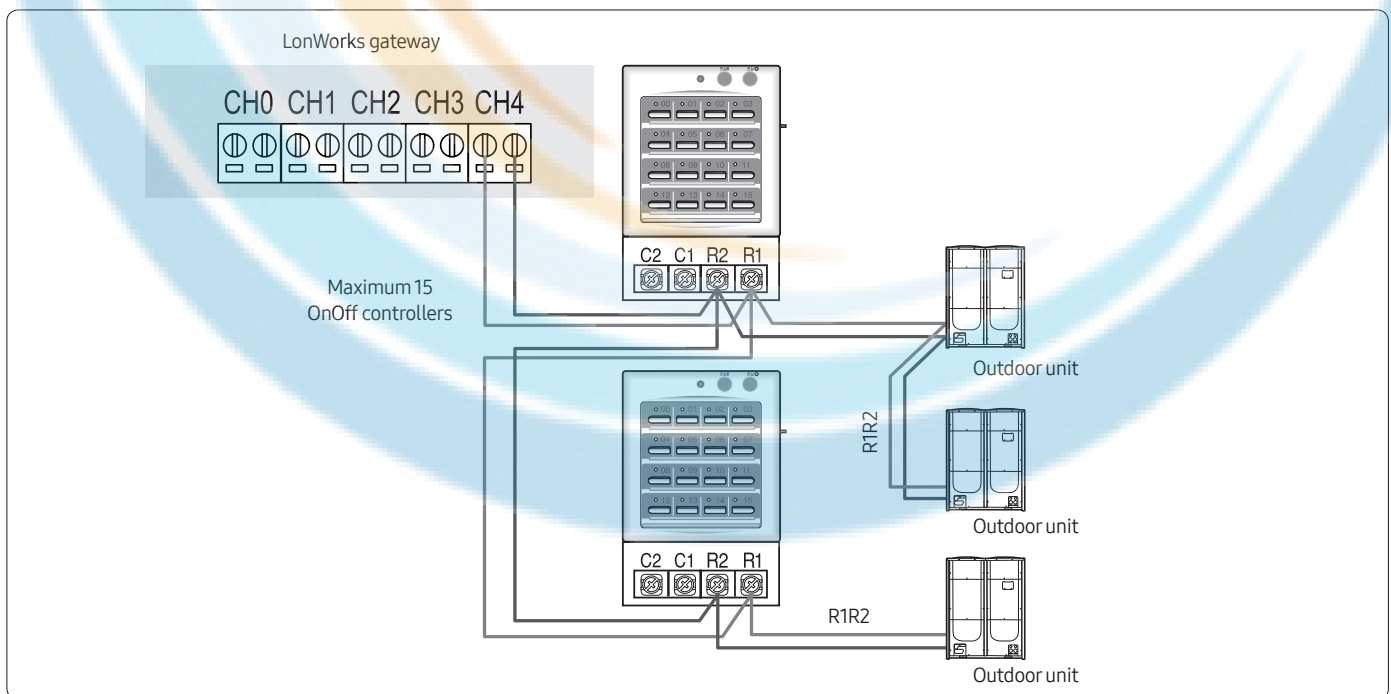

Connecting with outdoor unit and OnOff controller

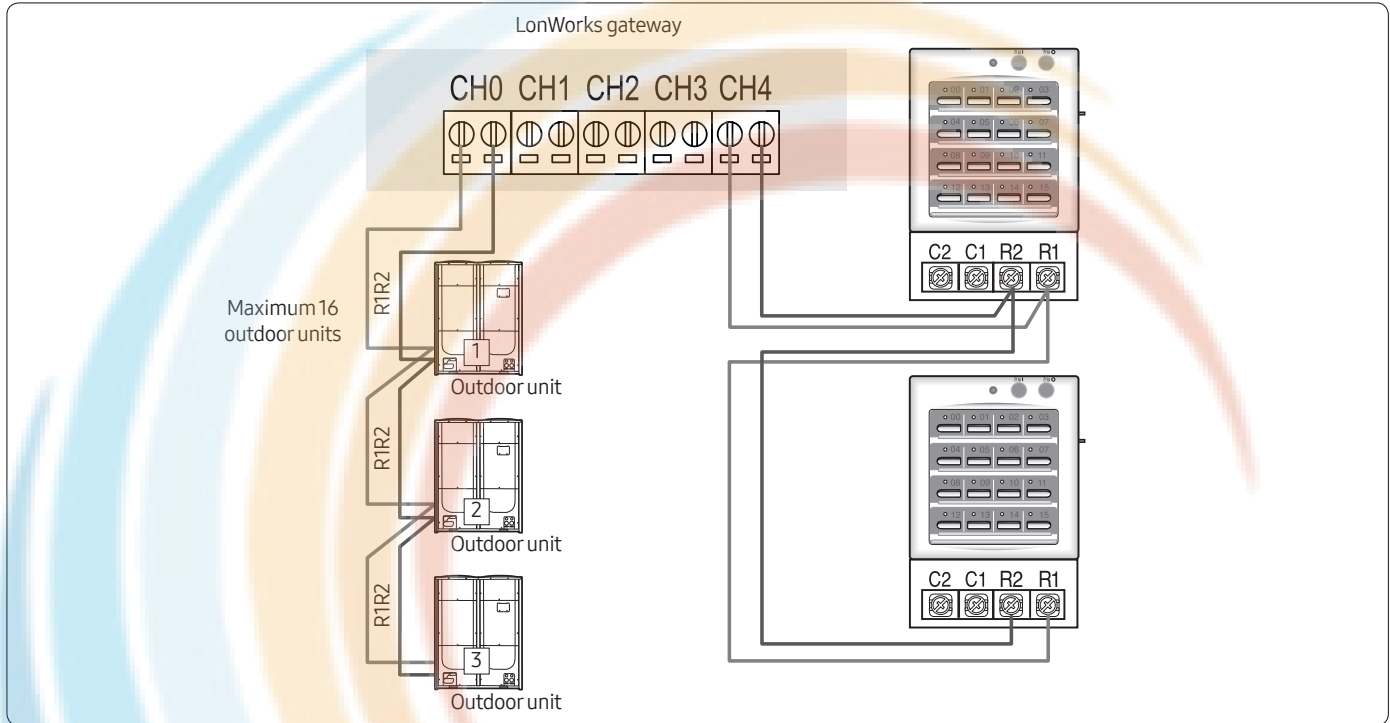

Wiring distance

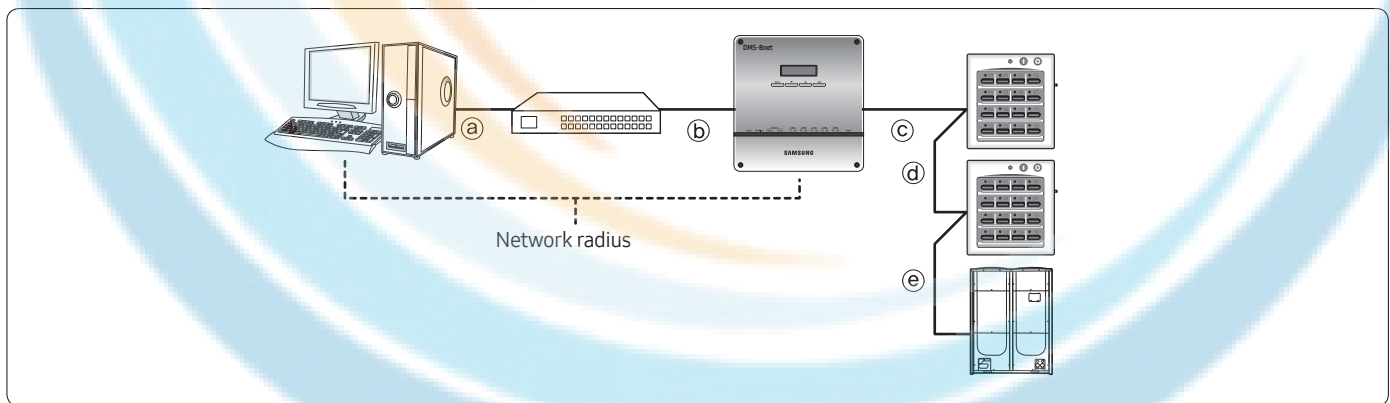

Distance between LonWorks gateway and OnOff controller/outdoor unit

- Distance from the LonWorks gateway to the furthest device cannot exceed 1000m(3280ft).
- © + @ + © ≤ 1000m(3280ft)

Distance between LonWorks gateway and upper level controller

- Since LonWorks GW supports 100 Base-T Ethernet, first repeater or upper level controller from the LonWorks GW cannot be further than 100m(328ft) (IEEE 802.3). Therefore, maximum network radius is restricted to 500m(1640ft).

LonWorks Gateway › MIM-B18BUN

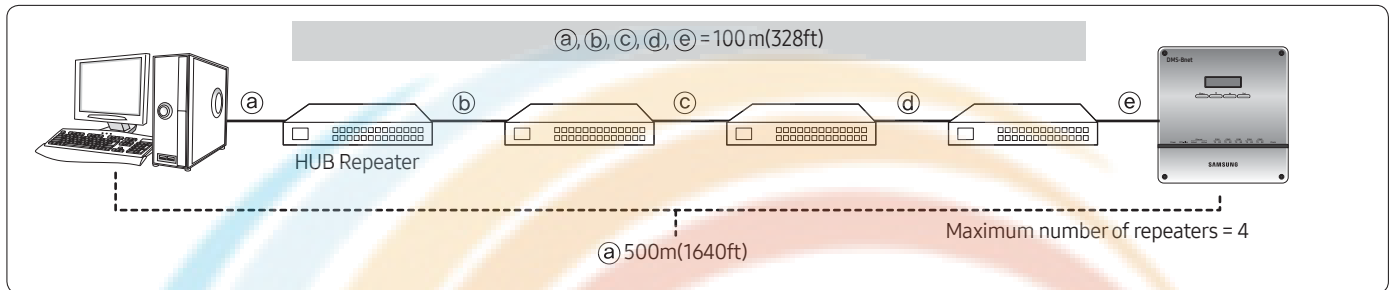

Commission

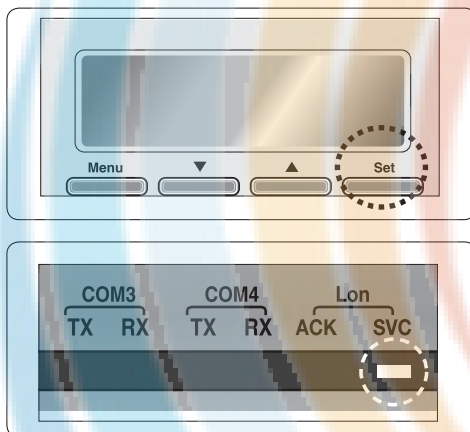

- To activate the Service Pin, press and hold [SET] button for more than three seconds while time is displayed in the LCD Display window of the front side of LonWorks Gateway.
- When you press Service Pin, Neuron ID will be sent and [SVC] LED of the front panel will be lit up for a second.

Standard program identifier (SPID)

- Manufacturers: Samsung Electronics Co., Ltd. MID: 191
- Device Classes: 70.00 - Gateways/72.80 --- HVAC Gateways
- Usage (Device Subclass): Utility {11}
- Channel Types: TP/FT-10 {ID: 4}

Object Types	Description	SFPT Name
8500	SCC – Generic	SFPTspaceComfortController

- Program ID: 90:00:BF:48:50:0B:04:00

Item summary

Item		Function
Control & Monitoring	Common	Operation On/Off
		Operation mode
		Air flow direction
		Fan speed
		Device error information
		Model, address, type information
	Indoor unit AHU	Set temperature
		Indoor temperature
		Filter replacement alert/reset
		Remote controller level
		Thermostat information
		Operation restriction setting (Cooling/Heating)
		Setting lowest temperature/restriction
		Setting highest temperature/restriction
	Additional functions	Power consumption
		Operation time
		Emergency stop
		DMS2.5 DI/DO
		DMS2.5 lock
		DMS2.5 error information
	System error information	

Network variable

Indoor unit/ERV/AHU kit/Fresh duct/DVM Chiller/FCU Kit

No.	Name	Type	M/O	Description
1	nviONOff	SNVT_switch	0	ON/OFF command
2	nviApplicMode	SNVT_hvac_mode	0	Setting operating mode
3	nviSetpoint	SNVT_temp_p	0	Setting desire temperature
4	nviFanStatus	SNVT_switch	0	Setting fan speed
5	nviERVMode	SNVT_count	0	Setting ERV operation mode
6	nviFilterReset	SNVT_switch	0	Filter reset command
7	nviUserLockout	SNVT_switch	0	Setting the restriction of remote control use
8	nviOccOpMode	SNVT_switch	0	Setting cooling only mode/heating only mode
9	nviCoolTempLock	SNVT_switch	0	Setting the low temperature limit
10	nviHeatTempLock	SNVT_switch	0	Setting the high temperature limit
11	nvoSpaceTemp	SNVT_temp_p	M	Display indoor temperature
12	nvoApplicMode	SNVT_hvac_mode	0	Display operating mode
13	nvoSetpoint	SNVT_temp_p	0	Display desire temperature
14	nvoOnOff	SNVT_switch	0	Display ON/OFF status
15	nvoFanStatus	SNVT_switch	0	Display fan speed
16	nvoERVMode	SNVT_count	0	Display ERV operating mode
17	nvoErrorCode	SNVT_count	0	Display Error code
18	nvoDeviceAlarm	SNVT_state	0	Remote control lock, Filter sign, Thermo ON/OFF, Error occurrence status display
19	nvoOccOpMode	SNVT_switch	0	Cooling only/Heating only setup status display
20	nvoCoolTempLock	SNVT_switch	0	Display low temperature limit setting status
21	nvoHeatTempLock	SNVT_switch	0	Display high temperature limit setting status
22	nvoUserLockout	SNVT_switch	0	Display the restriction of remote control use
23	nvoEnergyComp	SNVT_elec_kwh_l	0	Display electricity usage (Time Period)
24	nvoEnergyCon	SNVT_elec_kwh_l	0	Display electricity usage (Basic date)
25	nvoRuntimep	SNVT_time_hour	0	Display used hours (Period)
26	nvoRuntime	SNVT_time_hour	0	Display used hours (Basic date)
27	nvoDevListDesc	SNVT_str_asc	0	Indoor unit HW information

■ DVM system object

No.	Name	Type	M/O	Description
1	nviDigitalOut[6]	SNVT_switch	0	Control Digital output of DMS
2	nviAllOff	SNVT_hvac_emerg	0	Control all indoor unit/ERV OFF
3	nvoDigitalOut[6]	SNVT_switch	0	Display Digital output status of DMS
4	nvoDigitalIn[8]	SNVT_switch	0	Display Digital input status of DMS
5	nvoSystemLock	SNVT_switch	0	Display System Lock status of DMS
6	nvoDMS2Alarm	SNVT_count	0	Display communication error of the sub device connected to DMS
7	nvoSystemAlarm	SNVT_count	0	

■ Configuration properties

No.	Name	Type	M/O	Description
1	nciSndHrtBt	SNVT_time_sec SCPTmaxSendTime	0	Send Heartbeat
2	nciMinOutTm	SNVT_time_sec SCPTminSendTime	0	Minimum Send Time
3	nciMinDeltaTemp	SNVT_temp_p SCPTminDeltaTemp	0	Min. difference before update
4	nciDelayStatrup	SNVT_time_sec SCPTpwrupDelay	0	Delay time after a power-up

Network parameter chart

Indoor unit/ERV/AHU/DVM Chiller/FCU kit object

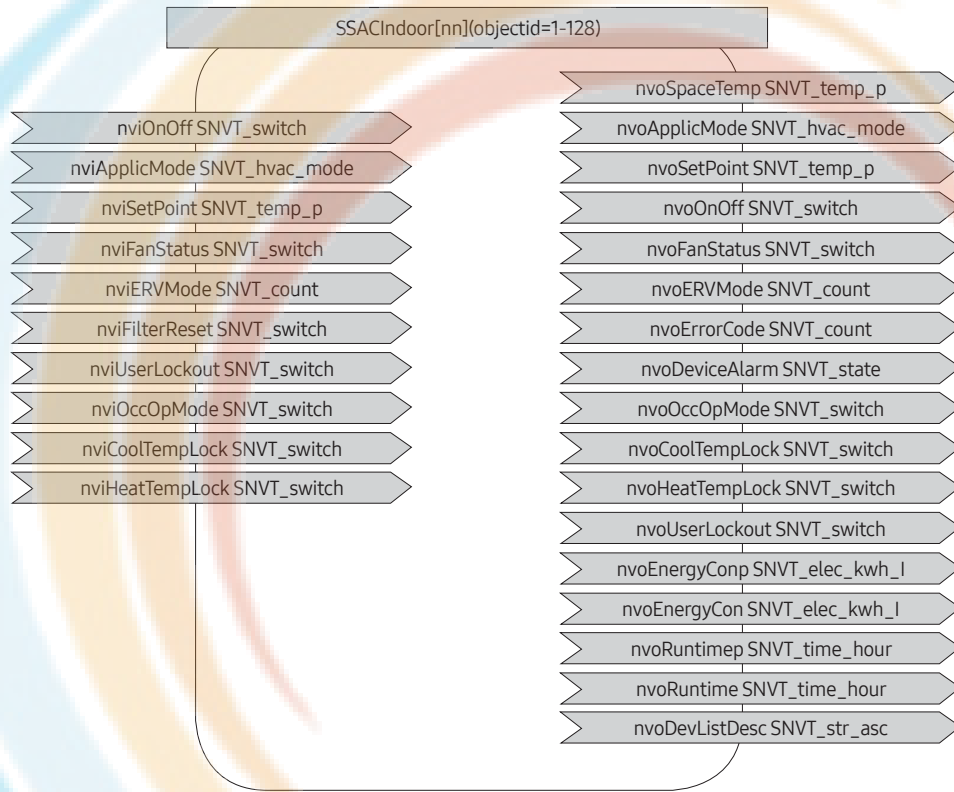

Indoor unit/ERV/AHU/DVM Chiller/FCU kit object

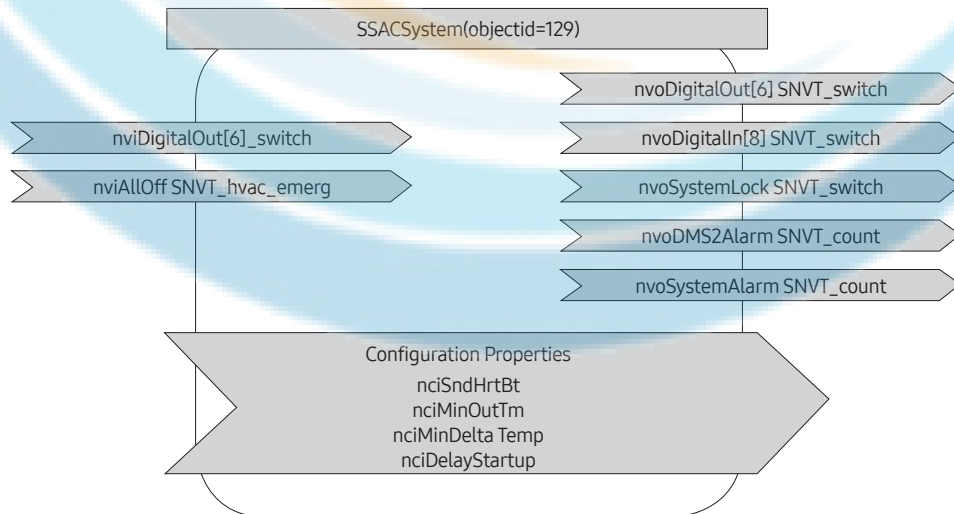

Control and Monitoring Item

Functional classification by a device.

The functions provided can be different according to the type of the connected device.

No	NVName	Remarks	Indoor	ERV	AHU Kit	Fresh Duct	DVM Chiller	FCU Kit
1	nviOnOff	ON/OFF Command	0	0	0	0	0	0
2	nviApplicMode	Setting operation mode	0	X	0	0	0	0
3	nviSetpoint	Setting desirable temperature	0	X	0	X	0	0
4	nviFanStatus	Setting wind speed and direction	0	0	X	X	X	0
5	nviERVMode	Setting ERV operation mode	X	0	X	X	X	X
6	nviFilterReset	Filter reset command	0	0	0	0	X	X
7	nviUserLockout	Setting the restriction of remote control use	0	0	0	0	0	0
8	nvoOccOpMode	Setting cooling only mode/Setting heating only mode	0	X	0	0	X	0
9	nviCoolTempLock	Setting the low temperature limit	0	X	0	X	X	0
10	nviHeatTempLock	Setting the high temperature limit	0	X	0	X	X	0
11	nvoSpaceTemp	Display indoor temperature	0	X	0	X	0	0
12	nvoApplicMode	Display operating mode	0	X	0	0	0	0
13	nvoSetPoint	Display desire temperature	0	X	0	X	0	0
14	nvoOnOff	Display ON/OFF status	0	0	0	0	0	0
15	nvoFanStatus	Display wind speed and direction	0	0	X	X	X	0
16	nvoERVMode	Display ERV operating mode	X	0	X	X	X	X
17	nvoErrorCode	Display Error code	0	0	0	0	0	0
18	nvoDeviceAlarm	Remote control Lock, Filter Sign, Thermo ON/OFF, Error occurrence status display	0	0	0	0	0	0
19	nvoOccOpMode	Cooling only/Heating only setup status display	0	X	0	0	X	0
20	nvoCoolTempLock	Low temperature limit setting status display	0	X	0	X	X	0
21	nvoHeatTempLock	High temperature limit setting status display	0	X	0	X	X	0
22	nvoUserLockout	Display the restriction of remote control use	0	0	0	0	0	0
23	nvoEnergyCon_p	Display electricity usages(Time Period)	0	X	X	X	X	X
24	nvoEnergyCon	Display electricity usages(Basic date)	0	X	X	X	X	X
25	nvoRuntime_p	Display used hours(Period)	0	X	0	X	0	0
26	nvoRuntime	Display used hours(Basic date)	0	X	0	X	0	0
27	nvoDevListDesc	The summary of device information(Model, Address, Operation Status)	0	0	0	0	0	0

Detail description of network variable

Indoor unit/ERV/AHU/DVM Chiller/FCU kit object

1-1. nvoSpaceTemp(11)

Description	Indoor temperature
SNVT Type	SNVT_temp_p: Signed Long, 2 bytes
Value and operation	Range : -10.0°C(14°F) ~ 50.0°C(122°F)

1-2. nvoApplicMode(12), nviApplicMode(2)

Description	Operation Mode status
SNVT Type	SNVT_hvac_mode: Enumeration(hvac_t)
Value and operation	0: HVAC_AUTO 1: HVAC_HEAT 3: HVAC_COOL 6: HVAC_OFF 9: HVAC_FAN_ONLY 11: HVAC_ICE(Cool Storage) 13: HVAC_ECONOMY(Hot Water) 14: HVAC_DEHUMID

- Invalid Value: Automatically set as HVAC_AUTO

1-3. nvoSetpoint(13), nviSetpoint(3)

Description	Set Temperature
SNVT Type	SNVT_temp_p: Signed Long, 2 bytes
Value and operation	Cool: 18.0°C(64.4°F) ~ 30.0°C(86.0°F), Heat: 16.0°C(60.8°F) ~ 30.0°C(86.0°F) DVM Chiller : -10°C(14°F) ~ 55°C(131°F)

- Invalid Value: Automatically set up as minimum or maximum value.
- When setting temperature, only an integer value is applied. A decimal point is ignored.

1-4. nvoOnOff(14), nviOnOff(1)

Description	Power ON/OFF status		
SNVT Type	SNVT_switch: Unsigned/signed Short		
Value and operation		Value	State
	OFF	0.0	0
	ON	100.0	1

1-5. nvoFanStatus(15), nviFanStatus(4)

Description	Fan Speed and direction		
SNVT Type	SNVT_switch: Unsigned/signed Short		
Value and operation		Value	State
	Auto	0.0	-
	Low	1.0	-
	Mid	2.0	-
	High	3.0	-
	Eco	4.0	-
	Turbo	5.0	-
	Auto	Any>5.0	-
	Stop	-	0
	Up-Down	-	1

- Supporting modes are different according to indoor units.
 - Indoor unit: Auto, Low, Mid, High (Turbo: Optional)
 - ERV: Mid, High, Turbo
 - FCU Kit : Auto, Low, Mid, High
 - AHU Kit: High
- When an indoor unit operation mode is Auto or Dehumid, Fan speed is controlled as 'Auto'.
- When an indoor unit operation mode is FAN ONLY, 'Auto' cannot be controlled by Fan speed.

1-6. nvoERVMode(16), nviERVMode(5)

Description	ERV Operation Mode
SNVT Type	SNVT_count: Unsigned Long, 2 bytes
Value and operation	(0: Auto) 1: H/R (2: Air purification) 3: Sleep 4: Normal

• (): Function that is not supported now.

1-7. nvoErrorCode(17)

Description	Error Code
SNVT Type	SNVT_count: Unsigned Long, 2 bytes
Value and operation	Valid Range: 0 ~ 999 00 00 → No Error Refer to list of Error code

1-8. nvoDeviceAlarm(18)

Description	1. Remote control restriction status 2. Filter alert status 3. Thermo On/Off status 4. Error alert Status																																													
SNVT Type	SNVT_state: 16 Unsigned Bitfields																																													
Value and operation	<table border="1"> <thead> <tr> <th>Byte</th> <th>Bit9</th> <th>Bit8</th> <th>Operation</th> <th>Remark</th> </tr> </thead> <tbody> <tr> <td rowspan="3">Flags _1</td> <td>0</td> <td>0</td> <td>Unlock</td> <td>nvo User</td> </tr> <tr> <td>0</td> <td>1</td> <td>Level1</td> <td>Lockout</td> </tr> <tr> <td>1</td> <td>0</td> <td>Lock</td> <td></td> </tr> <tr> <th>Byte</th> <th>Bit9</th> <th>Bit8</th> <th>Operation</th> <th>Remark</th> </tr> <tr> <td rowspan="6">Flags _2</td> <td rowspan="2">2</td> <td>0</td> <td>No alarm</td> <td>nvo Filter Alarm</td> </tr> <tr> <td>1</td> <td>Alarm</td> <td></td> </tr> <tr> <td rowspan="2">1</td> <td>0</td> <td>Thermo Off</td> <td>Thermo On/Off</td> </tr> <tr> <td>1</td> <td>Thermo On</td> <td></td> </tr> <tr> <td rowspan="2">0</td> <td>0</td> <td>No Error</td> <td>nvo Error Code</td> </tr> <tr> <td>1</td> <td>Error</td> <td></td> </tr> </tbody> </table>	Byte	Bit9	Bit8	Operation	Remark	Flags _1	0	0	Unlock	nvo User	0	1	Level1	Lockout	1	0	Lock		Byte	Bit9	Bit8	Operation	Remark	Flags _2	2	0	No alarm	nvo Filter Alarm	1	Alarm		1	0	Thermo Off	Thermo On/Off	1	Thermo On		0	0	No Error	nvo Error Code	1	Error	
Byte	Bit9	Bit8	Operation	Remark																																										
Flags _1	0	0	Unlock	nvo User																																										
	0	1	Level1	Lockout																																										
	1	0	Lock																																											
Byte	Bit9	Bit8	Operation	Remark																																										
Flags _2	2	0	No alarm	nvo Filter Alarm																																										
		1	Alarm																																											
	1	0	Thermo Off	Thermo On/Off																																										
		1	Thermo On																																											
	0	0	No Error	nvo Error Code																																										
		1	Error																																											

1-9. nvoOccOpMode(19), nviOccOpModeCmd(8)

Description	Operation Mode restriction												
SNVT Type	SNVT_switch: Unsigned/signed Short												
Value and operation	<table border="1"> <thead> <tr> <th></th> <th>Value</th> <th>State</th> </tr> </thead> <tbody> <tr> <td>Unlock</td> <td>0.0</td> <td>0</td> </tr> <tr> <td>Cool only</td> <td>1.0</td> <td>1</td> </tr> <tr> <td>Heat only</td> <td>2.0</td> <td>1</td> </tr> </tbody> </table>		Value	State	Unlock	0.0	0	Cool only	1.0	1	Heat only	2.0	1
	Value	State											
Unlock	0.0	0											
Cool only	1.0	1											
Heat only	2.0	1											

1-10. nvoCoolTempLock(20), nviCoolTempLock(9)

Description	Setting/monitoring Lower limit temperature and function toggle									
SNVT Type	SNVT_switch: Unsigned/signed Short									
Value and operation	<table border="1"> <thead> <tr> <th>Operation</th> <th>Value</th> <th>State</th> </tr> </thead> <tbody> <tr> <td>Unlock</td> <td>18.0 ~ 30.0</td> <td>0</td> </tr> <tr> <td>Lock</td> <td>18.0 ~ 30.0</td> <td>1</td> </tr> </tbody> </table> <p>Cool: 18.0°C(64.4°F) ~ 30.0°C(86.0°F)</p>	Operation	Value	State	Unlock	18.0 ~ 30.0	0	Lock	18.0 ~ 30.0	1
Operation	Value	State								
Unlock	18.0 ~ 30.0	0								
Lock	18.0 ~ 30.0	1								

1-11. nvoHeatTempLock(21), nviHeatTempLock(10)

Description	Setting/monitoring upper limit temperature and function toggle									
SNVT Type	SNVT_switch: Unsigned/signed Short									
Value and operation	<table border="1"> <thead> <tr> <th>Operation</th> <th>Value</th> <th>State</th> </tr> </thead> <tbody> <tr> <td>Unlock</td> <td>16.0 ~ 30.0</td> <td>0</td> </tr> <tr> <td>Lock</td> <td>16.0 ~ 30.0</td> <td>1</td> </tr> </tbody> </table> <p>Heat: 16.0°C(60.8°F) ~ 30.0°C(86.0°F)</p>	Operation	Value	State	Unlock	16.0 ~ 30.0	0	Lock	16.0 ~ 30.0	1
Operation	Value	State								
Unlock	16.0 ~ 30.0	0								
Lock	16.0 ~ 30.0	1								

1-12. nvoEnergyComp(23)

Description	Electric consumption value within the period
SNVT Type	SNVT_elec_kwh_l: Signed Quad, 4bytes
Value and operation	Raw range: 0 ~ 999999 Resolution: 0.1

1-13. nvoEnergyCon(24)

Description	Electric consumption value after baselin
SNVT Type	SNVT_elec_kwh_l: Signed Quad, 4bytes
Value and operation	Raw range: 0 ~ 999999 Resolution: 0.1

1-14. nvoRunTimep(25)

Description	Indoor unit usage within the period
SNVT Type	SNVT_time_hour: Signed Long, 2bytes
Value and operation	Raw range: 0 ~ 65535

1-15. nvoRunTime(26)

Description	Indoor unit usage after baseline
SNVT Type	SNVT_time_hour: Signed Long, 2bytes
Value and operation	Raw range: 0 ~ 65535

- Energy consumption and Runtime are the accumulated value during the user setting period.
- The data above is for reference so you can not use them for official billing.

1-15. nviFilterReset(6)

Description	Filter alert reset												
SNVT Type	SNVT_time_hour: Signed Long, 2bytes												
Value and operation	<table border="1"> <thead> <tr> <th>Value</th> <th>State</th> <th>Operation</th> <th>remark</th> </tr> </thead> <tbody> <tr> <td>0.0</td> <td>0</td> <td>No Action</td> <td></td> </tr> <tr> <td>100.0</td> <td>1</td> <td>Filter Reset</td> <td></td> </tr> </tbody> </table>	Value	State	Operation	remark	0.0	0	No Action		100.0	1	Filter Reset	
Value	State	Operation	remark										
0.0	0	No Action											
100.0	1	Filter Reset											

1-15. nviUserLockout(7), nvoUserLockout(22)

Description	Remote control restriction																
SNVT Type	SNVT_switch: Unsigned/signed Short																
Value and operation	<table border="1"> <thead> <tr> <th>Value</th> <th>State</th> <th>Operation</th> <th>remark</th> </tr> </thead> <tbody> <tr> <td>0.0</td> <td>0</td> <td>Unlock</td> <td></td> </tr> <tr> <td>100.0</td> <td>1</td> <td>Level1</td> <td></td> </tr> <tr> <td>100.0</td> <td>2</td> <td>Lock</td> <td></td> </tr> </tbody> </table>	Value	State	Operation	remark	0.0	0	Unlock		100.0	1	Level1		100.0	2	Lock	
Value	State	Operation	remark														
0.0	0	Unlock															
100.0	1	Level1															
100.0	2	Lock															

1-15. nvoDevListDesc(27)

Description	Device Information
SNVT Type	SNVT_str_asc: Unsigned Character Array, 31bytes
Value and operation	Refer to Expansion of nvoDevListDesc

Indoor unit/ERV/AHU/DVM Chiller/FCU kit object

Expansion of nvoDevListDesc

		desription	character	value
ascii.	[0]	Model information	Alphabet or digit	
	[1]		Alphabet or digit	
	[2]		Alphabet or digit	
	[3]		Alphabet or digit	
	[4]		Alphabet or digit	
	[5]		Alphabet or digit	
	[6]	Separator	Underbar(_)	095
	[7]	Centralized controller address	Alphabet or digit	
	[8]		Alphabet or digit	
	[9]	Separator	Period(.)	046
	[10]	Interface Module address	Alphabet or digit	
	[11]		Alphabet or digit	
	[12]	Separator	Period(.)	046
	[13]	Indoor Unit Address	Alphabet or digit	
	[14]		Alphabet or digit	
	[15]	Separator	Underbar(_)	095
	[16]	Unit type	0: indoor unit, 1: AHU, 2: ERV	
	[17]	Separator	Underbar(_)	095
	[18]	Operation mode	DMS Format 0: Auto, 1: Cool, 2: Dehumid, 3: Fan, 4: Heat, 5: Cool Storage, 6: Hot Water	
	[19]	ON/OFF	0, 1	
	[20]	Fan speed	0, 1, 2, 3, 4, 5	
	[21]	Fan Swing	0, 1	
	[22]	Error	0, 1	
	[23]	Separator	Underbar(_)	095
	[24]	setPoint temperate	Second significant digit	
	[25]		First significant digit	
	[26]		First decimal place	
	[27]	Space temperate(*)	Second significant digit	
	[28]		First significant digit	
	[29]		First decimal place	
[30]	Null padding	0	048	

- (*) If the value is a negative number, it is displayed as sign, 10-digit, single-digit.

DMS System object

2-1. nvoDigitalOut(3), nviDigitalOut(1)

Description	Digital output status on DMS		
SNVT Type	SNVT_switch: Unsigned/signed Short		
Value and operation		Value	State
	OFF	0.0	0
	ON	100.0	1

2-2. nvoDigitalIn(4)

Description	Digital Input status on DMS		
SNVT Type	SNVT_switch: Unsigned/signed Short		
Value and operation		Value	State
	OFF	0.0	0
	ON	100.0	1

2-3. nvoSystemLock(5)

Description	System lock status of DMS(only monitoring available)		
SNVT Type	SNVT_switch: Unsigned/signed Short		
Value and operation		Value	State
	Unlock	0.0	0
	Lock	100.0	1

2-4. nvoDMSAlarm(6)

Description	DMS Alarm
SNVT Type	SNVT_count: Unsigned Long, 2 bytes
Value and operation	0: Normal
	8: Emergency stop
	105: Tracing in progress
	108: Tracking failed
	109: Lon Module ↔ DMS2.5 communication Error
	110: Object ID Update

2-5. nvoSystemAlarm(7)

Description	SIM/PIM Communication Error Code
SNVT Type	SNVT_count: Unsigned Long, 2 bytes
Value and operation	SIM/PIM Communication Error Refer to list of Error code

2-6. nviAllOff(2)

Description	DMS Alarm
SNVT Type	Enumeration, emerg_t
Value and operation	0: EMERG_NORMAL
	4: EMERG_SHUTDOWN

External Contact Interface Module

MIM-B14

Features

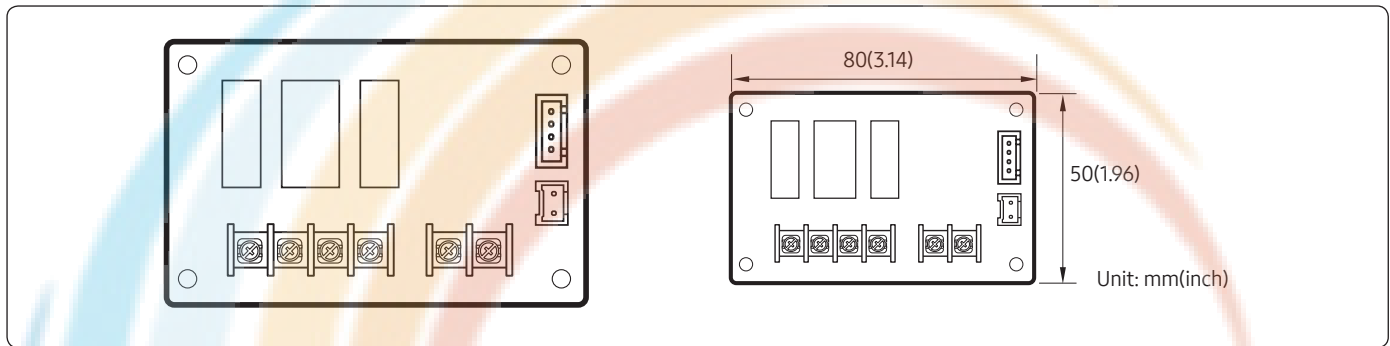

Interlock DVM air-conditioner with external controller

- Indoor unit On/Off control by the external contact (Usable equipment: Card-key, Timer, External Room sensor, Motion Detector Sensor)
- Output the indoor unit thermo ON/OFF state and operation status
- Output the indoor unit error state

Description of parts

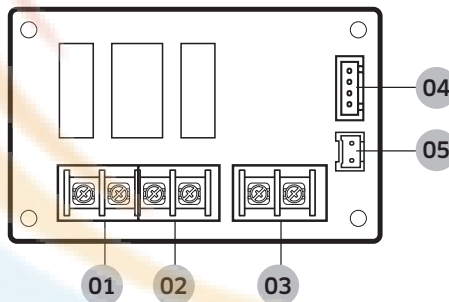

No.	Input/Output	Contact rating	Operation
01	Error state	220V AC, 3A	Normal:Close, Error:Open
02	Indoor unit Thermo On/Off or Operation State output (It depends on indoor unit's INSTALL option setting SEG 15.)	220V AC, 3A	[Output signal] SEG 15 = 0 Thermo On/Off SEG 15 =1 Operation On/Off (On:contact close, Off:contact open)
03	Operation signal input load	5V DC, 5mA	-
04	Connector for indoor unit	-	-
05	Connector for indoor unit	-	-

Installation

External contact line wiring

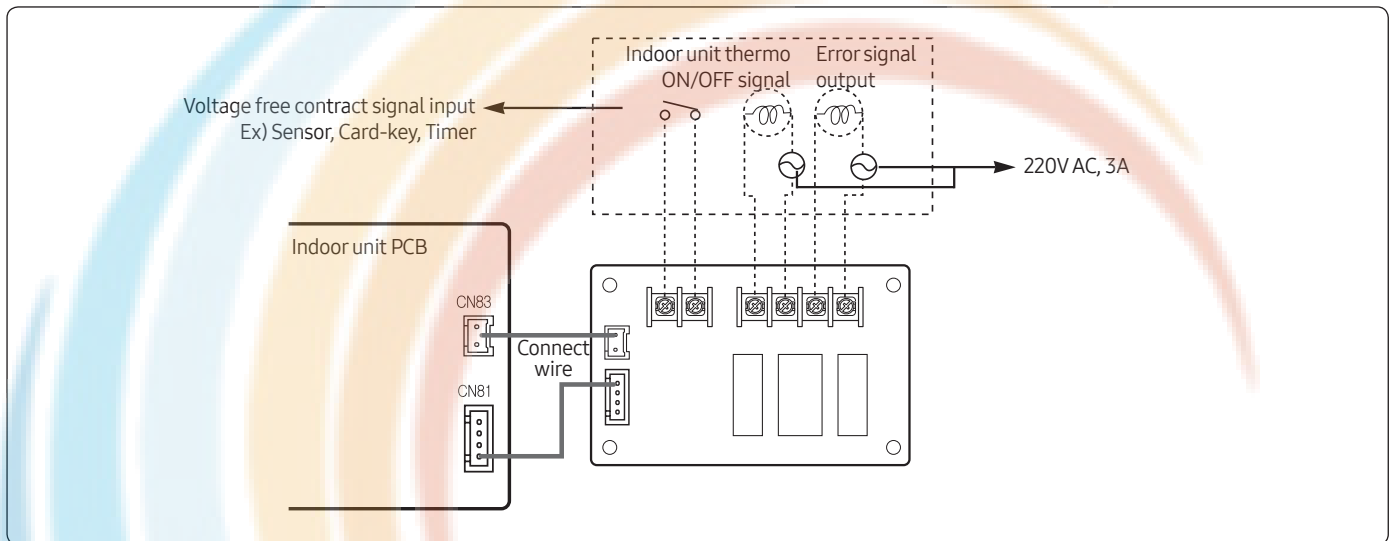

Note

- External operation input load: 5V DC/5mA.
- The length of wiring between MIM-B14 and external control equipment is 100m(328ft) max.
- To use external contact control system, indoor unit's INSTALL option setting is required. (Refer to indoor unit installation manual)
 - SEG14 - External control setting (Default: No use)
- After installed, the first operation will be conducted with Auto mode, Set temp. 24°C(75°F), Auto Fan speed.
- If the indoor unit in OFF status is turned ON through external contact signal; it will operate in the last operation status before it was turned off.

For controlling external heater (On/Off)

Circuit diagram for using external heater for the indoor units without hot water coil terminal

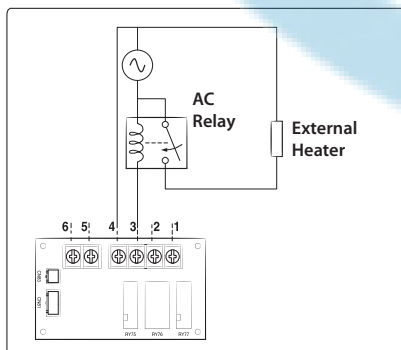

- Detailed method about Installation option establishment refers to Indoor Unit manual. (External contact control setting: Refer to SGE14, SGE15 of 02 Series installation option External heater control setting: Refer to SEG15 of 02 Series Installation Option and SEG18 of 05 Series installation option))
- Dry contact(no power source contact) must be connected to the input terminal 5,6.
- When MIM-B14 is used for controlling external heater, its contact should not be connected directly to the load. (Only use as switch as shown in above diagram.)

Control

Timing diagram for external contact control

• Ex1)

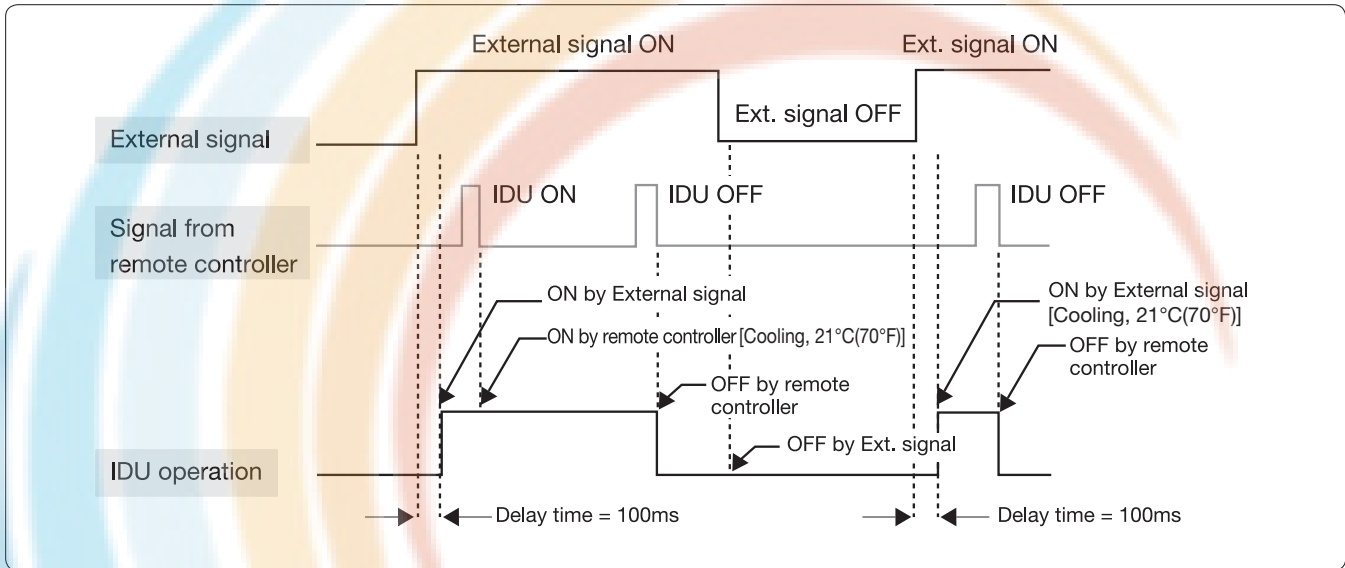

Note

- IDU stands for Indoor Unit.
No prioritized operation between the R/C and the external contact I/M.

• Ex2)

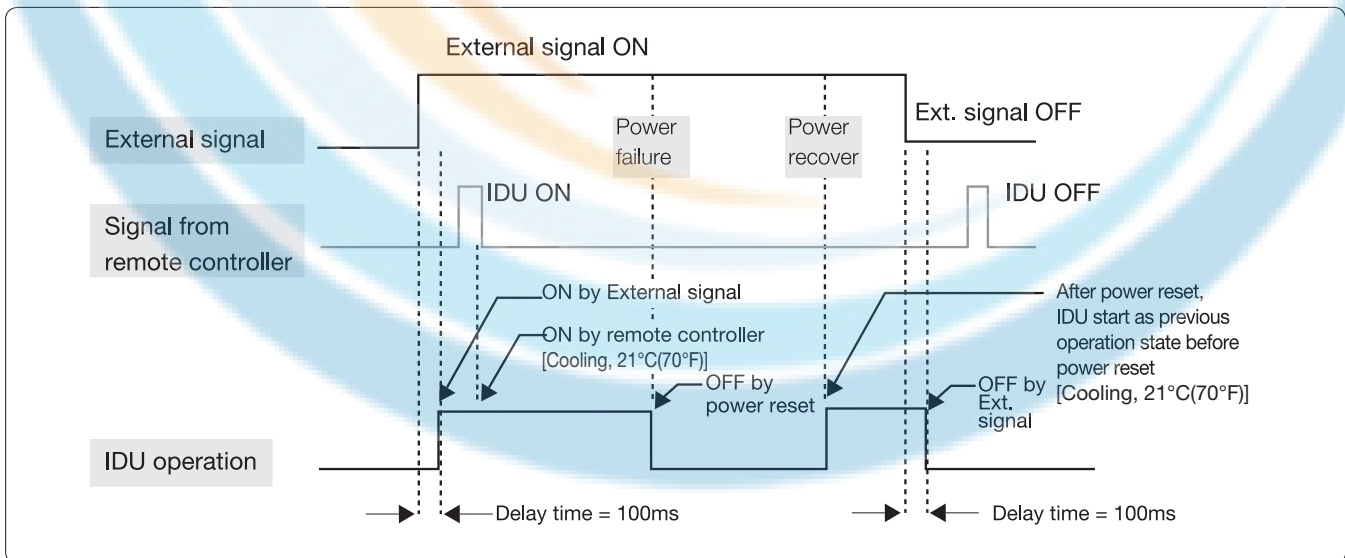

Note

- IDU stands for Indoor Unit.
After power reset, indoor unit operates as previous state. (IDU has power recovery function)

External Contact Interface Module > MIM-B14

Ex3)

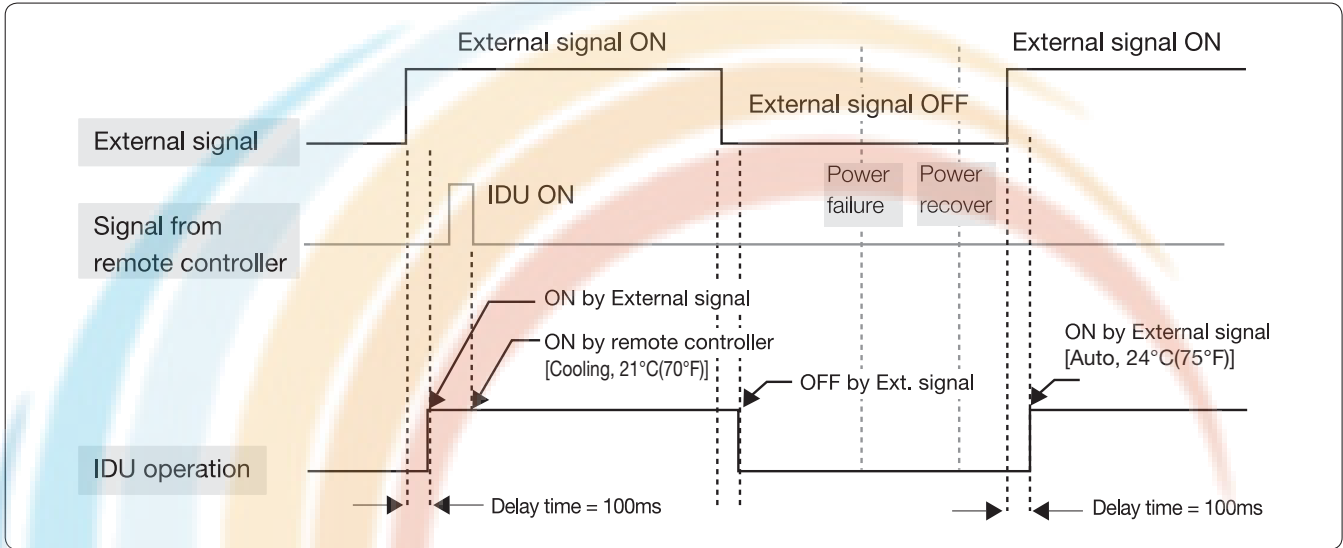

Note

- IDU stands for Indoor Unit.
After power reset, if IDU is turn ON by external contact, it starts as Auto mode, 24°C(75°F), Auto fan speed.

Ex4)

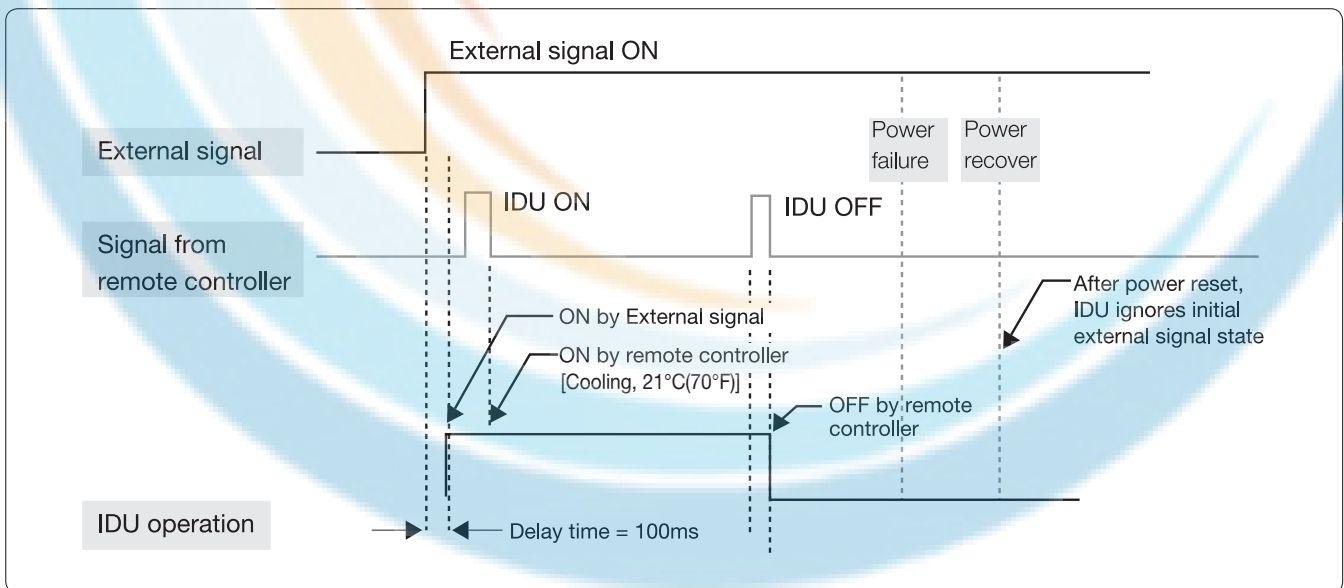

Note

- IDU stands for Indoor Unit.
After power reset, IDU ignores initial external signal state.

External Contact Interface Module › MIM-B14

Operation input

It is possible to set the method of indoor unit control by external contact signal.

- Method 1. Turn On/Off the indoor units by external contact signal
- Method 2. Set standby/Turn Off the indoor unit by external contact signal
- Method 3. Return to the last status/Turn Off the indoor unit by external contract signal

	Method 1	Method 2	Method 3
Indoor unit INSTALL option setting (Refer to indoor unit installation manual)	SEG 14 = 1	SEG 14 = 2	SEG 14 = 3
Indoor unit operation by external contact	Short → Indoor unit On Open → Indoor unit Off	Short → Standby Open → Indoor unit Off	Short → Return to the last status of indoor unit Open → Indoor unit Off
Remote controller use	Short → Available Open → Available	Short → Available Open → Unavailable	Short → Available Open → Unavailable

Operation output

- Thermo off: Status where refrigerant is not flowing in either cooling/heating operation because desired temperature has been reached.

	DVM S series indoor unit	
Output signal	SEG 15 = 0 SEG 15 = 1	Thermo On/Off Operation On/Off
Output signal delay time	None	
Error signal		

PIM (Pulse Interface Module)

MIM-B16UN

Features

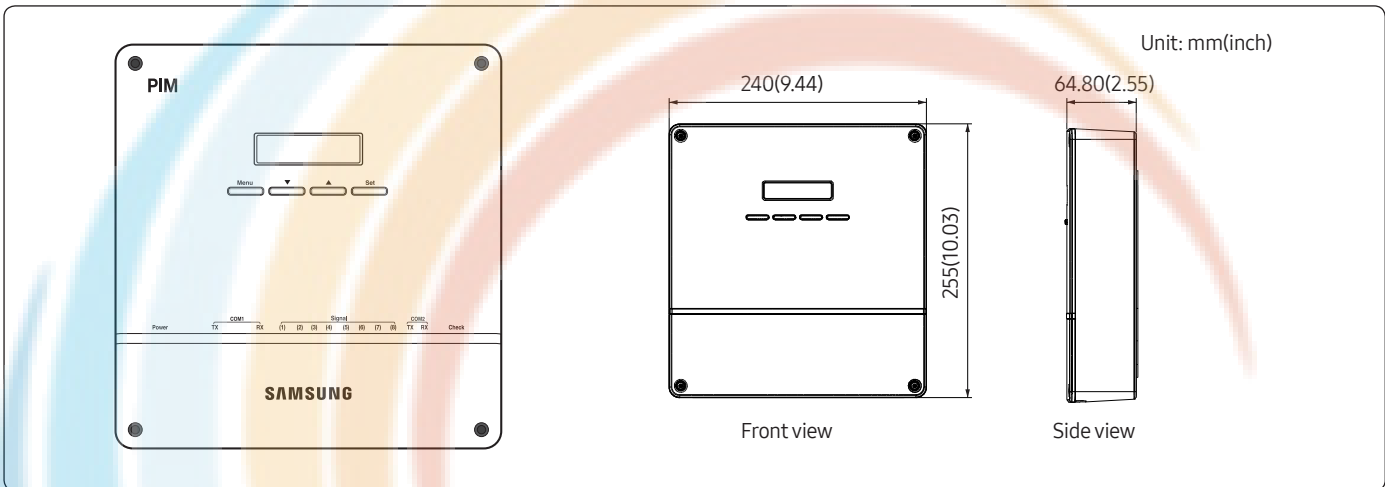

- Pulse output electricity meter interface unit (max. 8 meters)
- 8-channel energy consumption display in real time
- System configuration with button manipulation
- Various text messages in LCD
- Current communication state indication

Power supply (adapter)	Input: 100~240V AC, 50/60Hz, 1.0A Output: 12V DC, 3.0A
Operating temperature range	-10°C ~ 50°C (14°F~122°F)
Operating humidity range	10%RH~90%RH
Maximum wiring length	DMS2.5: 1000m (3280ft) Electricity meter: 200m (656ft)
Number of interfaces	Electricity meter: max. 8 units DMS2.5: 1 unit

PIM (Pulse Interface Module) › MIM-B16UN

Display and buttons

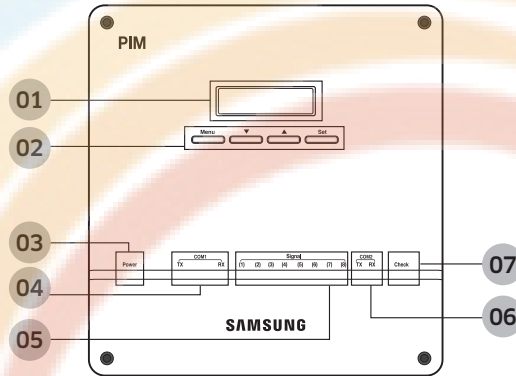

No.	Name	Description
01	LCD window	Information on current electricity readings, settings and operation state is displayed (16 character x 2 line LCD).
02	Menu button	Various menus are selected to monitor current electricity readings, to make configuration settings for electricity meters, and to check the error/settings.
03	Power (blue)	It's ON when power is supplied normally.
04	Communication (orange)	It blinks when communication between DMS2.5 and MIM-B16UN normally works.
05	Pulse input (orange)	Each of the 8 LEDs blinks whenever a pulse from an electricity meter is detected.
06	Communication (orange)	Reserved
07	Check	It's ON when errors occur in communication or pulse input from electricity meters.

PIM (Pulse Interface Module) > MIM-B16UN

Connectors

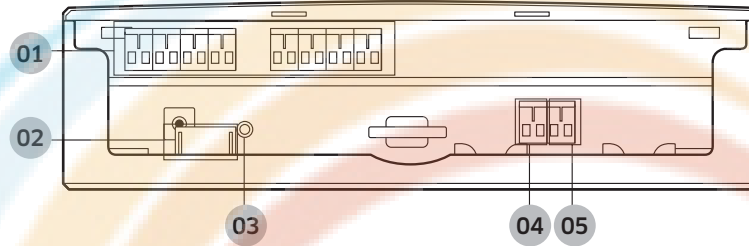

No.	Name	Description
01	Pulse input terminals	8 terminals are allocated to interface pulse-type electricity meters. Each terminal is seen with a dedicated address on DMS2.5.
02	Power input	Power supply via the power adapter.
03	Reset button	Press the button to reset the MIM-B16UN.
04	COM1	Connection terminal for RS485 communication with DMS2.5.
05	COM2	Reserved

Address & option switches

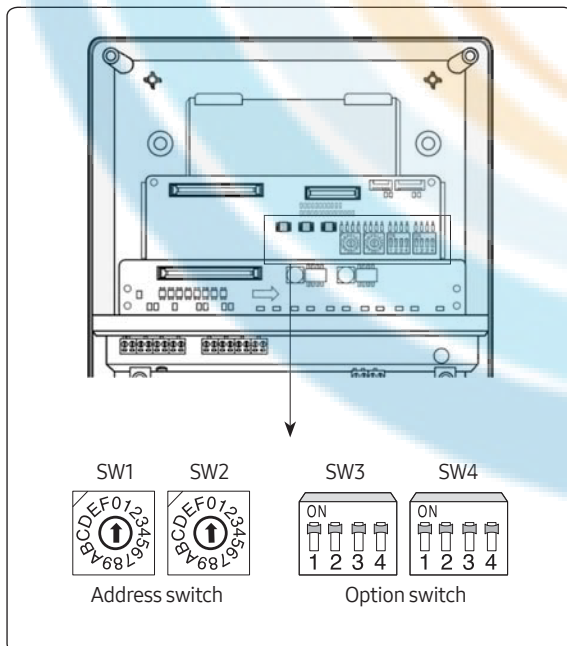

No.	Name	Description
01	SW1	No function
02	SW2	MIM-B16UN address switch. Address greater than 7 (8~F) is not recognized.
03	SW3	No function
04	SW4	No function

PIM (Pulse Interface Module) > MIM-B16UN

Specifications on electricity meter

- Current flow on output: Current-sinking
- Pulse rate :
 - Power meter: 1 ~10000 Wh/pulse (no decimal pulse rate allowed)
 - Gas meter: 0.001~10 m³/pulse
 - Water meter: 1 ~10000 liter/pulse (no decimal pulse rate allowed)
- Pulse width: 20 ~1000 ms with +/- 5% tolerance (no decimal pulse rate allowed)
- Time interval between pulses: Min.4ms
- Allowable current sinking: min. 15mA
- Withstanding voltage: min. 15V DC
- Interface circuitry: Electronic isolation circuitry recommended, no voltage output

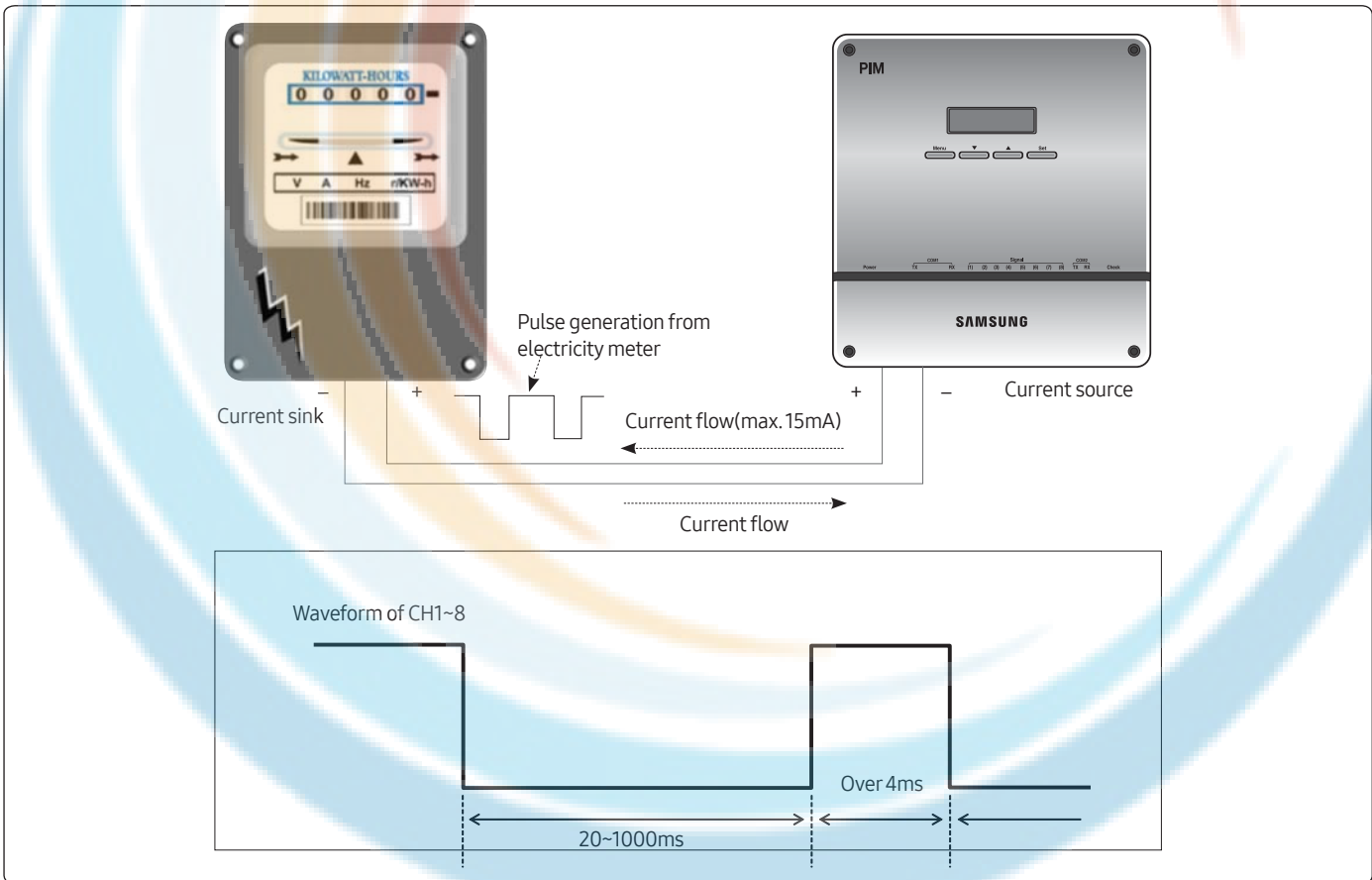

Note

- Interface circuitry of an electricity meter has to withstand min. 15mA and min. 15V DC, both of which are applied by MIM-B16UN.
- Even though MIM-B16UN interface circuitry is realized with electric isolation components, it's highly recommended that interface circuitry of an electricity meter be designed with isolation to ensure robustness from contact spike or electric interference during wiring.

PIM (Pulse Interface Module) > MIM-B16UN

Installation

MIM-B16UN must not be installed in a way that power to MIM-B16UN is off when one of the over-current circuit breakers is switched off. Power supply to MIM-B16UN must be off only when all the power supplies to refrigerant systems whose power consumptions are monitored by the MIM-B16UN are cut off. This is because every pulse from electricity meters of some alive refrigerant systems must be sensed normally even if power supplies to other refrigerant systems have troubles.

- Example 1)
When the circuit breaker, CM1 is switched off for some reason while the others are still on, pulses from the electricity meters, EM1, EM2 and EM3 are not calculated by MIM-B16UN, whose power is off by the CM1. This installation could lead to errors in electricity billing function when power interruption in local areas occurs.

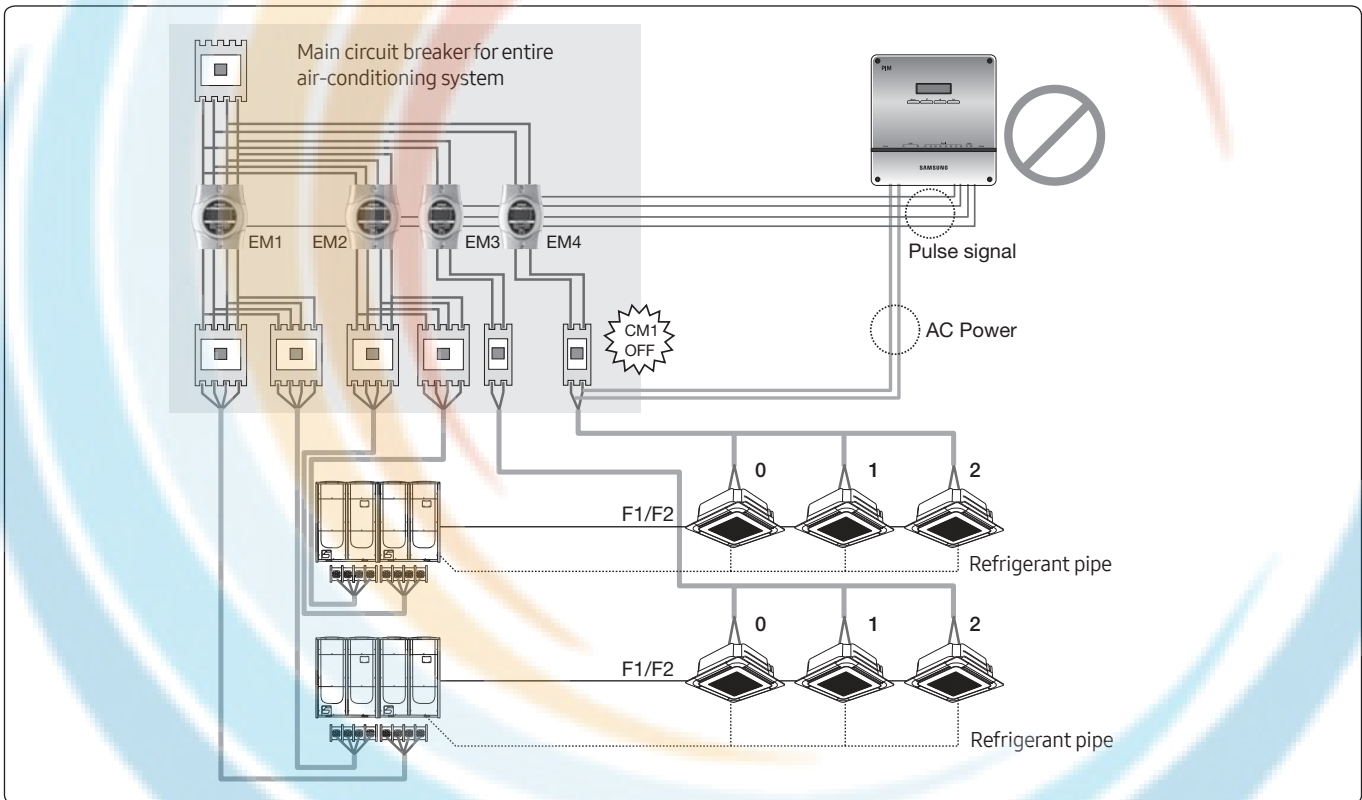

PIM (Pulse Interface Module) > MIM-B16UN

- Example 2)
Even when the circuit breaker, CM1 is switched off while the others are on, pulses from the electricity meters, EM1, EM2 and EM3 are still calculated by MIM-B16UN, whose power is not interrupted by CM1.

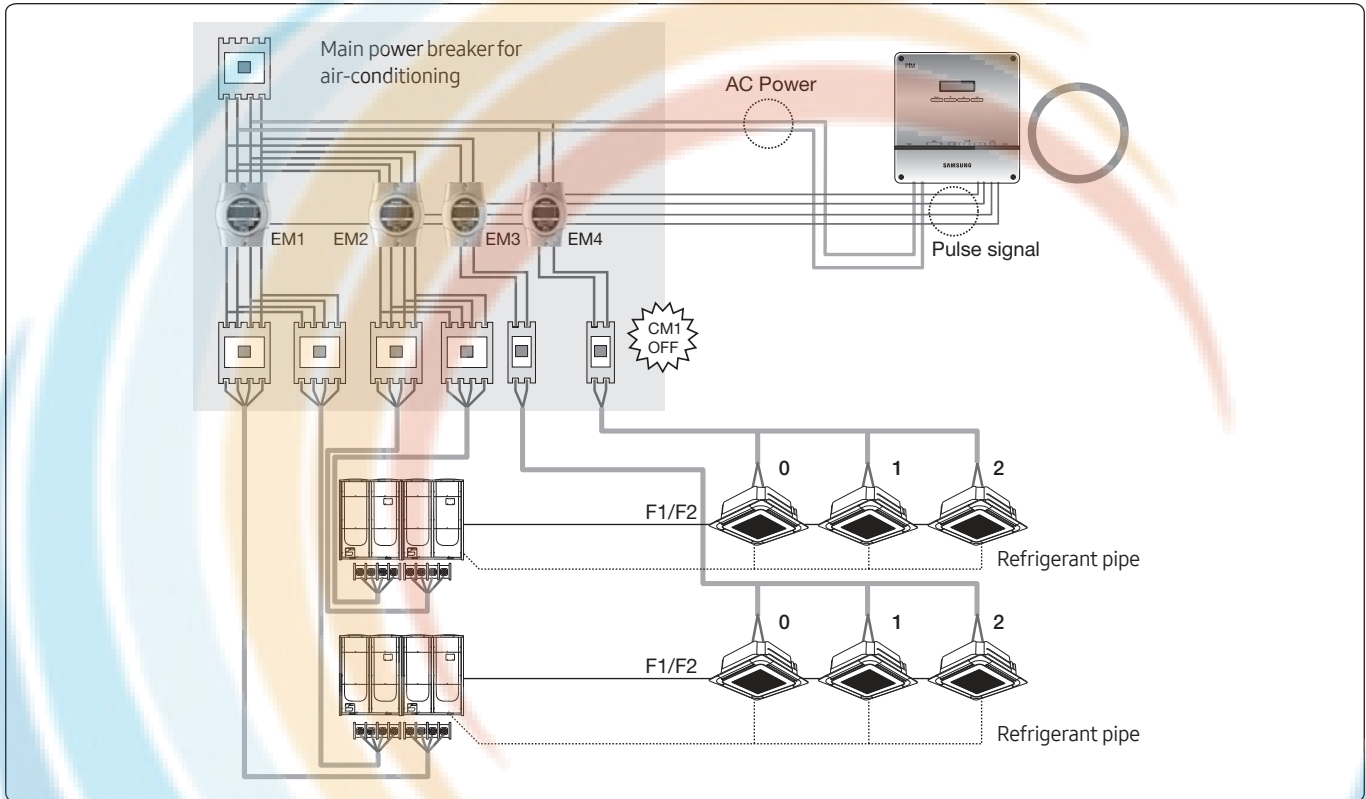

PIM (Pulse Interface Module) > MIM-B16UN

Wiring

Wiring to electricity meter

Attention must be paid to make polarized connection between an electricity meter and MIM-B16UN with correct specifications on wires.

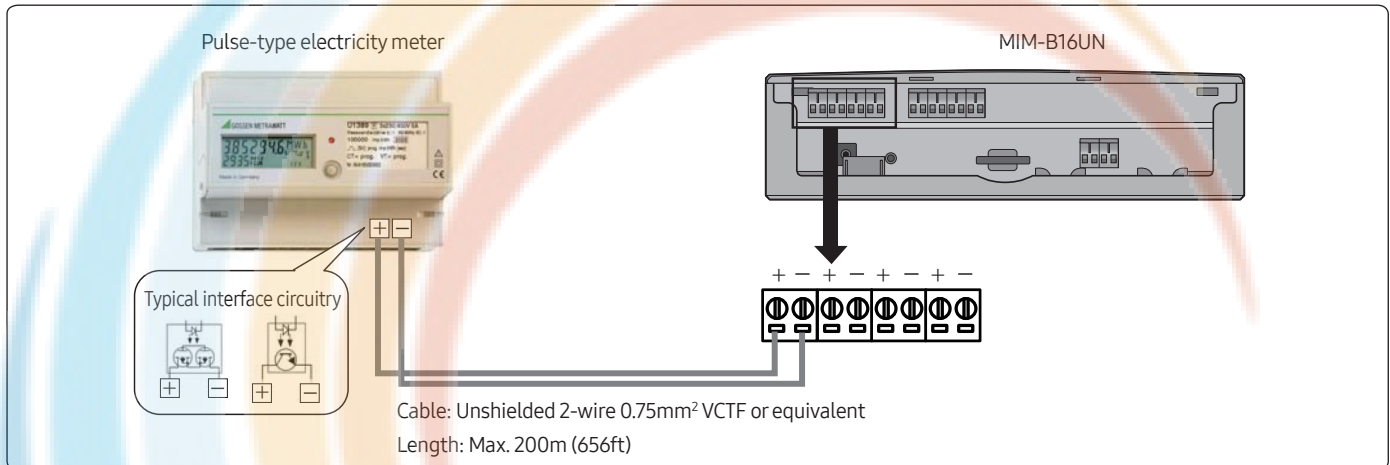

Wiring to DMS2.5

Make sure that communication cable is wired between DMS2.5 and MIM-B16UN with the right polarity.

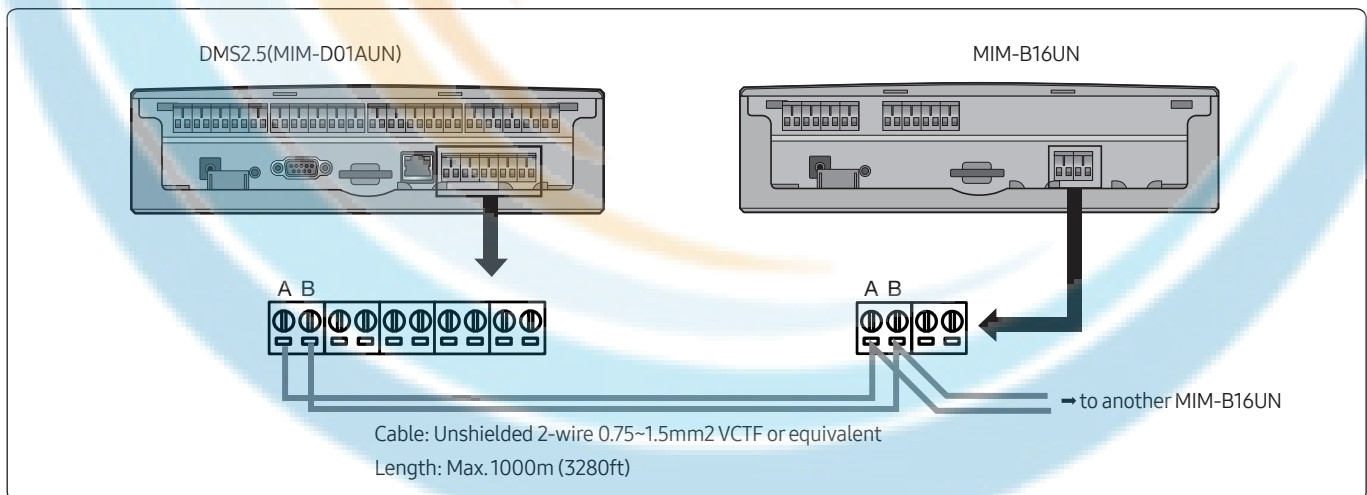

⚠ Caution

- MIM-B16UN can be connected with outdoor units/controllers to same channel of DMS2.5.
Ex) DMS2.5 CH1: PIM + Outdoor unit (O)/PIM + Touch controller (O)
– Outdoor unit or Controller should be new communication applied products.

PIM (Pulse Interface Module) › MIM-B16UN

Address assignment

Each of the electricity meters is assigned with the dedicated address depending on MIM-B16UN address setting and the position of the pulse input terminals.

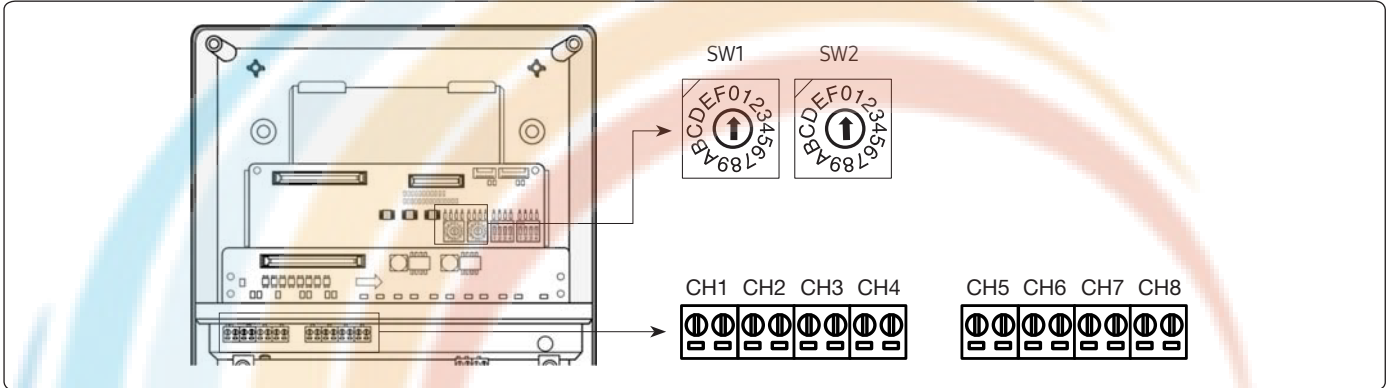

Electricity meter address assignment table





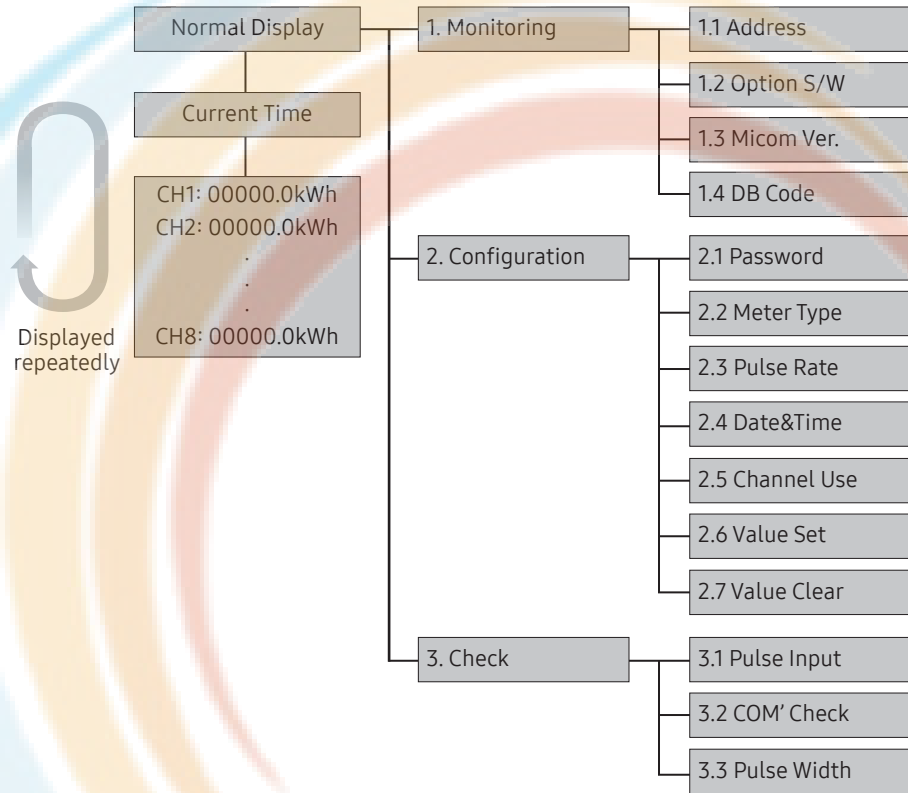

SW2	Pulse input terminal							
	CH1	CH2	CH3	CH4	CH5	CH6	CH7	CH8
0	16.01	16.02	16.03	16.04	16.05	16.06	16.07	16.08
1	17.01	17.02	17.03	17.04	17.05	17.06	17.07	17.08
2	18.01	18.02	18.03	18.04	18.05	18.06	18.07	18.08
3	19.01	19.02	19.03	19.04	19.05	19.06	19.07	19.08
4	20.01	20.02	20.03	20.04	20.05	20.06	20.07	20.08
5	21.01	21.02	21.03	21.04	21.05	21.06	21.07	21.08
6	22.01	22.02	22.03	22.04	22.05	22.06	22.07	22.08
7	23.01	23.02	23.03	23.04	23.05	23.06	23.07	23.08
8~15	Not recognized							

PIM (Pulse Interface Module) > MIM-B16UN

MIM-B16UN menu structure

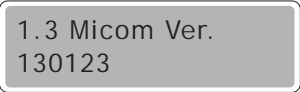

PIM (Pulse Interface Module) > MIM-B16UN

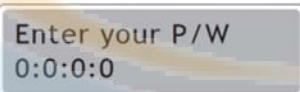
Main menu	Sub menu	Description										
Monitoring	PIM Address	<p>The MIM-B16UN address is displayed with the physical address SW2 added by 30H on the LCD window.</p> <p>Ex)</p> <table border="1"> <tr> <td>LCD</td> <td>SW2 setting</td> </tr> <tr> <td>30H</td> <td>0</td> </tr> <tr> <td>31H</td> <td>1</td> </tr> <tr> <td>...</td> <td>...</td> </tr> <tr> <td>37H</td> <td>7</td> </tr> </table>  	LCD	SW2 setting	30H	0	31H	1	37H	7
	LCD	SW2 setting										
	30H	0										
	31H	1										
...	...											
37H	7											
Option SW	<p>Option switch setting to ON is displayed with the position number at the corresponding positions while setting to OFF is shown with the mark 'X'.</p> <p>Ex)</p>   <p>Example display: 1X</p> <ul style="list-style-type: none"> • Option switch 1: On • Option switch 2: Off 											
Micom version	<p>It displays PIM software version.</p> <p>Ex)</p> 											
DB Code	<p>It displays PIM software DB code.</p> <p>Ex)</p> 											
Configuration	Password	<p>The password, which is asked to enter to change the configuration setting, is used to prevent unauthorized persons from accessing MIM-B16UN. Factory setting is '0000'.</p> <p>Ex)</p> 										
	Meter type	<p>You can select each channel's meter type.</p> <ul style="list-style-type: none"> • Default value: Power Meter • Type: Power Meter, Gas meter, Water Meter 										
	Pulse Width	<p>You can set pulse rate of meter which connected to each channel. [Range]</p> <p>Power meter: 1 ~10000 Wh/pulse (No decimal pulse rate allowed)</p> <p>Gas meter: 0.001~10 m³/pulse</p> <p>Water meter: 1 ~ 10000 liter/pulse (No decimal pulse rate allowed)</p>										
	Date & time	<p>You can set current date and time.</p>										
	Channel use	<p>You can set Enable/Disable state of each channel.</p> <p>If you set "Disable", then PIM doesn't display meter value of the disabled channel.</p>										

PIM (Pulse Interface Module) > MIM-B16UN

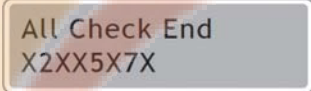
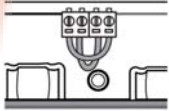
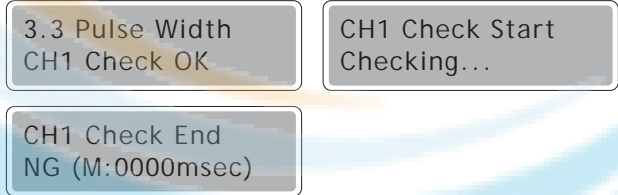
Main menu	Sub menu	Description
Configuration	Value set	Initial meter value must be set as a starting point for each of the enabled interface channels.
	Value clear	Each or all the initial meter values are cleared when selected.
Check	Pulse Input	<p>When pulse input is detected during the test period, the channel numbers are displayed. Otherwise, the character 'X' is displayed on the corresponding channel position.</p> 
	COM Check	<p>Make a loopback connection between COM1 and COM2 to check if the DMS2.5 communication channel is working or not. Care must be taken for the connection polarity.</p>  <p>When the COM1 communication channel is normal, the message 'OK' is displayed on the LCD window.</p>
	Pulse Width	<p>It checks if the pulse width values of actually connected meter are valid or not.</p> <ul style="list-style-type: none"> • OK: When the pulse is valid (pulse is valid when high pulse is between 20 ~ 1000msec), OK (M:####msec) will be displayed. #### represents the duration of the high pulse. • NG: When the pulse is invalid (pulse is valid when high pulse is between 20 ~ 1000msec), or when there is no pulse inputs for 10 seconds), NG (M: 0000msec) will be displayed. <p>– PIM does not calculate the energy consumption during the checking process. The calculation will start after the check and returning to the upper menu.</p> 

PIM (Pulse Interface Module) › MIM-B16UN

Setting parameters on DMS2.5 (MIM-D01AUN)

The following parameters for MIM-B16UN can be also set and monitored on DMS2.5 (MIM-D01AUN)

- Meter value, Meter type/pulse rate, Channel status, Time setting, PIM password

▶ [Tracking result page --> PIM “Setting”]

CH0	PIM	<input type="button" value="Setting"/>	16	<input type="text" value="16"/>
CH0	PIM	<input type="button" value="Setting"/>	17	<input type="text" value="17"/>



Note

- DMS2.5 setting for MIM-B16UN parameters

Error code

Error code	Description
E613	Error which occurs when there is no communication between DMS and PIM/SIM for 15 minutes.
E632	<ul style="list-style-type: none"> • Error which occurs when the pulse was input differently from the PIM setting. • (If the pulse was inputted at the value outside of 10 ms ~ 1500 ms range for more than 15 times or when high pulse was inputted for over 3 minutes)
E654	Memory Read/Write error.
E108	Error which occurs when same address was assigned to different devices.

Interface module

MIM-N01

Features

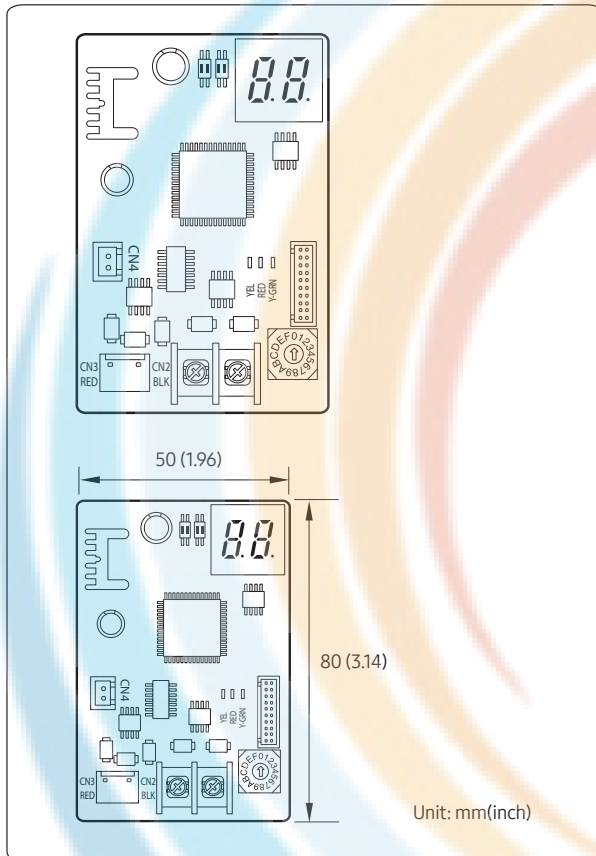

- Communication interface module between outdoor units and the upper level controller which has different communication type
- Connect 1 interface module to 1 outdoor unit
- Individual control - Maximum 48 indoor units
- Group control - Maximum 16 groups
- Detecting communication type automatically: Judge the communication type of upper level controller according to communication type of the outdoor unit
- Supported communication type
 - Conventional communication outdoor unit ↔ New communication upper level controller
 - New communication outdoor unit ↔ Conventional communication upper level controller

⚠ Caution

- This interface module does not support connection between Conventional communication outdoor unit ↔ Conventional communication upper level controller/New communication outdoor unit ↔ New communication upper level controller

Product specification

Power Supply	DC12V
Power Consumption	2.4 W
Operating Temperature range	-10 °C~50 °C (14°F~122°F)
Operating Humidity range	10%RH~90%RH
Communication	RS485 x 2
Max.Communication Length	1000 M (3280 ft)
Maximum number of connection	<ol style="list-style-type: none"> 1. New communication outdoor unit ↔ Conventional communication upper level controller F1/F2: 1 outdoor unit R1/R2: 1 upper level controller 2. Conventional communication outdoor unit ↔ New communication upper level controller F1/F2: 1 outdoor unit R1/R2: Total up to 16 upper level controllers (Only1 DMS 2.5, BACnet/LonWorks Gateway connection is allowed)

Interface module > MIM-N01

Compatible Models

New communication outdoor unit ↔ Conventional communication upper level controller

Outdoor unit	AM*****X*****
Upper level controller	<ol style="list-style-type: none"> 1 OnOff controller: MCM-A202D 2 DMS2: MIM-D00A 3 BACnet Gateway: MIM-B17 4 LonWorks Gateway: MM-B18 5 S-NET mini: MST-S3WU

- Function controller and S-NET 2 Plus are not supported.
 - New communication Outdoor unit + MIM-N01 + MCM-A202D + Function controller (X)
 - New communication Outdoor unit+ MIM-N01 + MCM-A202D + S-NET 2 Plus (X)

Conventional communication outdoor unit ↔ New communication upper level controller

Outdoor unit	DVM Plus 4, 3, 2, CAC, FJM
Upper level controller	<ol style="list-style-type: none"> 1 OnOff Controller: MCM-A202DUN 2 DMS2.5: MIM-D01AUN 3 BACnet gateway: MIM-B17BUN 4 LonWorks gateway: MIM-B18BUN 5 Touch centralized controller: MCM-A300UN 6 Wi-Fi kit : MIM-H03UN

Interface module > MIM-N01

Description of parts

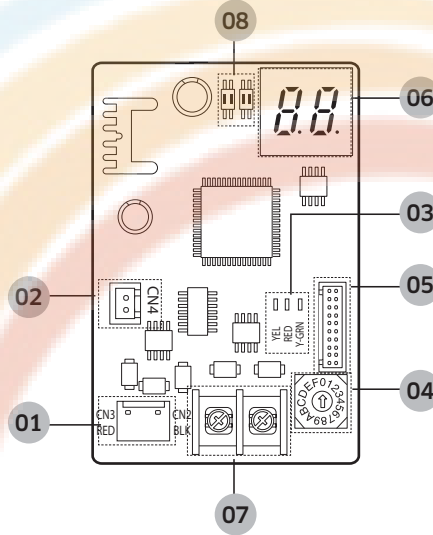

No.	Name	Description
01	F1/F2 communication connector	Communication connector that connects to outdoor unit/F1/F2
02	Power connector	DC 12V
03	Communication LED	Communication indicator LED <ul style="list-style-type: none"> • Left LED 3: No function • Middle LED 1: Blinks during it communicates with upper level controller • Right LED 2: Blinks during it communicates with outdoor unit and indoor unit
04	Address setting switch	Sets the address of interface module
05	Software update connector	Using this connector, Interface module software can be updated
06	7-segment	Displays the communication status between interface module and outdoor unit
07	Upper level controller communication channel	Communication connection channel to upper level controller R1/R2

Interface module › MIM-N01

No.	Name	Description
-----	------	-------------

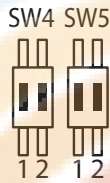

08 DIP switch

SW4	Description
1	OFF (Automatic address setting, switch must be down) ON (Manual address setting, switch must be up) <ul style="list-style-type: none"> This function is only applicable when new communication upper level controller is connected.
2	OFF (Set temperature in Celsius, switch must be down) ON (Set temperature in Fahrenheit, switch must be up)
SW5	Description
1	OFF (Disable downloading, switch must be down) ON (Enable downloading, switch must be up) <ul style="list-style-type: none"> Switch must be set to OFF when downloading is complete.
2	No function

Note

- When connecting to the conventional communication controller, address must be set manually regardless to the SW4-1 setting. When setting the address manually, make sure to set the address that is not assigned to other device already.
- When connecting to the new communication controller, SW4-1 must be ON to set the address manually, and make sure to set the address that is not assigned to other compatible interface module or outdoor units.

Interface module > MIM-N01

Connection diagram

New communication outdoor unit ↔ Conventional communication upper level controller

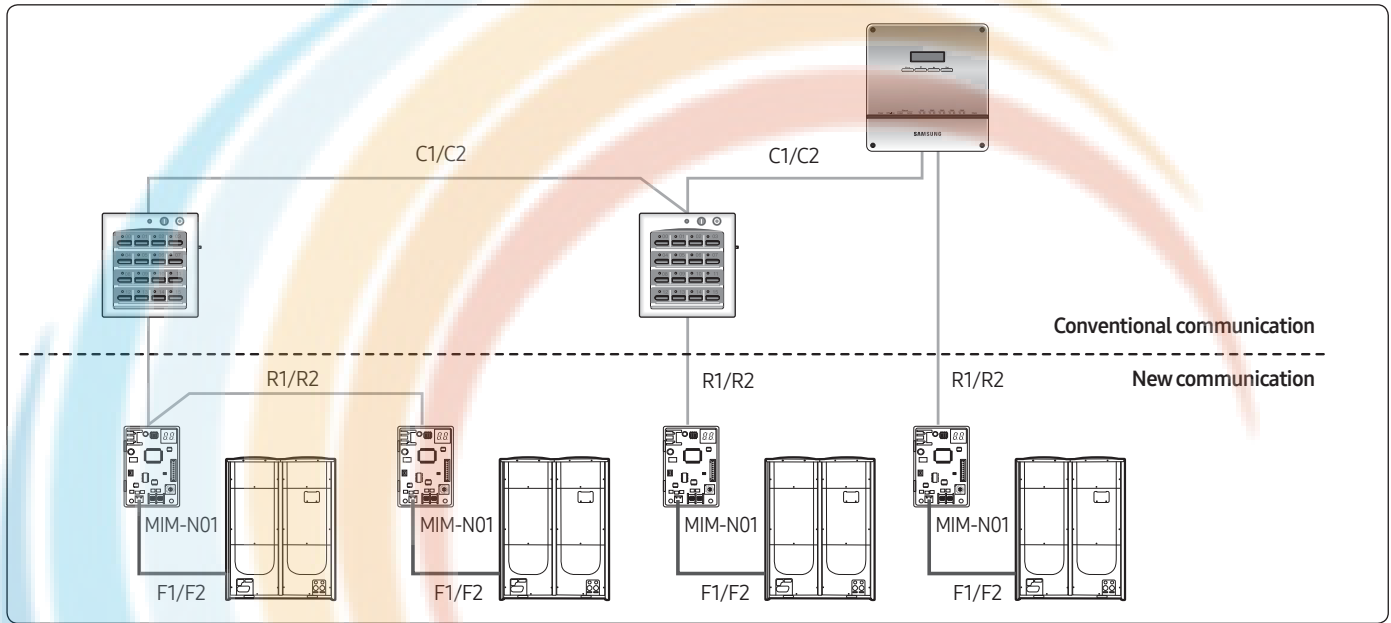

Conventional communication outdoor unit ↔ New communication upper level controller

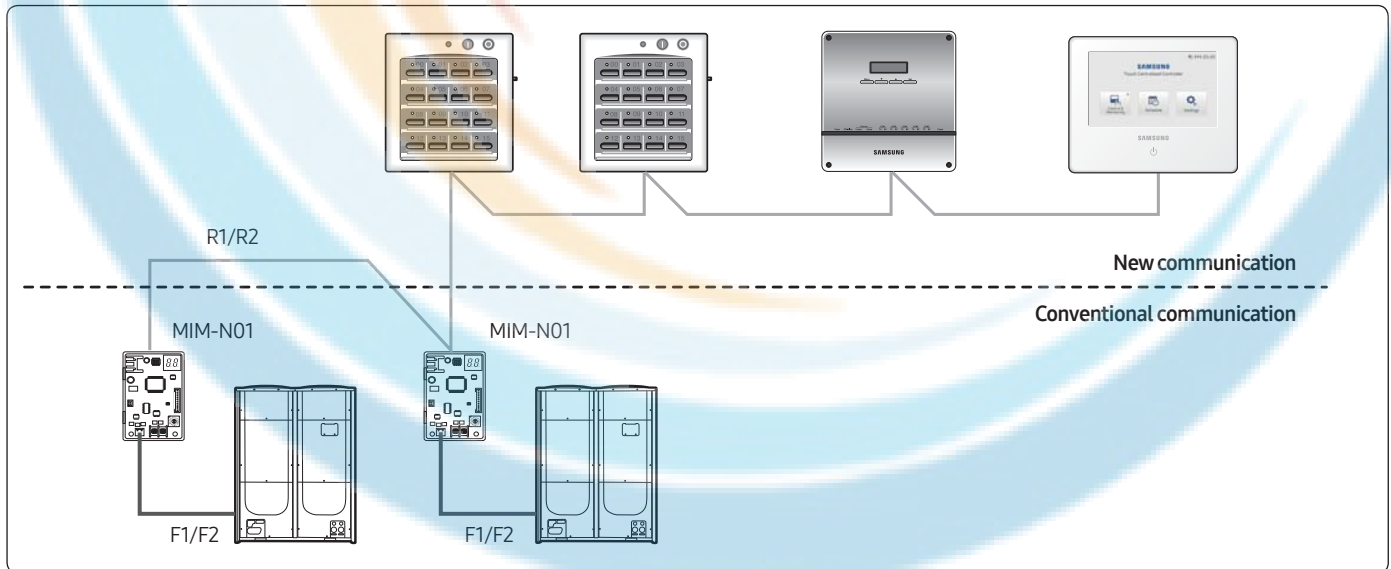

Connection

Connecting with OnOff controller

- Conventional communication outdoor unit ↔ New communication OnOff controller (MCM-A202DUN)
- New communication outdoor unit ↔ Conventional communication OnOff controller (MCM-A202D)

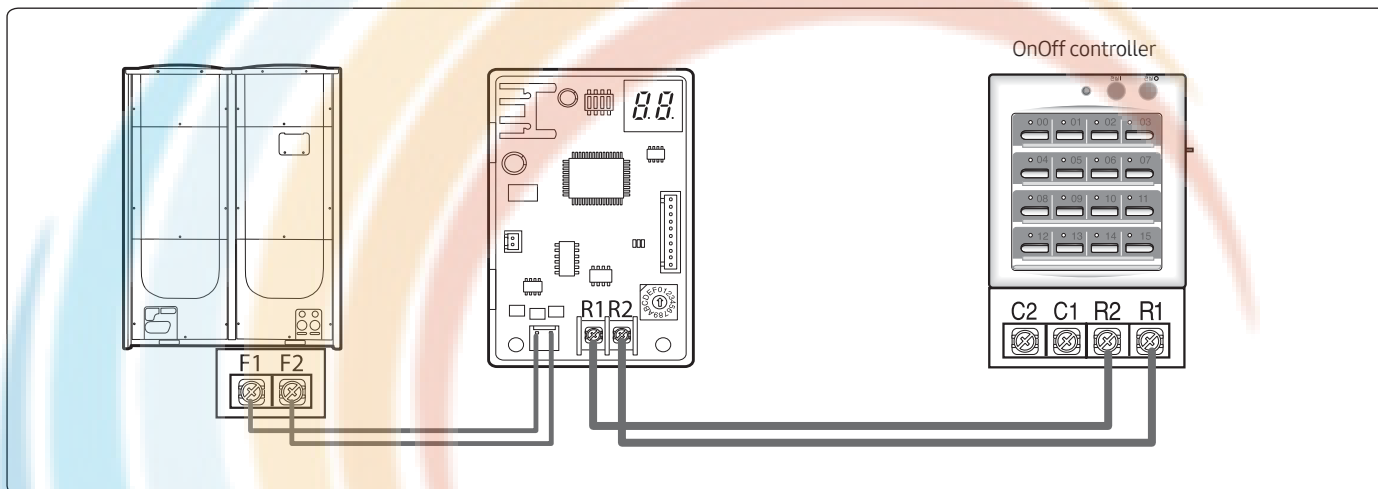

Interface module > MIM-N01

Connecting to Touch centralized controller

- Conventional communication outdoor unit ↔ New communication Touch centralized controller (MCM-A300UN)

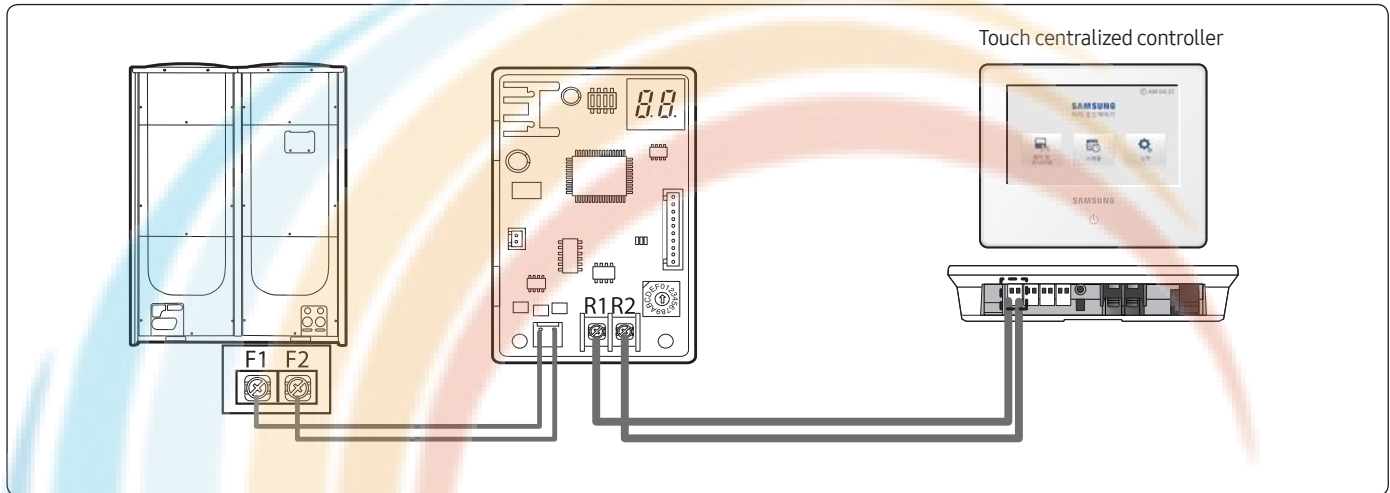

Connecting to DMS/BACnet GW/LonWorks GW

- Conventional communication outdoor unit ↔ New communication DMS2.5 (MIM-D01AUN)/BACnet GW (MIM-B17BUN)/LonWorks GW (MIM-B18BUN)
- New communication outdoor unit ↔ Conventional communication DMS2 (MIM-D00A)/BACnet GW (MIM-B17)/LonWorks GW (MIM-B18)

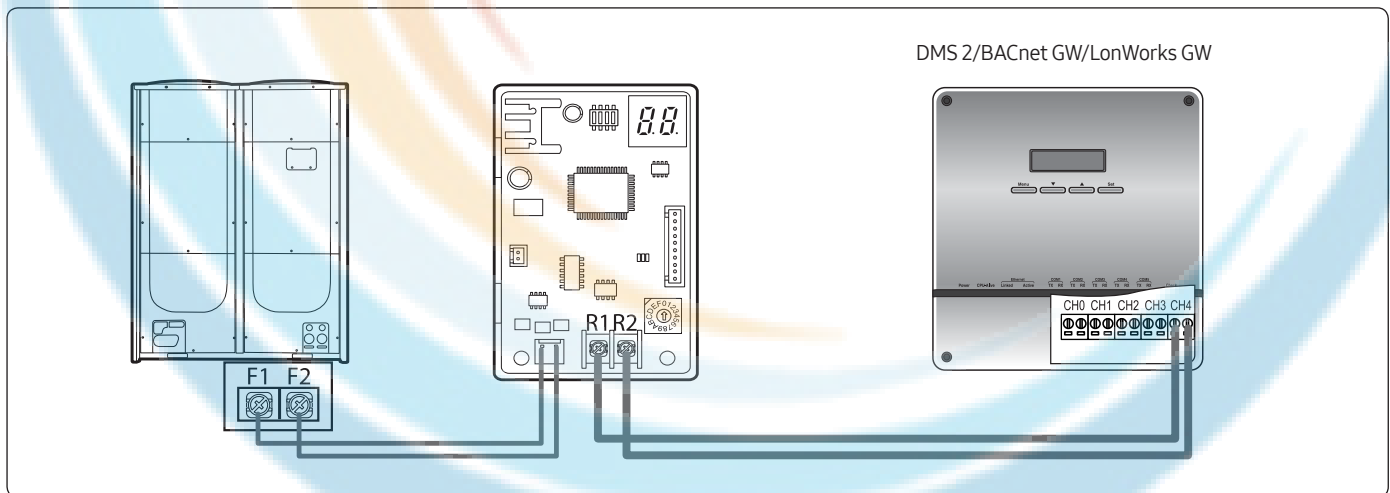

Note

- When connecting AM****X*****, AC****X***** outdoor unit and new communication controller, you don't have to connect them with MIM-N01.
- When connecting Conventional communication outdoor unit and controller (ex. MCM-A202D), MIM-B13D or MIM-B13E must be used.

Interface module > MIM-N01

Display

Checking the operation

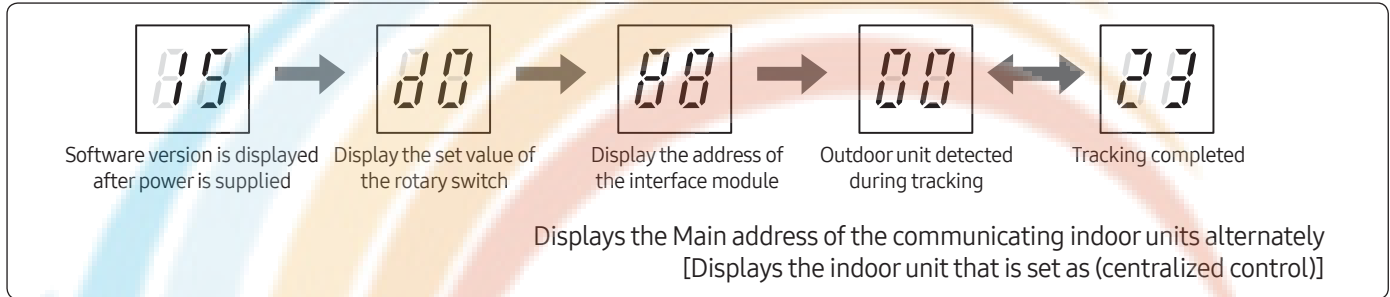

Error display

- Communication error between outdoor unit and the interface module

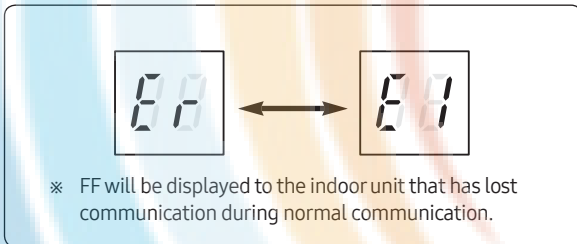

- Communication error between upper level controller and the interface module after tracking has been completed

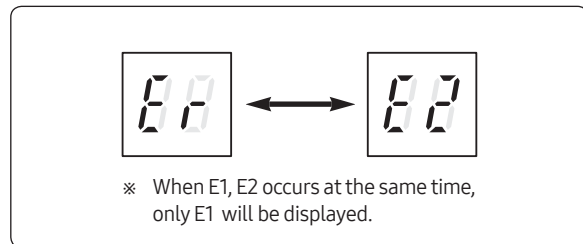

- Interface module tracking failure

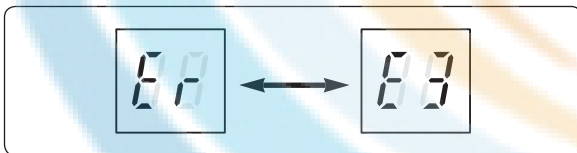

- When problem occurs on EEPROM

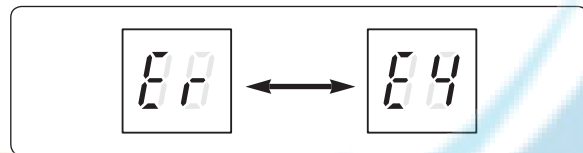

- Communication error between conventional communication outdoor unit ↔ New communication upper level controller after tracking has been completed

- It will be displayed after failing 80 times of communication trial after interface module has started tracking (approximately 3 minutes)

- Communication error between New communication outdoor unit ↔ Conventional communication upper level controller after tracking has been completed

- It will be displayed after failing the tracking process over 10 minutes from the interface module has started tracking.

- When same address was assigned to more than one interface module (Only detected when new communication upper level controller is connected to conventional communication outdoor unit)

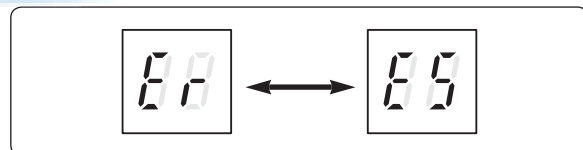

■ Error display table

Error	Display	Error Code	Display on new communication upper level controller	Display on Conventional communication upper level controller
EEPROM	Er-E4	E654	E654	-
Overlapped address	Er-E5	E108	E108	-
Tracking failure	Er-E3	E604	E201	-
Indoor unit communication error	Er-E1	E615	E201 or E101	E615
Outdoor unit communication error	Er-E1	E616	E202	E616
Upper level controller communication error (Conventional type)	Er-E2	-	-	-

FCU interface module

MIM-F10N

Features

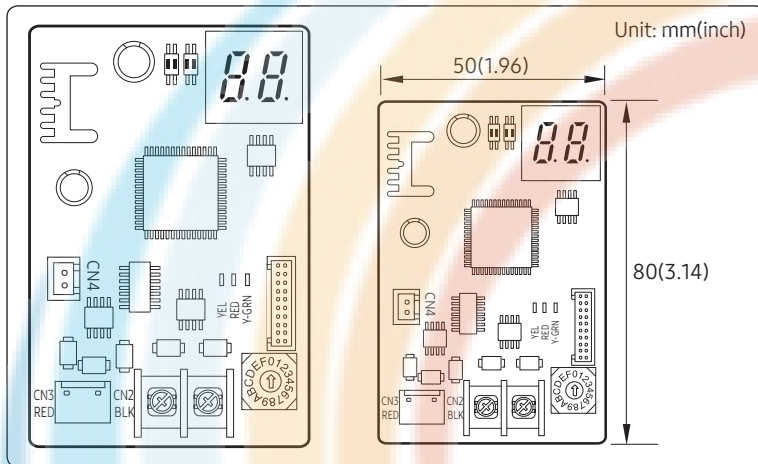

- Communication interface module between FCU KIT and upper level controller.
- Connect 1 FCU interface module to Max. 16 FCU KITS.
- Supports FCU KIT only

Product specification

Power Supply	DC 12V
Power Consumption	1W
Operating Temperature range	-10 °C~50 °C (14 °F~122 °F)
Operating Humidity range	10%RH~90%RH
Communication	RS485 x 2
Maximum Communication Length	1000 M (3280 ft)
Maximum number of connection	<ul style="list-style-type: none"> • F1/F2: 16 FCU KITS • R1/R2: Total up to 16 upper level controllers (Only 1 DMS 2.5, BACnet GW/LonWorks GW connection is allowed)

Compatible Models

FCU KIT	MIM-F00N
Upper level controller	<ul style="list-style-type: none"> • DMS2.5: MIM-D01AUN • BACnet GW: MIM-B17BUN • LonWorks GW: MIM-B18BUN • Touch centralized controller: MCM-A300UN

FCU interface module > MIM-F10N

Description of parts

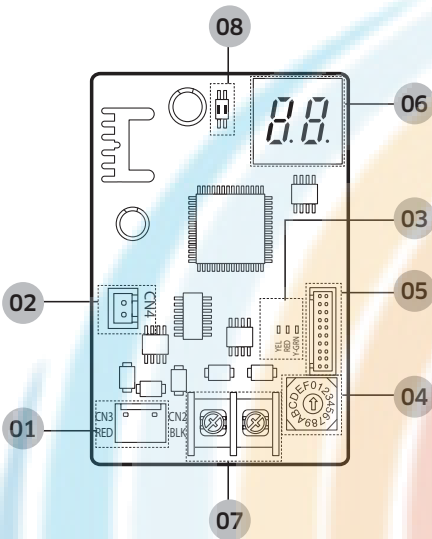

No.	Name	Description
01	F1/F2 communication connector	Communication terminal that connects to F1/F2 of FCU KIT
02	Power connector	DC 12V
03	Communication LED	Communication indicator LED <ul style="list-style-type: none"> • Left LED3: No function • Middle RED: Blinks during it communicates with upper level controller • Right Y-GRN: Blinks during it communicates with FCU KIT
04	Address setting switch	Sets the address of interface module
05	Software update connector	Using this connector, interface module software can be updates
06	7-segment	Displays the communication status between interface module and FCU KIT
07	Upper level controller communication channel	Communication terminal to upper level controller R1/R2



08 DIP switch

SW4		
	1	2
ON	Manual address	No function
OFF	Automatic address	

Connection diagram

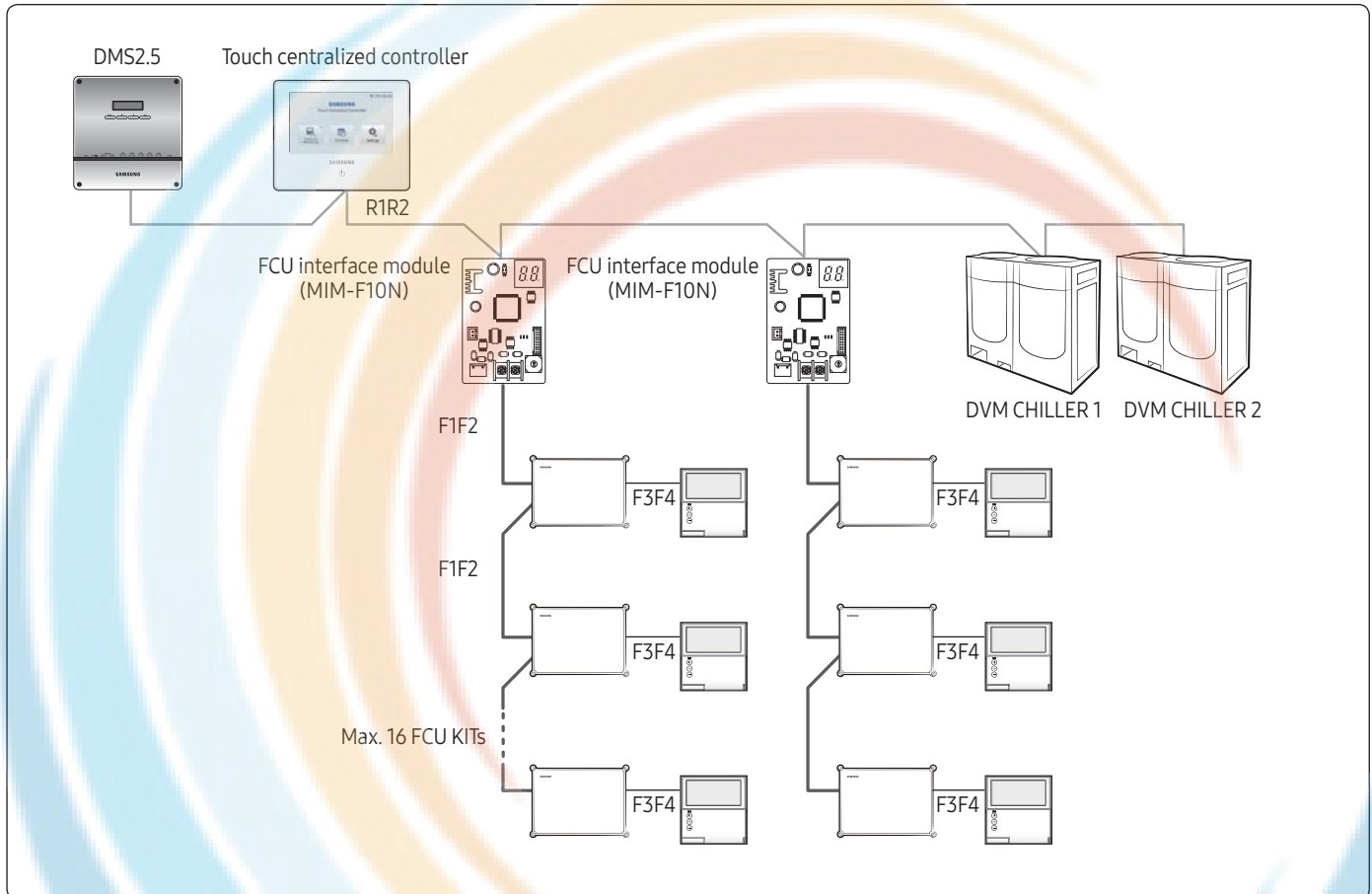

Connection

Connecting with Touch centralized controller

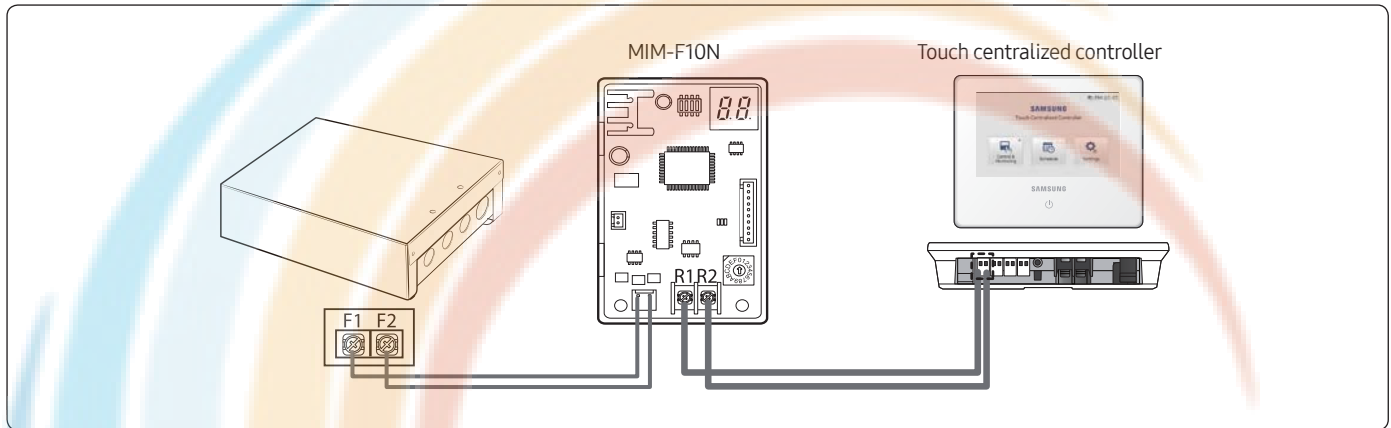

Connecting with with DMS2.5/BACnet GW/LonWorks GW

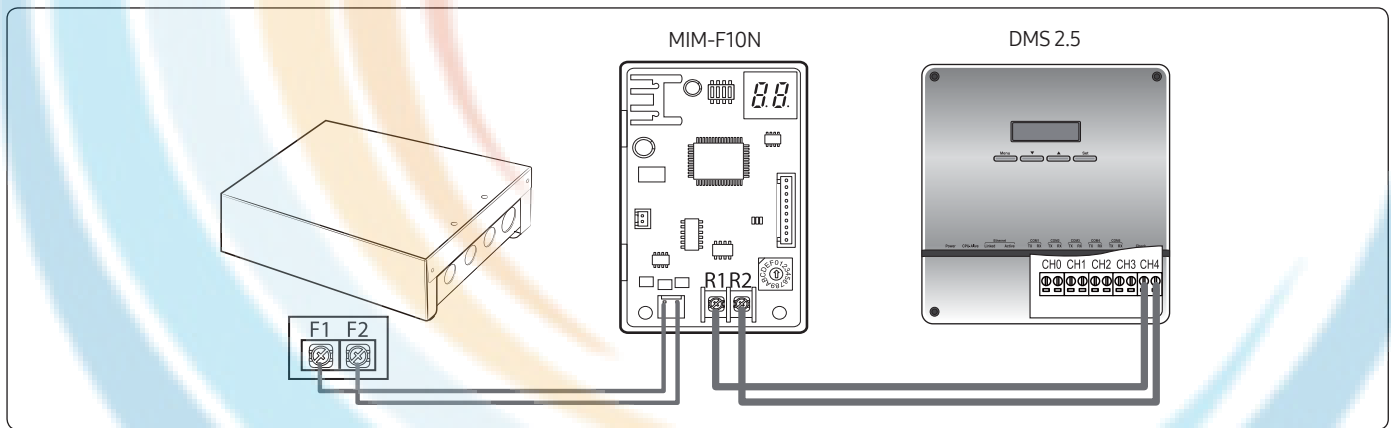

Display

- 1 When initializing power supply, **BB** will be indicated after indicating the program cord.
- 2 After receiving valid communication more than once, **BB** will be indicated.
- 3 When the communication is normal, the MAIN ADDRESS of the FCU KIT that can be controlled by the FCU interface module is indicated in order.
- 4 When there is no communication between the FCU KIT and the FCU interface module for more than 3 minutes, **EP ↔ E1** will be indicated alternately.
- 5 When the FCU interface module tracking is not complete, **EP ↔ E3** will be indicated alternately.
- 6 When there's error on EEPROM of the FCU interface module, **EP ↔ E4** will be indicated alternately.
- 7 When same address was set to multiple FCU interface modules, **EP ↔ E5** will be indicated alternately.
- 8 When more than 16 FCU KITs are installed, **EP ↔ E6** will be indicated alternately.
- 9 When FCU KIT and indoor units are installed together, **EP ↔ E8** will be indicated alternately.



Chapter
05

Installation / Test run Solution

S-Converter

MIM-C02N..... 265

S-Converter

MIM-C02N

Features

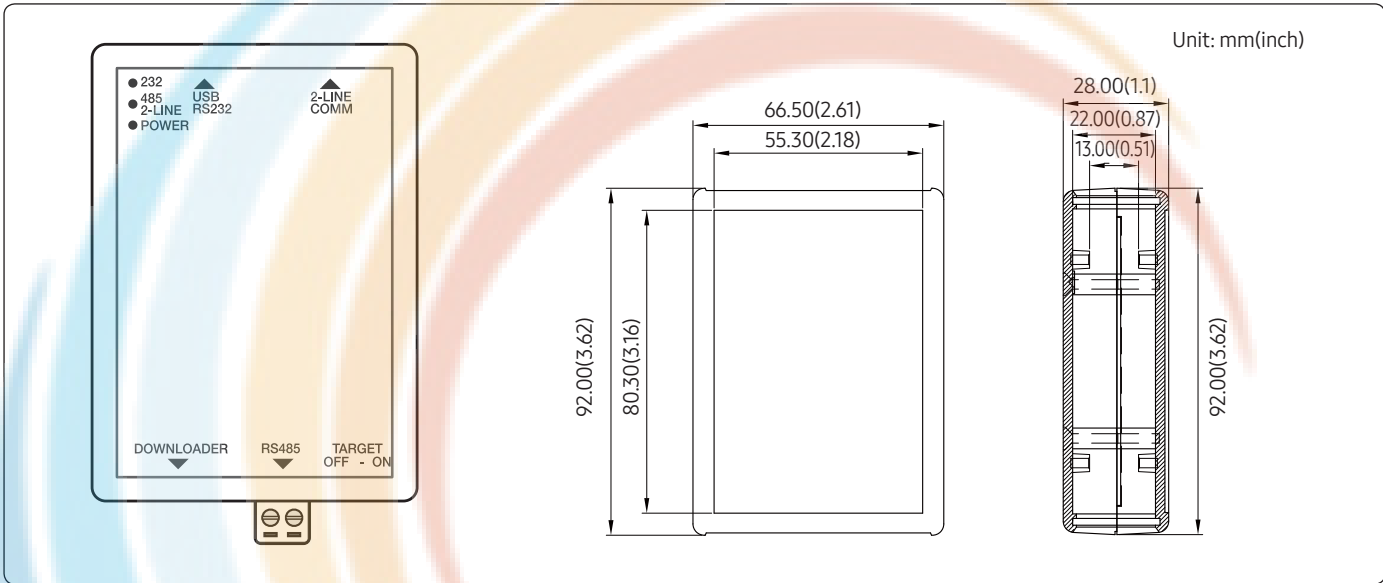

- Communication converting module to connect Samsung system air conditioner to a PC.
 - Main purpose for use
 - To connect with test run program
- [Test run program]
- S-NET Pro: Conventional communication
 - S-NET Pro2: New communication

Product specification

Power supply			DC 5V, below 500mA
Power consumption			Below 3W
Operating temperature range			0°C~40°C (32°F~104°F)
Operating humidity range			0%RH~90%RH
Communication	RS485	Port Q'ty	1
Maximum length of connection	RS485	m(ft)	1000 (3280)

S-Converter > MIM-C02N

Description of parts

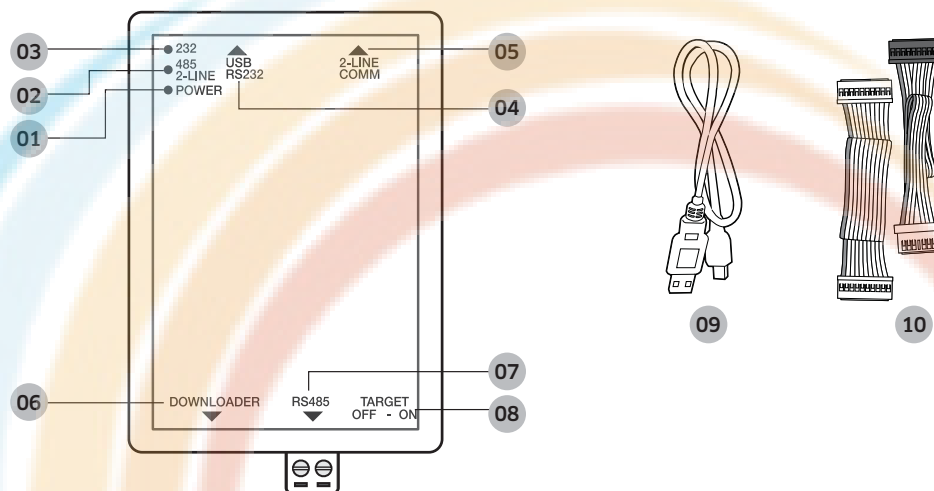

No.	Name	Description
01	Power LED	Display power status
02	485 communication/ 2 line communication LED	Displays communication status when outdoor unit 2 line remote controller is connected
03	232 LED	Displays communication status with the PC
04	USB-RS232 connection terminal	Connection terminal for communication with the PC
05	2 line communication connection terminal	Only applies to new communication indoor unit 2 line communication connection terminal between indoor unit - wired remote controller (For R&D testing)
06	Downloader connection terminal	PBA download connection terminal
07	RS485 communication connection terminal	Connection cable for connecting with indoor/outdoor unit's F1, F2 communication terminal
08	TARGET OFF – ON button	Only used when S-converter is used as SW downloader for the product <ul style="list-style-type: none"> If the S-Converter supplies the power through the PBA of the product that will download the SW, this button resets the power that was supplied through the S-Converter
09	USB-to-232 cable	Cable that connects S-Converter and PC
10	SW downloader cable	Only used when S-converter is used as SW downloader for the product <ul style="list-style-type: none"> Connect S-Converter (20 Pin) and the downloader terminal (10 Pin, 7 Pin) of the product's PCB

Connection diagram

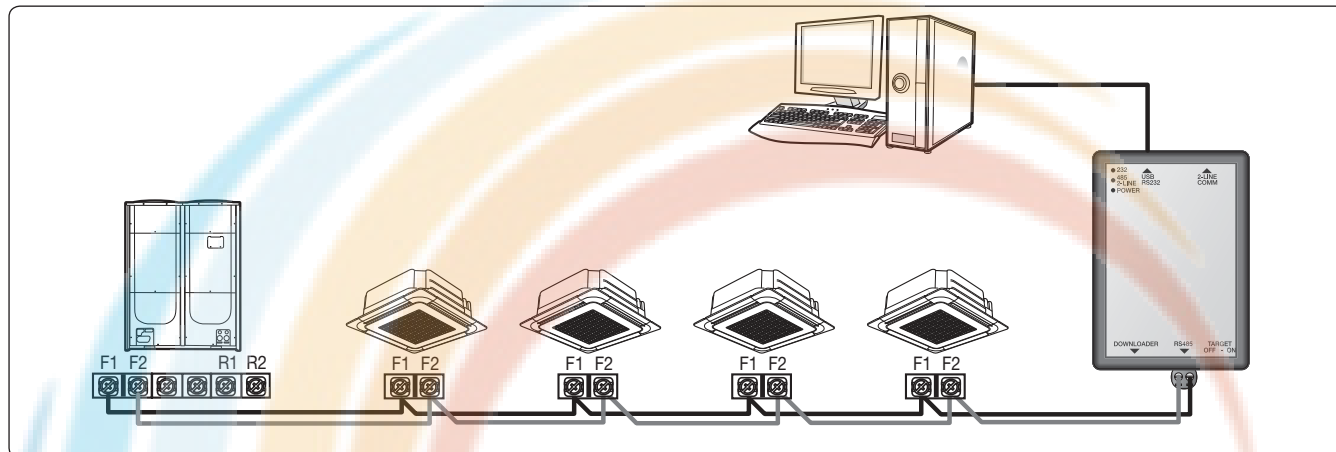

Connecting

Connecting with outdoor unit

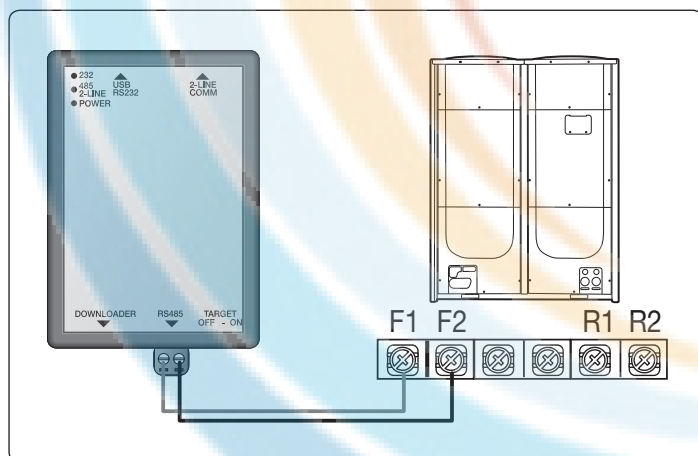

Connecting with PC

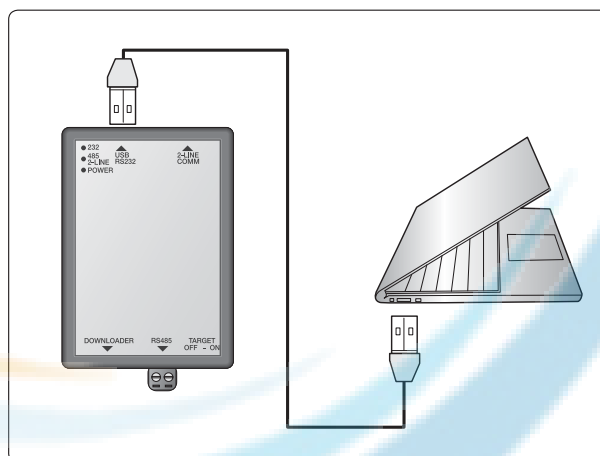

Display

POWER LED

- When connected to Conventional communication outdoor unit - LED blinks
- When connected to new communication outdoor unit - LED is on

232 LED

- LED blinks every time control signal is transmitted from the Test run program
- If the LED doesn't blink even though the test run program sends control command, check if the program is appropriate for the communication type (Conventional communication/new communication)

485/2-LINE LED

- LED blinks when the data is being transmitted from the 485 or 2-line communication device
- 485 communication cable - outdoor unit connection (Connects test run program)
- 2-line communication device - wired remote controller connection (connects program for the developer)
- If the LED doesn't turn on, check if the communication cable is disconnected/short or check if the device is appropriate for the communication type (Conventional communication/new communication)

Chapter **06**

Others

External Room Sensor

MRW-TA.....270

Operation mode selection switch

MCM-C200U272

MTFC (Multi Tenant Function Controller)

MCM-C210N274

External Room Sensor

MRW-TA

Features

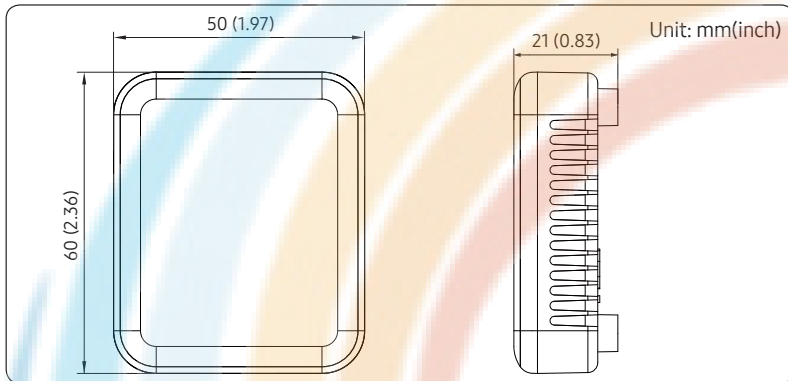

- Indoor unit is operated by MRW-TA instead of its own sensor.
- Wire length : 12m(39ft)

Components

Cable Tie(2)	M4X16 Tapped Screw (2)	12m Extension Wire (1)	External Room Sensor (1)	Adapter (2)	Wire Joint (2)	Seal Thermal Kit (1)	Installation Manual (1)

⚠ Caution

- The external room sensor must be installed by an installation specialist.
- Before installing the external room sensor, check that you have turned off the main power.
- Extension wire should be installed according to the national wiring rules and you must install it to the wall not to be touched by users.

Simulation of usage

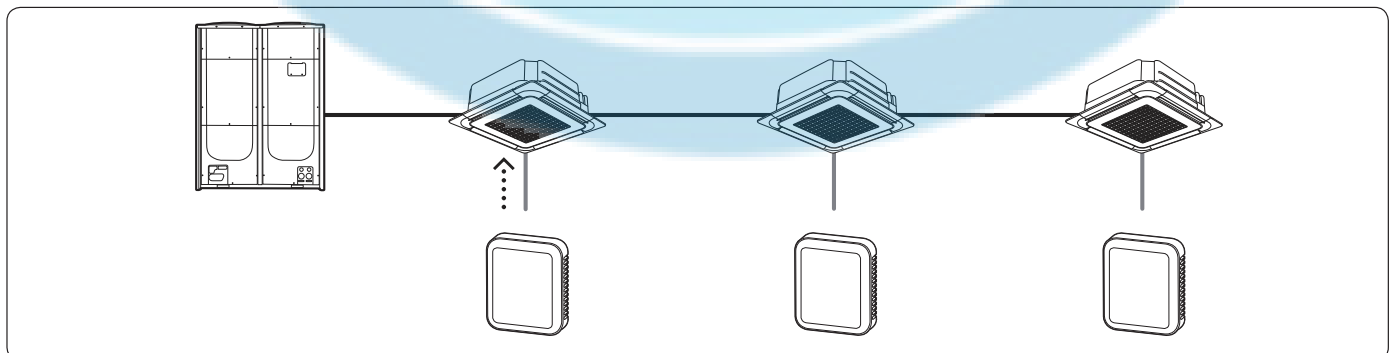

External Room Sensor > MRW-TA

Installation

- Separate the existing thermistor wire from the indoor unit PCB.
- Connect the provided 4P-WIRE adaptor to the thermistor wire(4Pin) terminal on the indoor unit PCB.
- Connect the existing wire to the 4Pin terminal on the 4P-WIRE adaptor.
- Connect the extension wire terminal to the 2Pin terminal on the adaptor.
- Do not cut the existing room temperature sensor and store it inside of the control box.

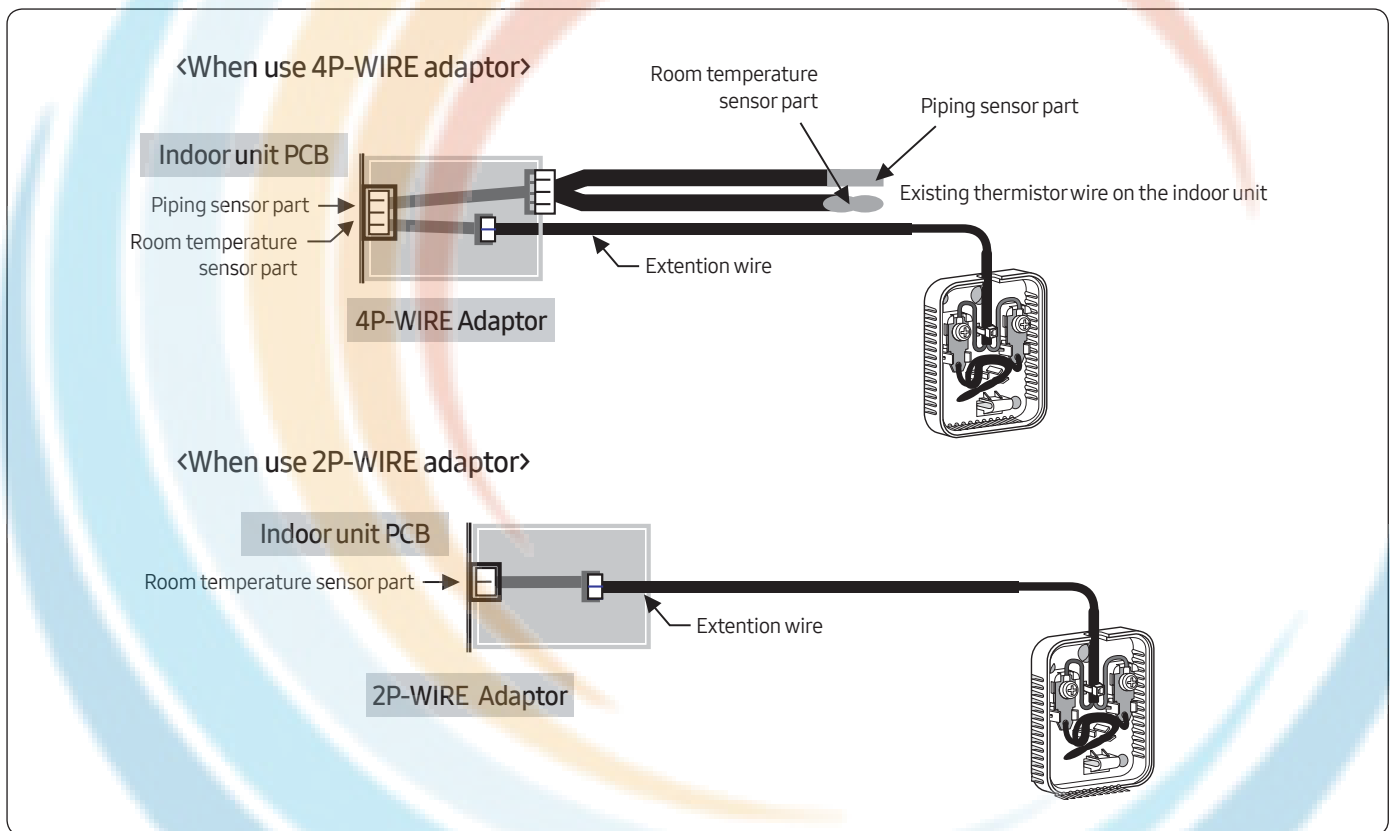

⚠ Caution

- When installing the external room sensor, turn off the K1 switch of indoor unit PCB.
- Some models need S/W upgrade.

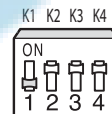

※ Before installation you should read installation manual and check whether it is installed correctly after installation.

Operation mode selection switch

MCM-C200U

Features

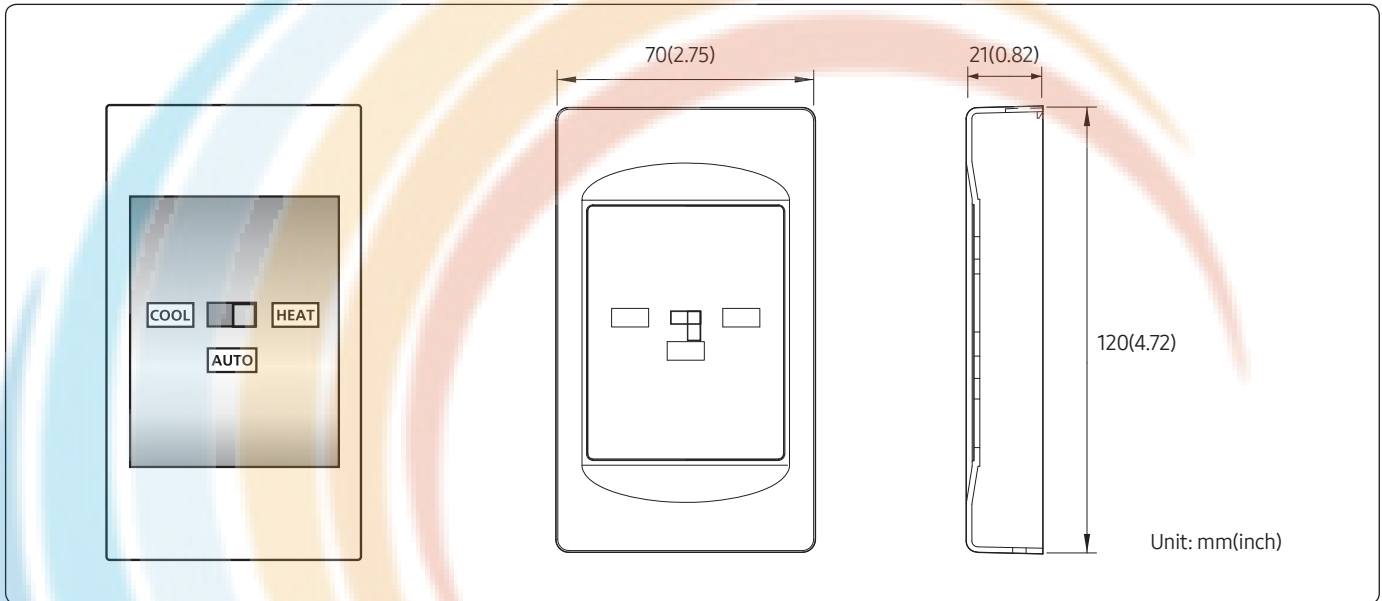

Operation mode selection switch

- Outdoor unit operation mode selection (Cooling, Heating or Auto)
- Mixed operation mode protection

Installation

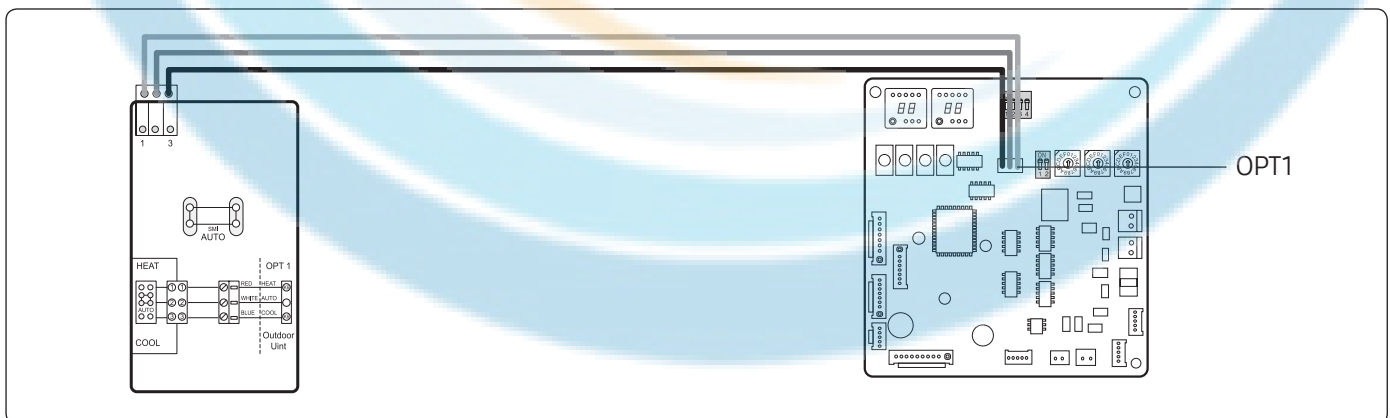

- 1 operation mode selection switch must be connected to 1 outdoor unit.
- Max. distance between the outdoor unit PCB and the MCM-C200: 100m(328ft)

Operation mode selection switch > MCM-C200U

Control example

Initial condition

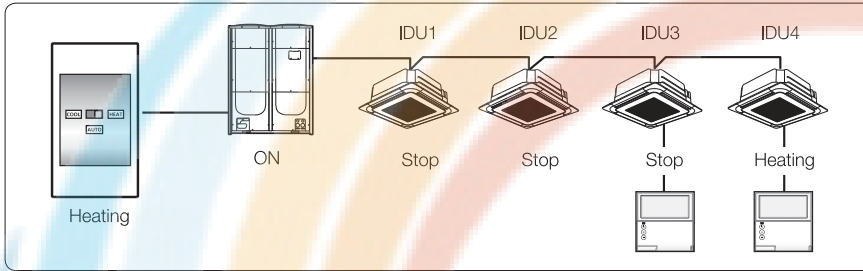

- Cool/Heat Selector: Heating position
- IDU1, 2, 3: Stop mode, IDU4: Heating mode
- Compressor ON

Sequence 1

Set the Cool/Heat selector to the Cooling position

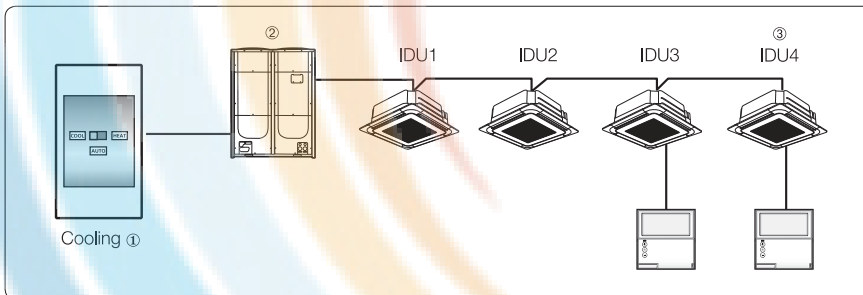

Result

- ① Change Cool/Heat Selector to Cooling
- ② Automatically compressor OFF
- ③ Running IDU4 stops

Sequence 2

Set IDU4 to Heating with Remote controller

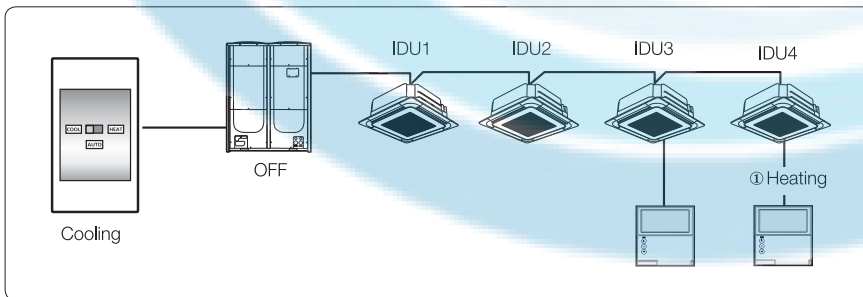

Result

- ① • IDU4 ignores Heating command
- IDU4 keeps OFF status.

Note

- Operation mode selection switch fixed indoor unit operation mode. Indoor unit ignores opposite operation mode. (It will not accept the command and it will just beep shortly)

MTFC (Multi Tenant Function Controller)

MCM-C210N

Features

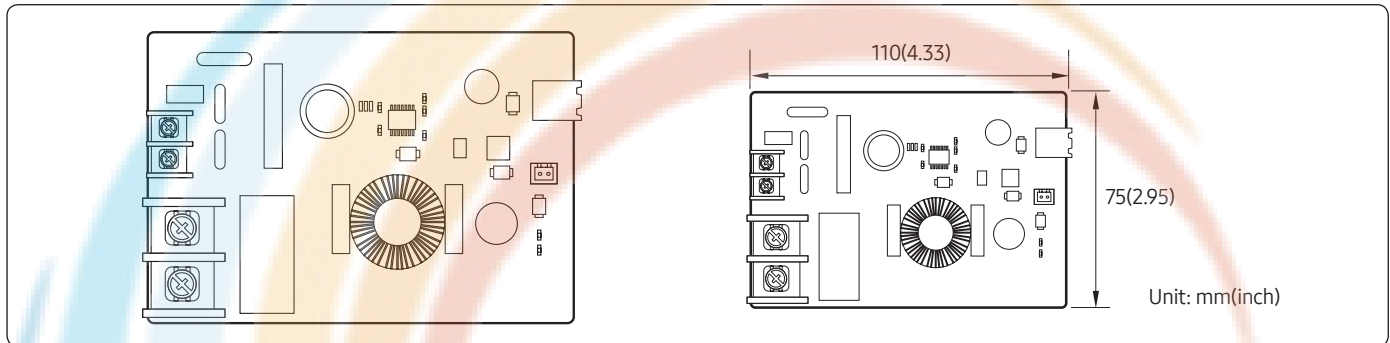

- Multi tenant function controller is an auxiliary power supply device which allows indoor unit to turn off (close EEV) normally and maintain communication when main power supply is cut.
- It is used in site such as hotel where individual power is supplied to the indoor unit

Note

- To install the MTFC, connection cable for the power, transformer and the IP (Ingress Protection) box must be purchased separately at the installation site.
- Specification of the transformer: UL Standard, Class2, 24Vac ±15% 50/60 Hz

Product specification

Power supply	AC 24V
	50/60 Hz
Power consumption	10W
Operating temperature range	-10°C ~ 50°C (14°F ~ 122°F)
Operating humidity range	10 % RH~90 % RH
Maximum length of connection	3 m (9.84)
Number of control devices	1 indoor unit

MTFC (Multi Tenant Function Controller) > MCM-C210N

Description of parts

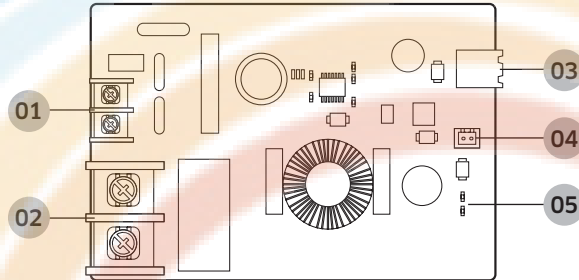

No.	Name	Description
01	Terminal for auxiliary power	Connect AC 24V power
02	Terminal for indoor unit power connection	To check for AC single phase power cut-off of the indoor unit, connect the power cable to the multi tenant function controller.
03	DC 12V output terminal	Terminal which supplies DC 12V to indoor unit
04	DC 5V output terminal	Terminal which supplies DC 5V to indoor unit
05	Operation status indicator LED	<ul style="list-style-type: none"> LED ON: When AC single phase power for indoor unit is cut-off and DC 12V, DC 5V is output normally from the multi tenant function controller LED OFF: When AC single phase is supplied normally to the indoor unit

MTFC (Multi Tenant Function Controller) > MCM-C210N

Connection diagram

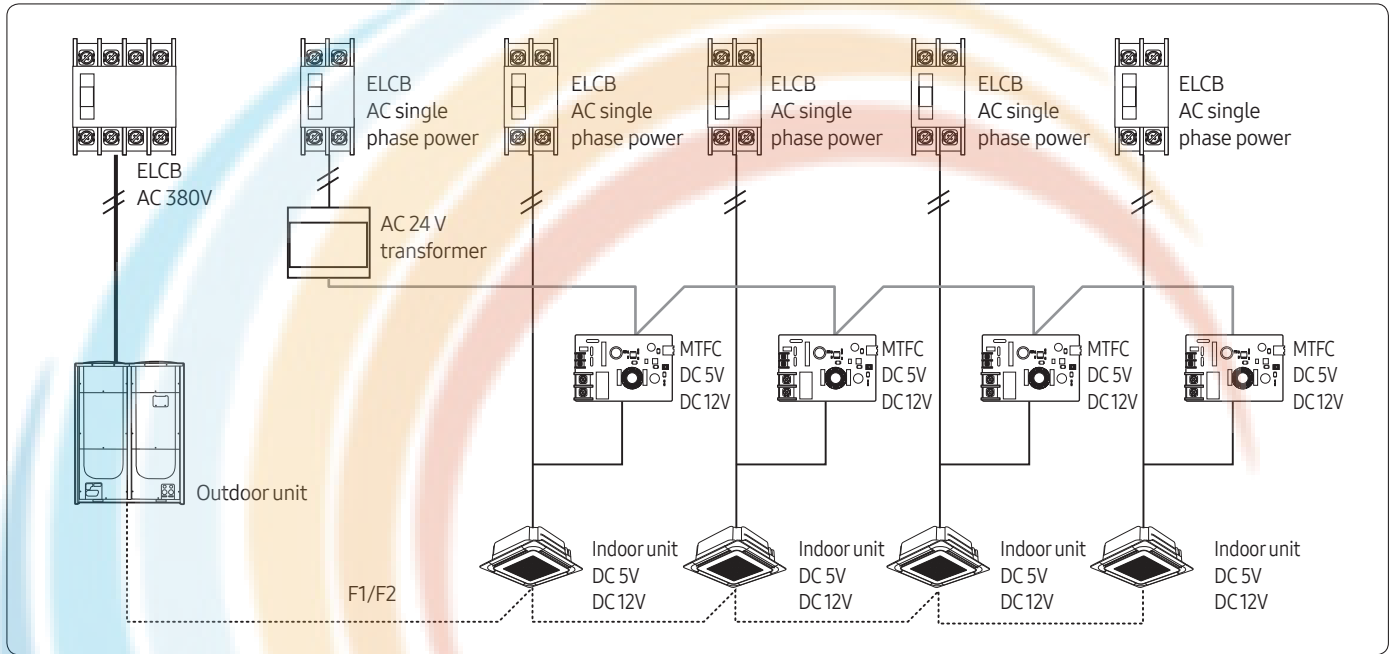

Connecting

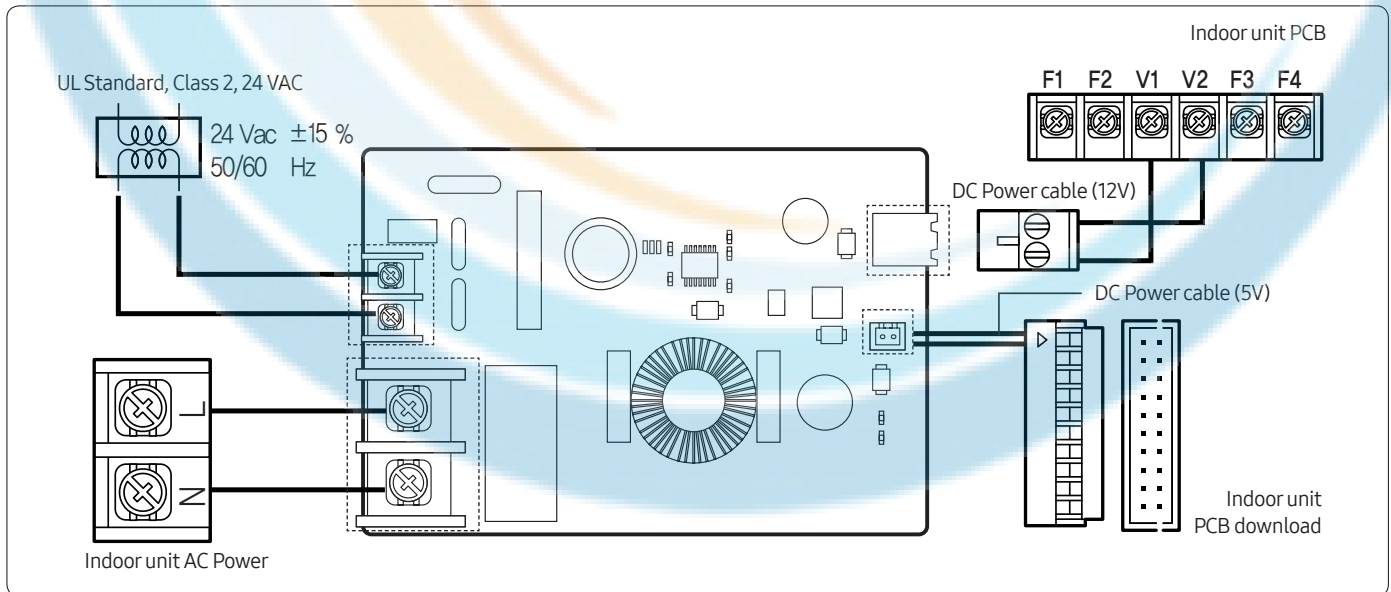

MTFC (Multi Tenant Function Controller) › MCM-C210N

Main function

Multi tenant function controller operation

- When AC power (that is supplied to indoor unit) is cut-off, it supplies auxiliary power (DC 12V, DC 5V) to the indoor unit.
- When AC power (that is supplied to indoor unit) is supplied normally, it cuts-off the auxiliary power (DC 12V, DC 5V) to the indoor unit.

Detail information of the indoor unit when the power is supplied by MTFC

Item	Operation	Detail information
Indoor unit operation	OFF	Remain indoor unit in off status, turning on is not possible
EEV control	Close	Operation off, follows indoor unit's EEV control
Self error diagnosis	Operating	Detects error such as EEV close/open by executing self-diagnosis
Displaying error on panel display	Display partially	Case 1) The errors of itself: it displays. Case 2) The errors of the other units: it doesn't display.
Operation of the connected wired remote controller	OFF	Power cut (not working)
Panel display	All off	All LEDs is off
Input outdoor unit key mode (Test run)	Not operating	The others are operated except the indoor unit in MTFC mode
Controlling from the control device	Not operating	Remain off status, turning on is not possible
Setting option code	Not operating	Option setting from wireless remote controller, wired remote controller and S-NET Pro etc is not possible
Recognition of MTFC status	Possible only through S-NET Pro 2	Using S-NET Pro2, user can check MTFC working status
Beep	Not operating	-

When AC single phase power is normally supplied to indoor unit

Indoor unit operates normally.

⚠ Caution

- Wired remote controller for group control cannot be installed to an indoor unit which Multi Tenant Function controller was installed.
- EEV operation of the stopped Heat mode will be controlled in same condition as noise reduction control option when Multi Tenant Function Controller operates.
- If the Multi Tenant Function Controller operates while multiple indoor units are working in mixed operation mode (cooling and heating at the same time), dew may form on the indoor unit fan.



2019.07
Ver. 2.4

Samsung Electronics Co., LTD.

Head Office (Suwon Korea) 129, Samsung-Ro, Yeongtong-Gu, Suwon City, Gyeonggi-Do, Korea 16677
Website : www.samsung.com, <https://partnerhub.samsung.com> Email : airconditioner@samsung.com
Images and data in this book may subject to change without prior notice.